

# MS4515



- PCB Mounted Pressure Transducers
- Pressure Ranges from 2 to 30inH<sub>2</sub>O
- Amplified Ratiometric Analog Output
- Differential & Gage
- Temperature Compensated
- 3.3V or 5.0 Vdc Supply Voltage



## DESCRIPTION

The MS4515 is a small, ceramic based, PCB mounted pressure transducer from Measurement Specialties. The transducer is built using Measurement Specialties' proprietary UltraStable™ process and the latest CMOS sensor conditioning circuitry to create a low cost, high performance transducer designed to meet the strictest requirements from OEM customers.

The MS4515 is fully calibrated and temperature compensated with a total error band (TEB) of less than 1.0% over the compensated range. The sensor operates from single supply of either 3.3 or 5.0Vdc and requires a single external component for proper operation.

The rugged ceramic transducer is available in side port, top port, and manifold mount versions and can measure gauge or differential pressure from 2 to 30 inH<sub>2</sub>O. The 1/8" barbed pressure ports mate securely with 3/32" ID tubing.

## FEATURES

- inH<sub>2</sub>O Pressure Ranges
- PCB Mountable
- High Level Analog Output
- Barbed Pressure Ports

## APPLICATIONS

- Blocked Filter Detection
- Altitude and Airspeed Measurements
- Medical Instruments
- Fire Suppression System
- Panel Meter

## STANDARD RANGES (IN H<sub>2</sub>O)

Range	Gauge	Differential	Option Availability
2		DS, SS, TP, MM	
4	DS, SS, TP, MM	DS, SS, TP, MM	
5	DS, SS, TP, MM	DS, SS, TP, MM	
10	DS, SS, TP, MM	DS, SS, TP, MM	-F
20	DS, SS, TP, MM	DS, SS, TP, MM	-F
30	DS, SS, TP, MM	DS, SS, TP, MM	-F

See Package Configurations: DS= Dual Side Port, SS= Single Side Port, TP= Top Port, MM= Manifold Mount  
Pin Style "L" is only available SS and MM port types.

# MS4515

## BLOCK DIAGRAM

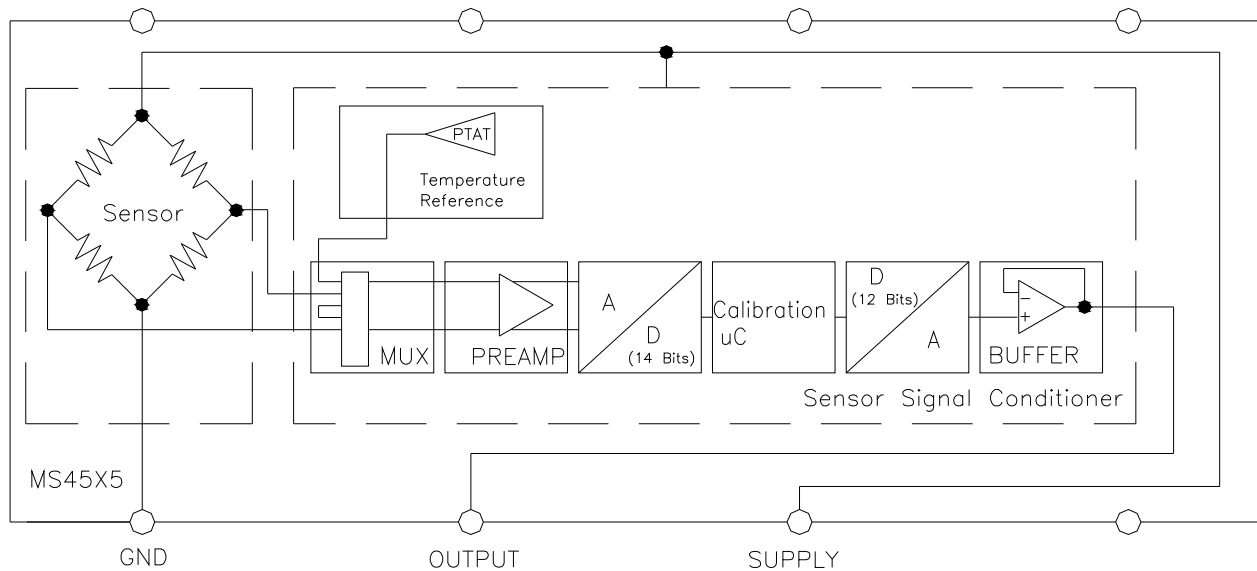

## ABSOLUTE MAXIMUM RATINGS

Parameter	Conditions	Min	Max	Unit	Notes
Supply Voltage	$T_A = 25\text{ }^\circ\text{C}$	2.7	5.5	V	
Output Current	$T_A = 25\text{ }^\circ\text{C}$		3	mA	
Load Resistance ( $R_L$ )	$T_A = 25\text{ }^\circ\text{C}$	10		k $\Omega$	
Storage Temperature		-40	+125	$^\circ\text{C}$	
Humidity	$T_A = 25\text{ }^\circ\text{C}$		95	%RH	Non Condensing
Overpressure	$T_A = 25\text{ }^\circ\text{C}$ , both Ports	Not to Exceed 300		psi	
Burst Pressure	$T_A = 25\text{ }^\circ\text{C}$ , Port 1			psi	See Table 1
ESD	HBM	-4	+4	kV	EN 61000-4-2
Solder Temperature	250 $^\circ\text{C}$ , 5 sec max.				

**TABLE 1- BURST PRESSURE BY RANGE AND PACKAGE STYLE**

Range	DS	TP, SS, MM	Unit
002	10	10	psi
004	10	10	psi
005	10	10	psi
010	10	10	psi
020	20	20	psi
030	20	20	psi

# MS4515

## ENVIRONMENTAL SPECIFICATIONS

Parameter	Conditions
Mechanical Shock	Mil Spec 202F, Method 213B, Condition C, 3 Drops
Mechanical Vibration	Mil Spec 202F, Method 214A, Condition 1E, 1Hr Each Axis
Thermal Shock	100 Cycles over Storage Temperature, 30 minute dwell
Life	1 Million FS Cycles
MTTF	>10Yrs, 70 °C, 10 Million Pressure Cycles, 120%FS Pressure

## PERFORMANCE SPECIFICATIONS

Supply Voltage<sup>1</sup>: 5.0V or 3.3 Vdc

Ambient Temperature: 25°C (unless otherwise specified)

PARAMETERS	MIN	TYP	MAX	UNITS	NOTES
Accuracy	-0.25		0.25	%Span	2
Total Error Band (TEB)	-1.0		1.0	%Span	3,5
Total Error Band (TEB) 4inH <sub>2</sub> O and Below	-2.0		2.0	%Span	3,5
Supply Current		3		mA	5
Compensated Temperature	0		+60	°C	4
Operating Temperature	-10		+85	°C	
Response Time		1		mS	5
Weight		3		grams	
Media	Non-Corrosive Dry Gases Compatible with Ceramic, Silicon, Pyrex, PPS, RTV, Gold, Aluminum and Epoxy. See "Wetted Material by Port Designation" chart below.				

### Notes

1. Proper operation requires an external capacitor placed as shown in Connection Diagram. Output is ratiometric to supply voltage variations of less than 10%.
2. Accuracy: The maximum deviation from a best fit straight line (BFSL) fitted to the output measured over the pressure range at 25°C. Includes all errors due to pressure non linearity, hysteresis, and non repeatability.
3. Total error band includes all accuracy errors, thermal errors over the compensated temperature range, and span and offset calibration tolerances. For ideal sensor output with respect to input pressure, reference Pressure Transfer Function charts below. TEB values are valid only at the calibrated supply voltage.
4. For errors beyond the compensated temperature range, see Extended Temperature Multiplier chart below.
5. This product can be configured for custom OEM requirements, contact factory for lower power consumption or higher accuracy.

# MS4515

## CONNECTION DIAGRAM

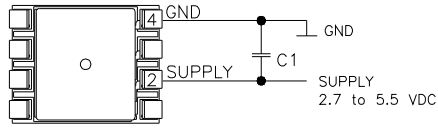

### Notes

- Place 100nF capacitor between Supply and GND to within 2 cm of sensor.

## PRESSURE AND TEMPERATURE TRANSFER FUNCTION

Pressure Transfer Functions, Supply=5V

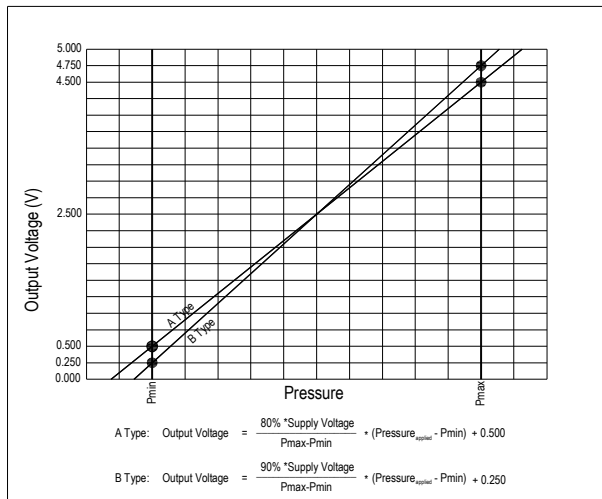

Pressure Transfer Functions, Supply=3.3V

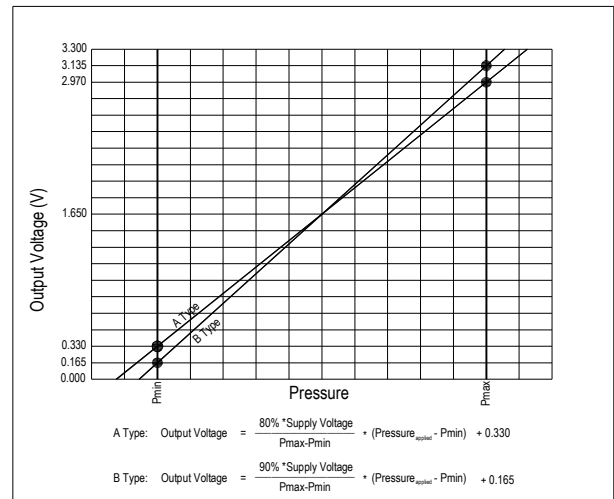

Sensor Output at Significant Percentages (Supply=5.000V)

% Output	Output Type A (inH2O)	Output Type B (inH2O)	Voltage(V)
0	$P_{\text{min}} - (P_{\text{max}} - P_{\text{min}}) * 10 / 80$	$P_{\text{min}} - (P_{\text{max}} - P_{\text{min}}) * 5 / 90$	0.000
5		$P_{\text{min}}$	0.250
10	$P_{\text{min}}$		0.500
50			2.500
90	$P_{\text{max}}$		4.500
95		$P_{\text{max}}$	4.750
100	$P_{\text{max}} + (P_{\text{max}} - P_{\text{min}}) * 10 / 80$	$P_{\text{max}} + (P_{\text{max}} - P_{\text{min}}) * 5 / 90$	5.000

Sensor Output at Significant Percentages (Supply=3.300V)

% Output	Output Type A (inH2O)	Output Type B (inH2O)	Voltage(V)
0	$P_{\text{min}} - (P_{\text{max}} - P_{\text{min}}) * 10 / 80$	$P_{\text{min}} - (P_{\text{max}} - P_{\text{min}}) * 5 / 90$	0.000
5		$P_{\text{min}}$	0.165
10	$P_{\text{min}}$		0.330
50			1.650
90	$P_{\text{max}}$		2.970
95		$P_{\text{max}}$	3.135
100	$P_{\text{max}} + (P_{\text{max}} - P_{\text{min}}) * 10 / 80$	$P_{\text{max}} + (P_{\text{max}} - P_{\text{min}}) * 5 / 90$	3.300

# MS4515

## EXTENDED TEMPERATURE MULTIPLIER CHART

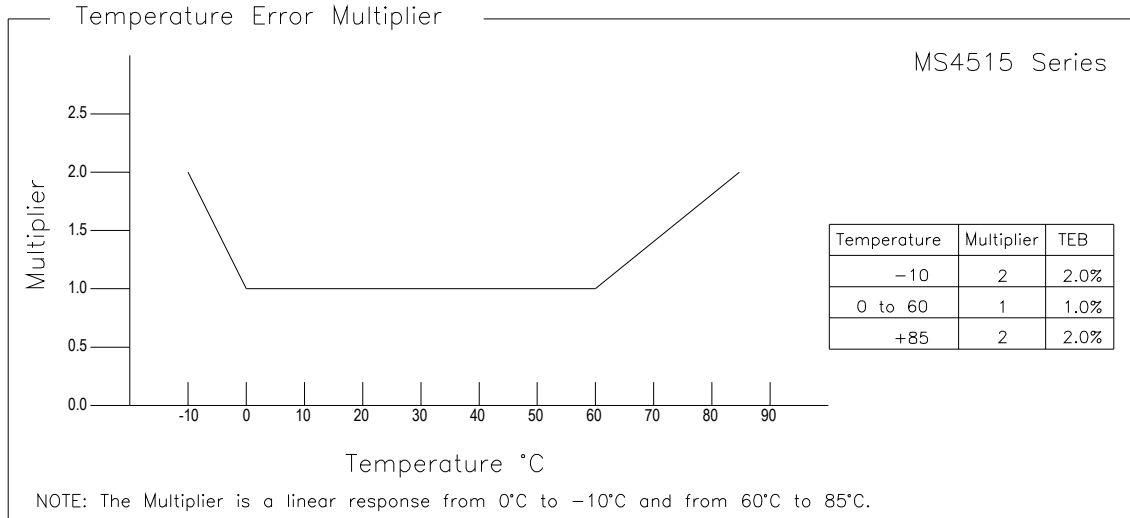

## PACKAGE, PINOUT & PRESSURE TYPE CONFIGURATION

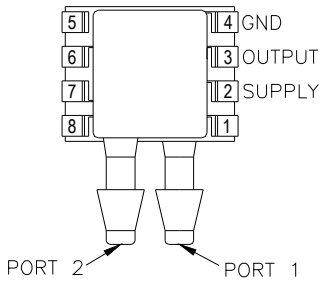

MS4515-DSv0xxxP

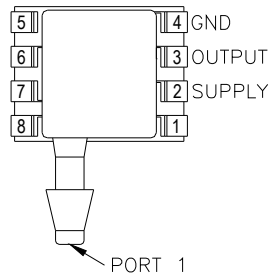

MS4515-SSv0xxxP

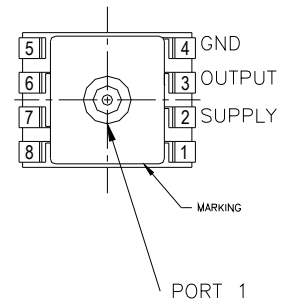

MS4515-TPv0xxxP

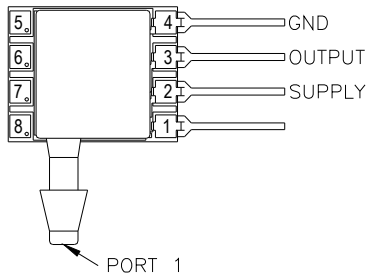

MS4515-SSv0xxxL

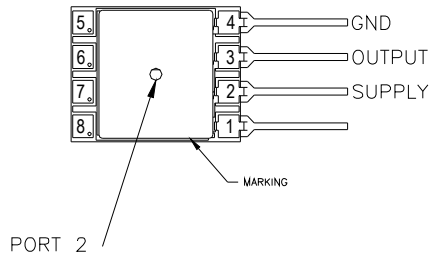

MS4515-MMv0xxxL

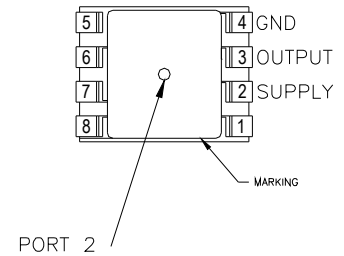

MS4515-MMv0xxxP

# MS4515

Pin Name	Pin	Function
SUPPLY	2	Positive Supply Voltage
OUTPUT	3	Analog Output
GND	4	Ground
	1, 5-8	No Connection

Pressure Type	Pmin	Pmax	Description
Differential/ Bidirectional	-Prange	+Prange	Output is proportional to the difference between Port 1 and Port 2. Output swings positive when Port 1 > Port 2. Output is 50% of supply voltage when Port 1=Port 2
Gauge	0psiG	+Prange	Output is proportional to the difference between 0psiG (Pmin) and Port 1. Output swings positive when Port 1 > Port 2.

Prange is equal to the maximum full scale pressure specified in the ordering information.

## WETTED MATERIAL BY PORT DESIGNATION

Style	Port	Material							
		PPS	Ceramic	Silicon	Pyrex	RTV	Gold	Aluminum	Epoxy
DS, MM	Port 1	X	X	X	X	X			X
	Port 2	X	X	X	X	X	X	X	X
SS, TP	Port 1	X	X	X	X	X	X	X	X

"X" Indicates Wetted Material

# MS4515

## DIMENSIONS

DIMENSIONS ARE IN INCHES [mm]

Model MS4515-DSvoxxxyp

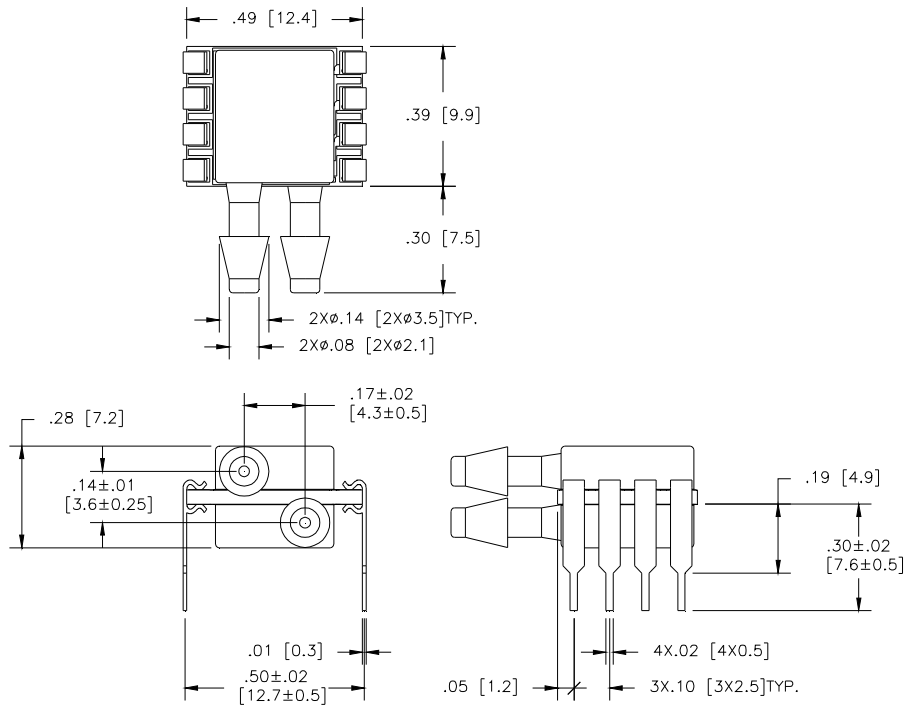

Model MS4515-DSvoxxxys

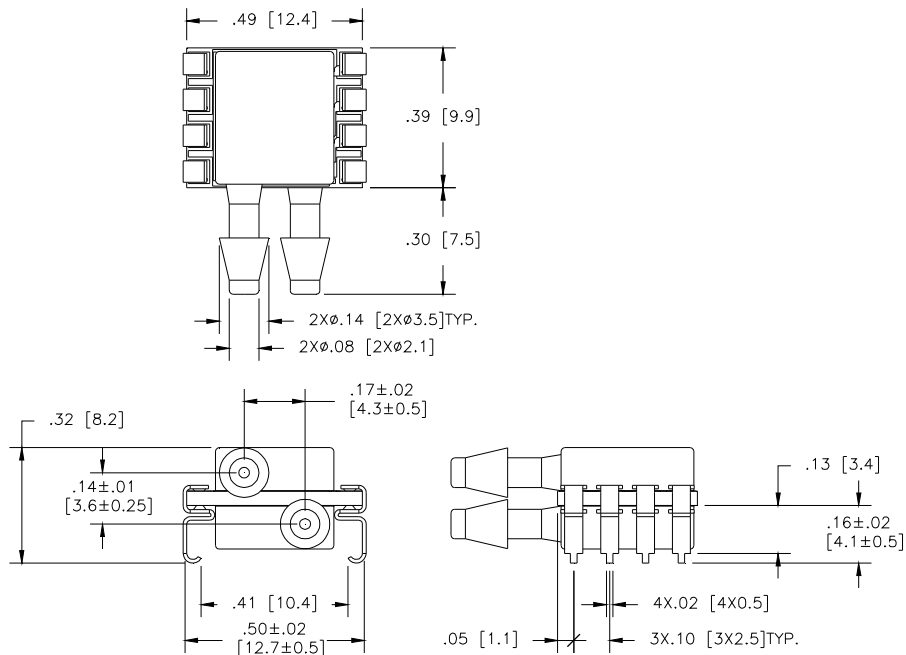

# MS4515

DIMENSIONS ARE IN INCHES [mm]

Model MS4515-SSvoxxxyP

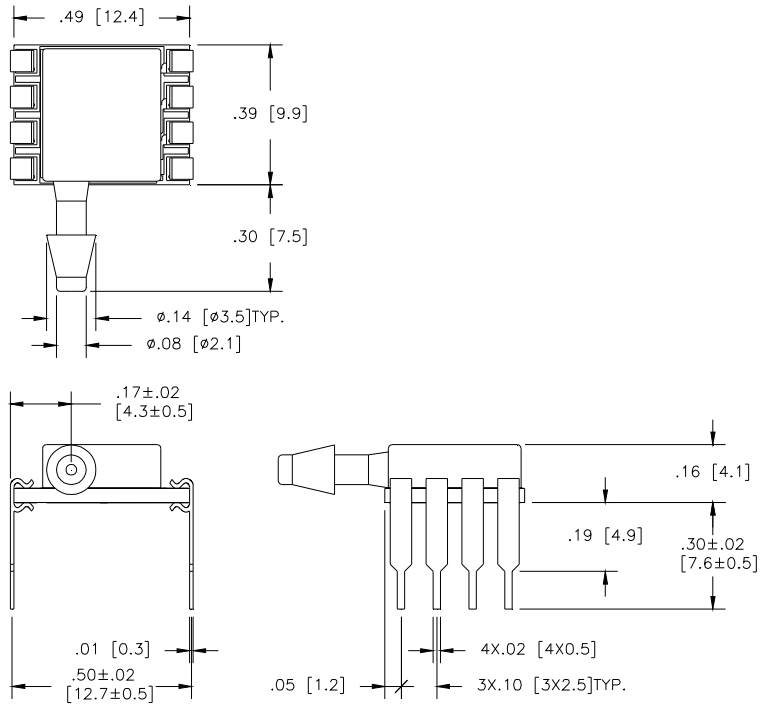

Model MS4515-SSvoxxxyS

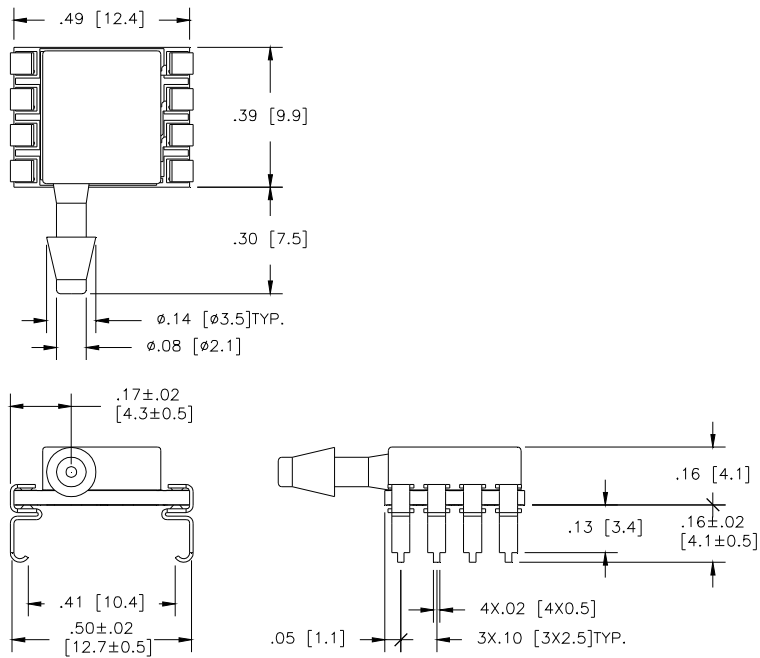

# MS4515

DIMENSIONS ARE IN INCHES [mm]

Model MS4515-TPvxxxxyP

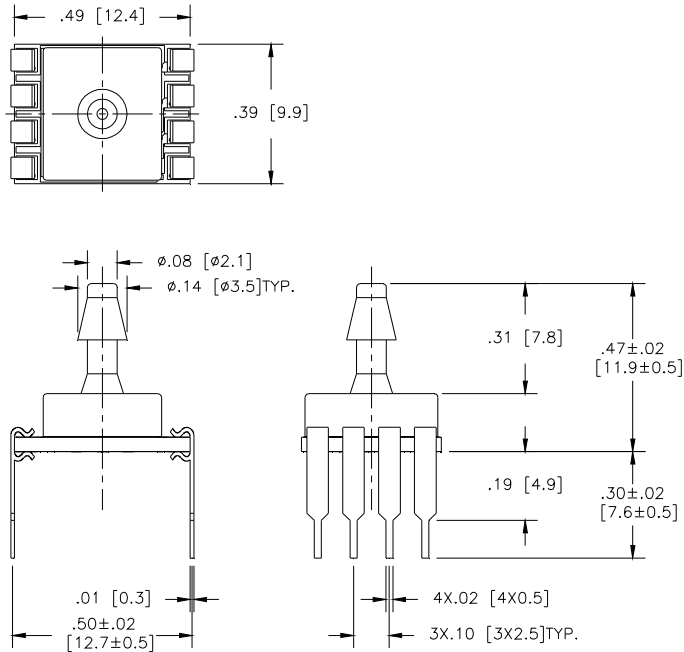

Model MS4515-TPvxxxxyS

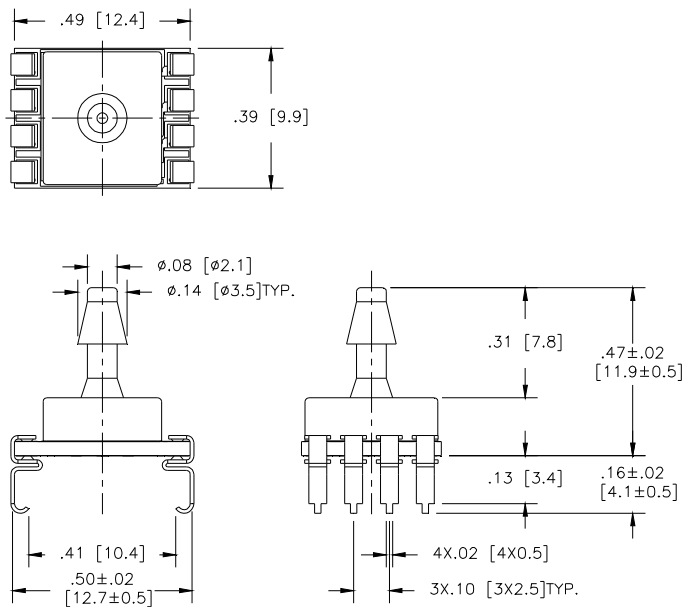



# MS4515

DIMENSIONS ARE IN INCHES [mm]

Model MS4515-MMvxxxxyP

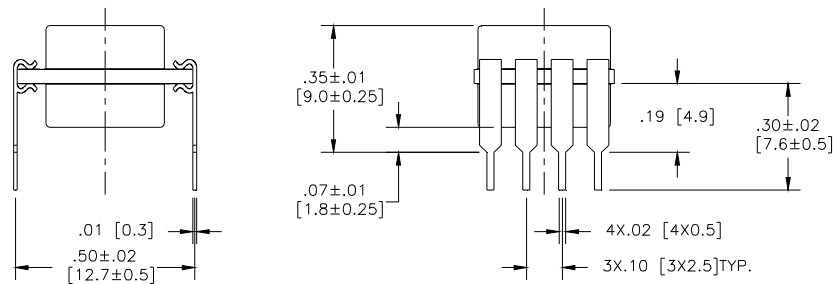
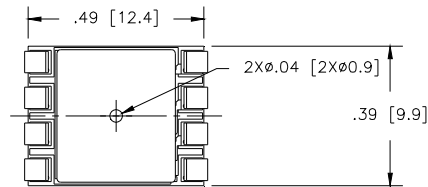

Model MS4515-MMvxxxxyS

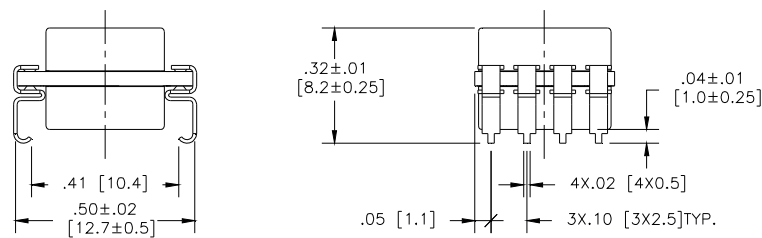
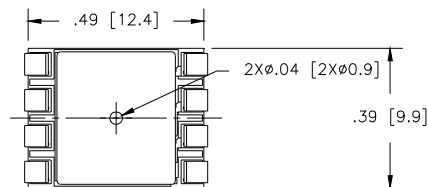

# MS4515

## AVAILABLE OPTIONS

### Gel Coat (-F Option)

The MS45x5 is designed for non ionic and clean dry air applications. Select this option for added protection in high humidity or slightly corrosive environments with the application of a silicone gel elastomer to sensor and ASIC. For questions concerning media compatibility, contact the factory.

## ORDERING INFORMATION

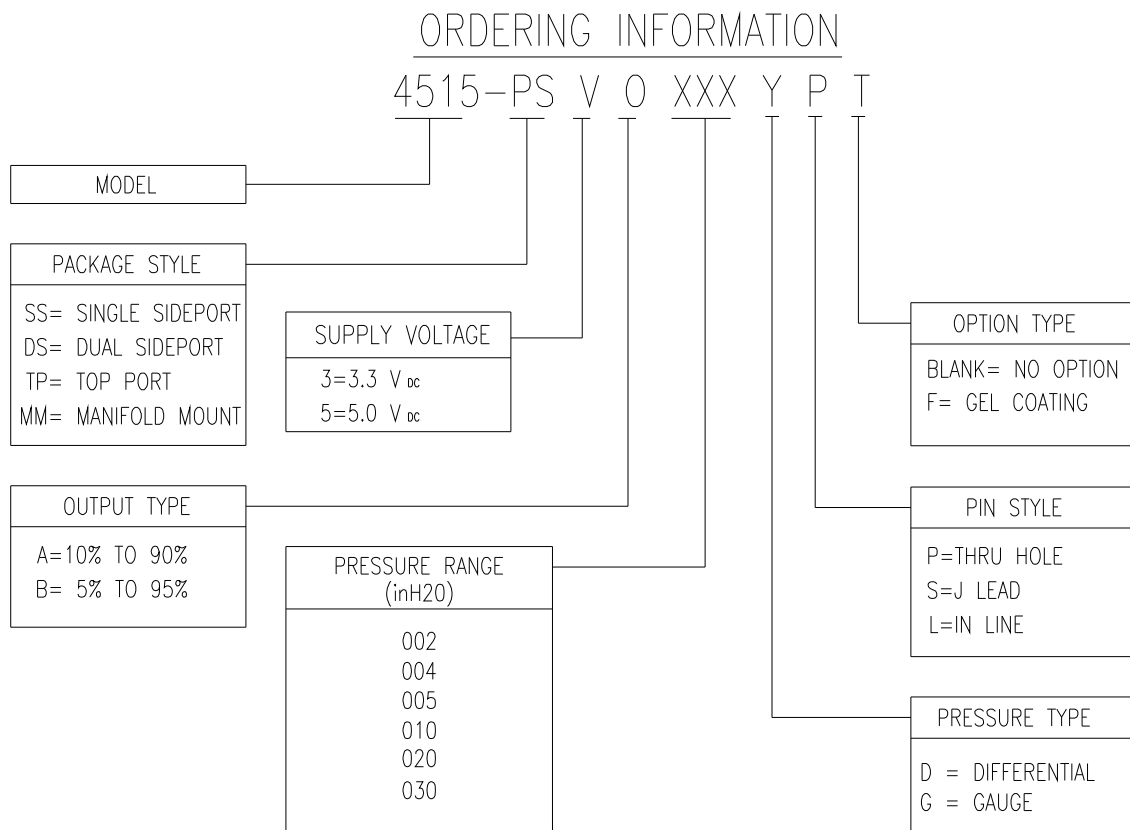

## MS4515

### NORTH AMERICA

Measurement Specialties  
45738 Northport Loop West  
Fremont, CA 94538  
Tel: 1-800-767-1888  
Fax: 1-510-498-1578  
Sales: [pfg.cs.amer@meas-spec.com](mailto:pfg.cs.amer@meas-spec.com)

### EUROPE

Measurement Specialties  
(Europe), Ltd.  
26 Rue des Dames  
78340 Les Clayes-sous-Bois, France  
Tel: +33 (0) 130 79 33 00  
Fax: +33 (0) 134 81 03 59  
Sales: [pfg.cs.emea@meas-spec.com](mailto:pfg.cs.emea@meas-spec.com)

### ASIA

Measurement Specialties  
(China), Ltd.  
No. 26 Langshan Road  
Shenzhen High-Tech Park (North)  
Nanshan District, Shenzhen 518057  
China  
Tel: +86 755 3330 5088  
Fax: +86 755 3330 5099  
Sales: [pfg.cs.asia@meas-spec.com](mailto:pfg.cs.asia@meas-spec.com)

The information in this sheet has been carefully reviewed and is believed to be accurate; however, no responsibility is assumed for inaccuracies. Furthermore, this information does not convey to the purchaser of such devices any license under the patent rights to the manufacturer. Measurement Specialties, Inc. reserves the right to make changes without further notice to any product herein. Measurement Specialties, Inc. makes no warranty, representation or guarantee regarding the suitability of its product for any particular purpose, nor does Measurement Specialties, Inc. assume any liability arising out of the application or use of any product or circuit and specifically disclaims any and all liability, including without limitation consequential or incidental damages. Typical parameters can and do vary in different applications. All operating parameters must be validated for each customer application by customer's technical experts. Measurement Specialties, Inc. does not convey any license under its patent rights nor the rights of others.