

FP110 Flush Diaphragm Pressure Transducer



- Built in stainless steel
- Ranges from 10 to 500 bars [150 to 7500 psi]
- Integrated amplifier version as option
- IP66 protection
- For static and dynamic applications
- Gage



DESCRIPTION

The **FP110** is designed to measure static and dynamic pressure with the output characteristics substantially kept up to about 20% of the resonant frequency. The all stainless steel construction and flush diaphragm allow the sensor to be used under a wide variety of conditions and in temperatures up to 120 °C.

Fitted with metallic strain gauges in a Wheatstone bridge circuit, the **FP110** provides excellent temperature stability. It is available in standard ranges from 0-10 bar to 0-500 bars [0 - 150 to 0 - 7500 psi]. An on-board **A1** or **A2** amplifier for high level output is optionally available. For 200°C high temperature range model FP120-/HT

Consult Measurement-Specialties' Engineering Department if the standard options do not meet your needs or should your application require a more comprehensive measurement system.

FEATURES

- M16 thread
- Wide Temperature Ranges
- Flush Diaphragm
- High Level Tension Output Available
- Accepts wide range of fluids

APPLICATIONS

- Industrial pump discharge
- Corrosive fluid storage
- Onboard equipment monitoring
- Hydraulic regulation process
- Laboratory and research

STANDARD RANGES

Range in bar	10	20	50	100	200	350	500
Range in psi	150	300	750	1 500	3 000	5 000	7 500
Accuracy %F.S.	<±0.3	<±0.3	<±0.3	<±0.3	<±0.5	<±0.5	<±0.5
Over-range	X2	X2	X2	X2	X2	X2	X1.5
Resonance Frequency (kHz)	15	20	27	35	40	45	55

FP110 Flush Diaphragm Pressure Transducer

PERFORMANCE SPECIFICATIONS

All values are typical at temperature 20±1°C

Parameters	
Operating Temperature Range (OTR)	-40 to 80 ° C [-40 to 176 ° F]
Compensated Temperature Range (CTR)	0 to 60 ° C [32 to 140 ° F]
Zero Shift in CTR	<1% F.S./50°C [100°F]
Sensitivity Shift in CTR	<1.5% of reading / 50 °C [100° F]
Range (F.S.)	See standard ranges table
Over-Range	
Without Damage	1.5x to 2x F.S.
Without Destruction	3x F.S.
Accuracy	
Combined Non-Linearity & Hysteresis	±0.3 to ±0.5% F.S. (see table page 1)

Electrical Characteristics

Model	FP110	FP110-A1	FP110-A2
Supply Voltage	10 Vdc	10 to 30 Vdc	±15 Vcc (±12 to ±18 Vdc)
F.S. Output ⁶	12 mV	4 V ±5% F.S.	5 V ±5% F.S.
Zero Offset ⁶	<± 5% F.S.	0.5 V ±5% F.S.	0 V ±5% F.S.
Input Impedance/Consumption	350 Ω	<25 mA	<25 mA
Output Impedance	350 Ω	1 kΩ ⁷	1 kΩ ⁷
Insulation under 50Vdc	≥100 MΩ	≥100 MΩ	≥100 MΩ

Notes

1. Electrical Termination: Shielded cable, 4 wires, standard length 2m[6.6ft]
2. Material: Body and flush diaphragm in stainless steel, laser welded
3. Protection Index: IP66
4. Pressure Port: M16x1.5 threading
5. Self-centered, sealing ring supplied with the sensor.
6. Standard output signal, custom outputs available on request
7. Output impedance standard, available <100Ω on request.
8. CE conformance according to EN 61010-1, EN 50081-1, EN 50082-1

FP110 Flush Diaphragm Pressure Transducer

DIMENSIONS & WIRING SCHEMATIC (IN METRIC AND IMPERIAL)

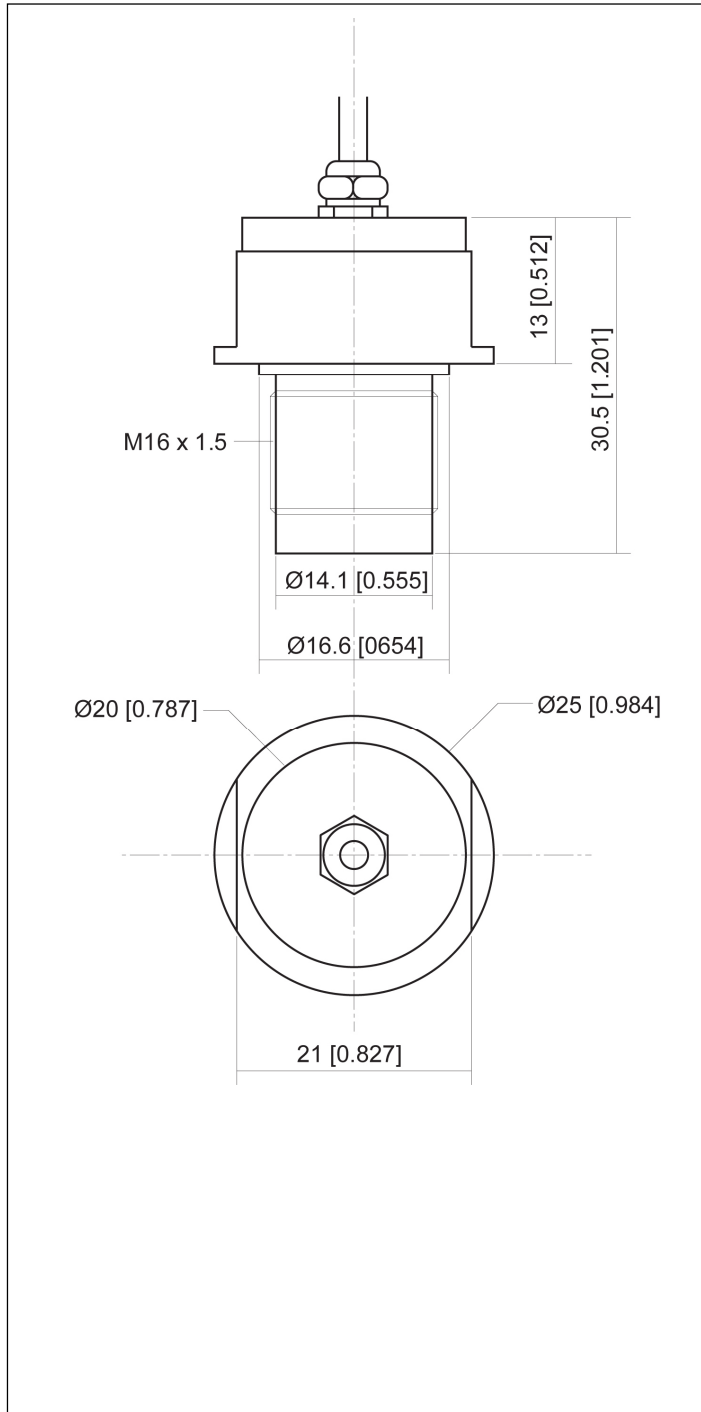

Wiring Schematic

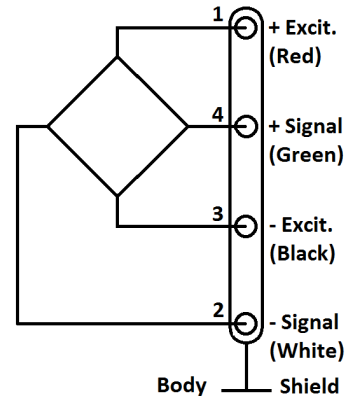

Version -A1

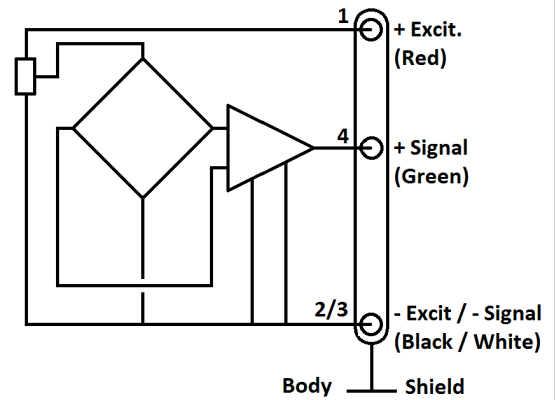

Version -A2

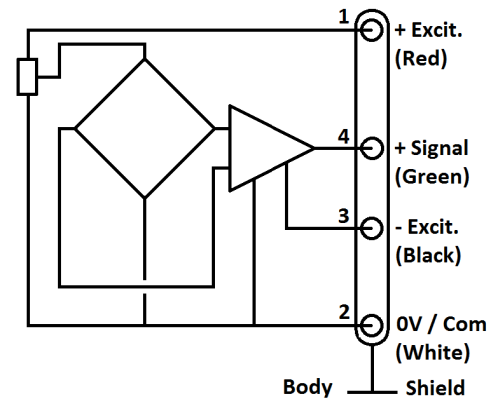

FP110 Flush Diaphragm Pressure Transducer

OPTIONS

A1 : Amplified Tension output with unipolar power supply
A2 : Amplified Tension output with bipolar power supply
ET1 : CTR -20 to 100 °C [-4 to 212°F]
L00M : special cable length, replace "00" with total length in meters

ORDERING INFO

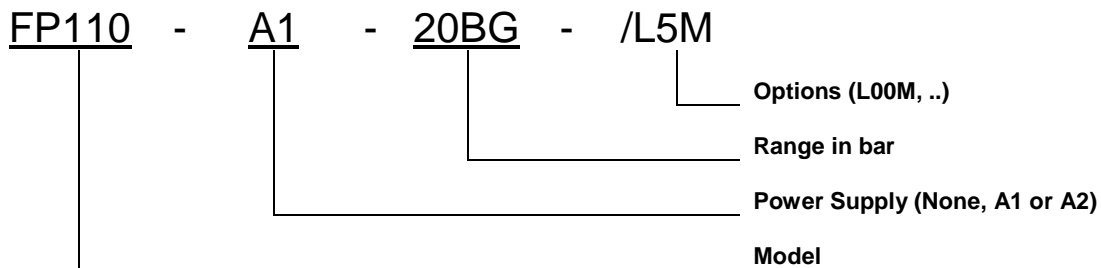

NORTH AMERICA

Measurement Specialties, Inc.
Vibration Design Center
32 Journey - Suite 150
Aliso Viejo, CA 92656
United States USA
Tel: 1-949-716-0877
Fax: 1-949-916-5677
t&m@meas-spec.com

EUROPE

Measurement Specialties
(Europe), Ltd.
26 Rue des Dames
78340 Les Clayes-Sous-Bois,
France
Tel: +33 (0) 130 79 33 00
Fax: +33 (0) 134 81 03 59
cs.lcsb@meas-spec.com

ASIA

Measurement Specialties
(China), Ltd.
No. 26 Langshan Road
Shenzhen High-Tech Park (North)
Nanshan District, Shenzhen
518057
China
Tel: +86 755 3330 5088
Fax: +86 755 3330 5099
pfg.cs.asia@meas-spec.com

The information in this sheet has been carefully reviewed and is believed to be accurate; however, no responsibility is assumed for inaccuracies. Furthermore, this information does not convey to the purchaser of such devices any license under the patent rights to the manufacturer. Measurement Specialties, Inc. reserves the right to make changes without further notice to any product herein. Measurement Specialties, Inc. makes no warranty, representation or guarantee regarding the suitability of its product for any particular purpose, nor does Measurement Specialties, Inc. assume any liability arising out of the application or use of any product or circuit and specifically disclaims any and all liability, including without limitation consequential or incidental damages. Typical parameters can and do vary in different applications. All operating parameters must be validated for each customer application by customer's technical experts. Measurement Specialties, Inc. does not convey any license under its patent rights nor the rights of others.