

Ultimate-Precision Digital LBB



- High precision, 0.1% of reading or 1µm
- EMI and ESD protected (CE certified)
- Spring or air actuated probes
- Robust cast aluminum case (electronics)
- Stackable with T-Connectors for networking
- T-Connector available separately
- USB interface available (with COM libraries)
- Up to 31 devices on USB with external power
- External power supply available

DESCRIPTION

The **Ultimate-Precision Digital LBB** system consists of DLBB digital probes (or gage heads) daisy chained in a network, using T-Connectors (available separately) with DE-9 connectors. Each DLBB includes a highly repeatable analog AC LVDT (Linear Variable Differential Transformer) probe guided with a precision linear ball bearing, mated to an in-line digital I/O signal conditioning module. The circuitry and firmware feature digital calibration and linearity correction of the digital output position signal with extremely high accuracy.

The DLBB probes operate in conjunction with our available USB interface module. Our robust dimensional gaging probes are engineered to provide highly precise and repeatable measurements in various industrial, quality assurance and metrology applications.

The system is based on an RS-485 half duplex, multi-drop network providing plug-and-play functionality. The DLBB probes convert their position signal into digital data which is then transmitted by the RS-485 network using asynchronous transmission (poll/response). The devices support both standard and buffered modes. Our USB 2.0 full speed compliant interface module connects to this network (using a T-Connector) to communicate with and allow data transfer to a computer. When our USB module is plugged into a computer running a WINDOWS® operating system, the Device Manager (in the section "Universal Serial Bus Controllers") of the Computer Management Console displays the name "Meas-Spec Digital LBB Serial Converter", clearly identifying our DLBB device amongst others.

The available DLBB external power supply is capable of supplying 31 DLBB gaging probes (2 Amps). It features an integral T-Connector which is permanently attached to it. This special T-Connector will interrupt the bus power and switch it over to the external power supply, for all Digital LBB gaging probes connected downstream.

The data sheet for our Ultra-Precision LBB (Linear Ball Bearing) AC gage probes can be found at: http://www.meas-spec.com/product/Position/Digital_LBB.aspx

Measurement Specialties, Inc. (NASDAQ MEAS) offers a full range of position sensors, signal conditioners, as well as many other types of sensors. Data sheets can be downloaded from our web site at: <http://www.meas-spec.com/datasheets.aspx>

*Measurement Specialties acquired Schaevitz Sensors and the **Schaevitz™** trademark in 2000*

Windows® is a registered trademark of Microsoft Corporation

Ultimate-Precision Digital LBB

FEATURES

APPLICATIONS

<ul style="list-style-type: none"> • High resolution 14-bit digitizing module • Built-in digital linearity correction • Robust probes with precision linear ball bearing • Very easy to setup and use, plug-and-play • USB bus or externally powered (both available) • USB device name for easy WINDOWS® recognition • Up to 31 probes on one network (external power) • RoHS compliant and CE certified 	<ul style="list-style-type: none"> • Wobble/run-out of rotating parts (i.e. rotors, axles) • Free-form measurements (i.e. airfoils, windshields, crankshafts, camshafts) • Factory automated inspection systems (i.e. engine pistons, bearings, etc.) • Optics Inspection Systems (i.e. mirrors, lenses) • SPC data collection • Metrology
---	--

SPECIFICATIONS

Parameter	Specification	Comment
Measurement ranges	1, 2, 5, and 10 mm	
Accuracy	0.1% of reading or 1µm	Whichever is greater
Repeatability	0.0065% of range or 0.15µm	Whichever is greater
Calibration temperature	72 ± 7°F [22 ± 4°C]	
Resolution	14 bits	
Supply voltage	5.00 ± 0.25 Volts DC	
Supply current	60mA maximum	
Operating temperature	32 to 140°F [0 to 60°C]	
Storage temperature	-4 to +158°F [-20 to +70°C]	Dry air environment
Maximum operating relative humidity	60%	Non-condensing
Standard and Buffered mode sampling rate	240 readings per second	
Buffer size	3000 Samples	
Bus format	8 Bits, 1 Stop, Odd Parity	
Bus baud rate	187.5KBd	Standard & buffered modes
Bus protocol	Proprietary device addressable	
Bus interface	RS-485	
Max number of DLBB probes on USB	4 (on computer USB bus power) 31 (on external power)	Plus USB interface module USB powered by computer USB
Cable length	2 meters	
Cable jacket material	Polyurethane	
Housing material, electronics	Aluminum, epoxy powder coated	
Weight (device without T-Connector)	115 grams	
Weight of T-Connector	50 grams	Available separately
Weight of USB interface	115 grams	Available separately
External power supply output current	2 Amps	Available separately

Ultimate-Precision™ Digital LBB

DRAWINGS AND DIMENSIONS

DIGITAL LBB GAGING PROBE

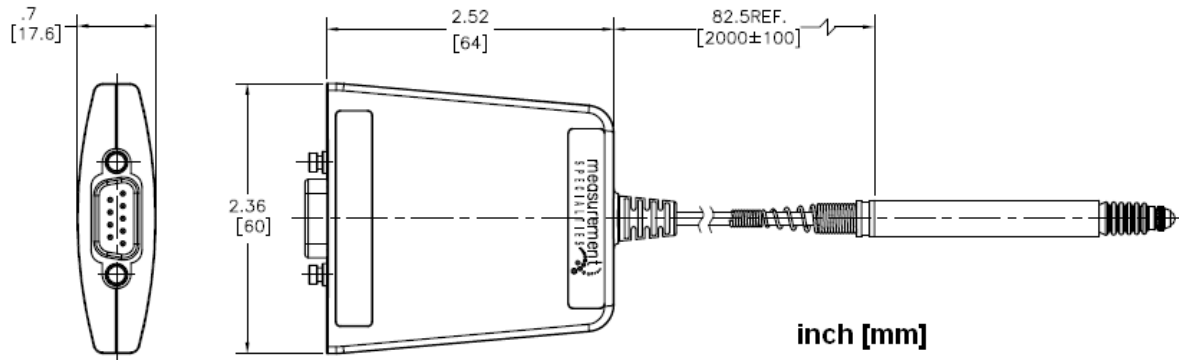

T-CONNECTOR

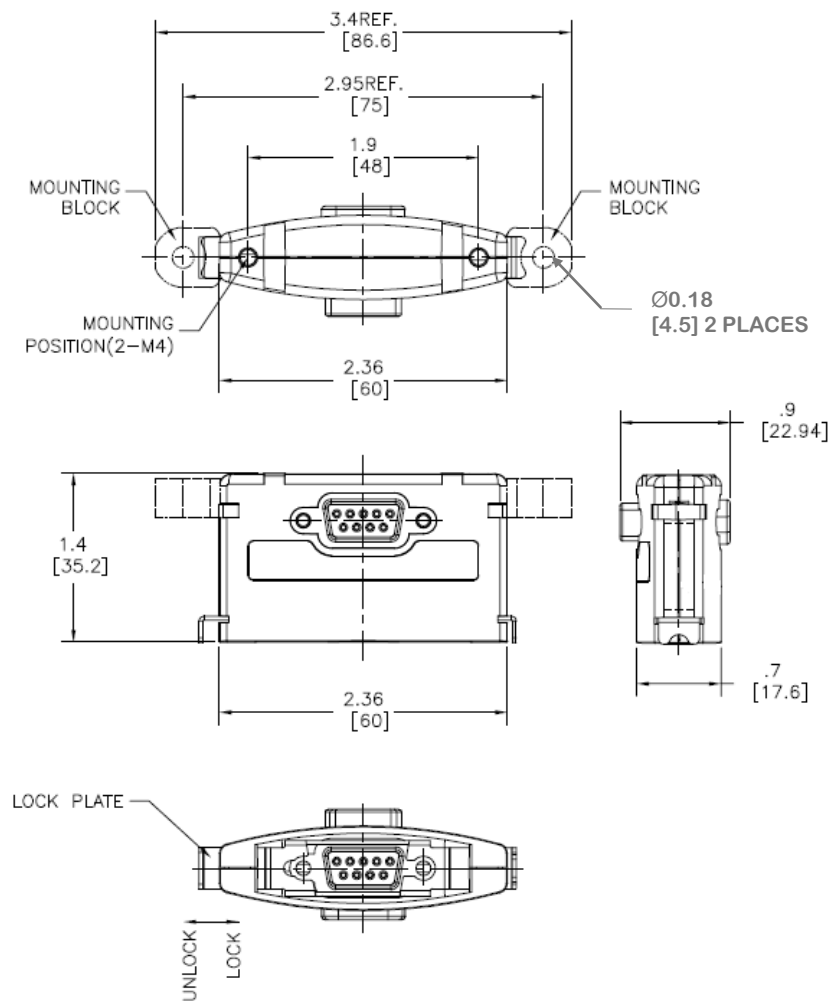

Ultimate-Precision™ Digital LBB

POWER SUPPLY KIT (3 COMPONENTS)

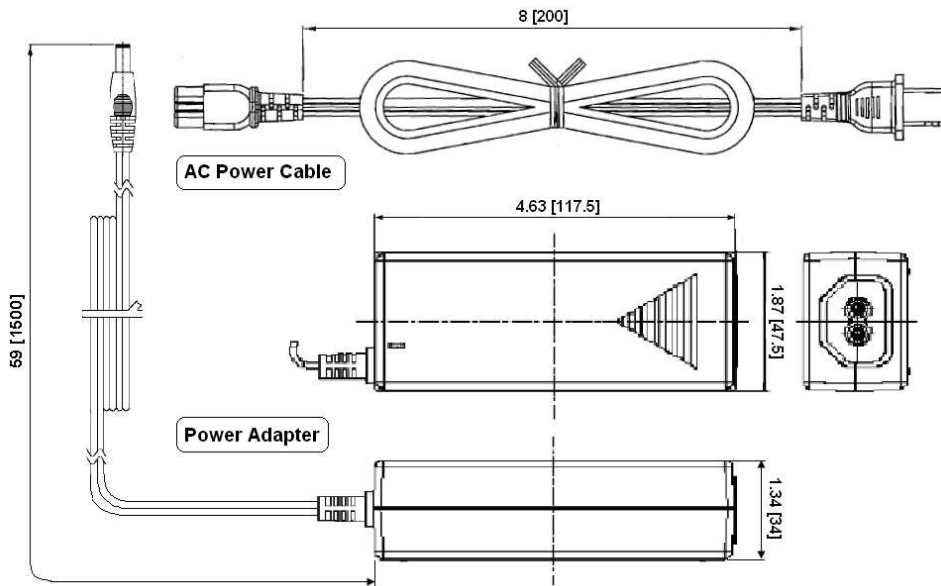
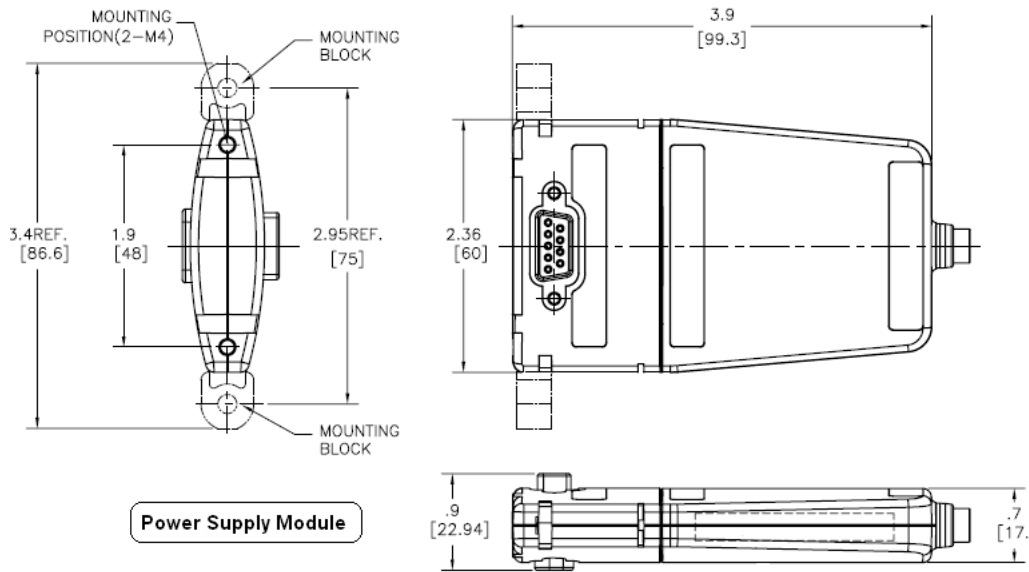

USB INTERFACE MODULE

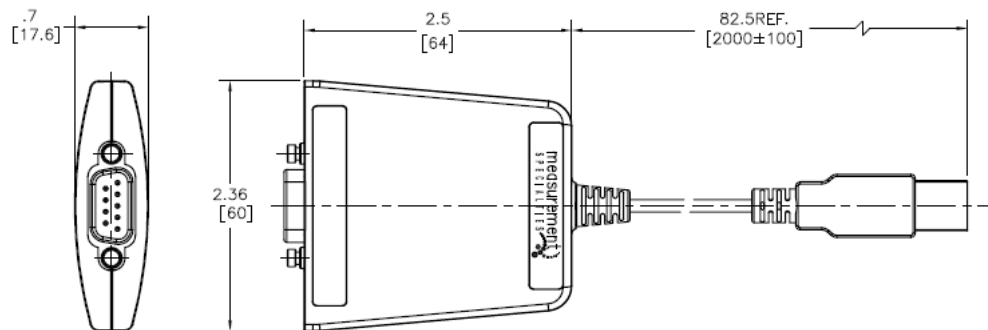

Ultimate-Precision™ Digital LBB

ORDERING INFORMATION

Description	Probe or sleeve dia.	Actuation	Model	Part Number
1mm range probe	8mm	Spring	DLBB315PA-020	72350009-000
2mm range probe	8mm	Spring	DLBB315PA-040	72350012-000
2mm range probe	8mm	Air	DLBB315PA-040A	72350024-000
5mm range probe	8mm	Spring	DLBB315PA-100	72350015-000
5mm range probe	8mm	Air	DLBB315PA-100A	72350021-000
10mm range probe	8mm	Spring	DLBB315PA-200	72350018-000
USB interface module for DLBB			DLBB USB INTERFACE	72290002-000
T-Connector for DLBB			DLBB T-CON	72290003-000
Power supply kit for DLBB (100-240VAC, 50/60Hz input; 5VDC, 2A out)			DLBB USB POWER SUPPLY	72290004-000

Notes:

- Air actuated probes are air-extend, spring-retract
- Sleeves are used to increase the probe housing diameter or to provide bulkhead mounting threads. They can be bonded on top of the probe housings using epoxy

TECHNICAL CONTACT INFORMATION

NORTH AMERICA	EUROPE	ASIA
Measurement Specialties, Inc. 1000 Lucas Way Hampton, VA 23666 United States Phone: +1-800-745-8008 Fax: +1-757-766-4297 Email: sales@meas-spec.com Web: www.meas-spec.com	MEAS Deutschland GmbH Hauert 13 D-44227 Dortmund Germany Phone: +49-(0)231-9740-0 Fax: +49-(0)231-9740-20 Email: info.de@meas-spec.com Web: www.meas-spec.com	Measurement Specialties China Ltd. No. 26, Langshan Road High-tech Park (North) Nanshan District, Shenzhen 518057 China Phone: +86-755-33305088 Fax: +86-755-33305099 Email: info.cn@meas-spec.com Web: www.meas-spec.com

The information in this sheet has been carefully reviewed and is believed to be accurate; however, no responsibility is assumed for inaccuracies. Furthermore, this information does not convey to the purchaser of such devices any license under the patent rights to the manufacturer. Measurement Specialties, Inc. reserves the right to make changes without further notice to any product herein. Measurement Specialties, Inc. makes no warranty, representation or guarantee regarding the suitability of its product for any particular purpose, nor does Measurement Specialties, Inc. assume any liability arising out of the application or use of any product or circuit and specifically disclaims any and all liability, including without limitation consequential or incidental damages. Typical parameters can and do vary in different applications. All operating parameters must be validated for each customer application by customer's technical experts. Measurement Specialties, Inc. does not convey any license under its patent rights nor the rights of others.