

MP Series – Flange Mount AC LVDT



- Operation in harsh environments
- Mounting flanges for easy installation
- Stroke ranges from ± 0.5 to ± 10 inches
- AC operation from 400Hz to 5kHz
- Anodized aluminum housing
- Screw terminal wiring
- PTFE bore liner
- Imperial or metric threaded core

DESCRIPTION

The **MP Series** LVDTs provide classic precision performance in harsh industrial environments. The rugged, extruded anodized aluminum housing contains a 100% epoxy encapsulated LVDT, affording superior environmental, mechanical and EMI/RFI protection. The convenient heavy-duty terminal strip replaces multiple lead wires thereby simplifying electrical connection, while the mounting flanges ease mechanical installation. An integral PTFE bore liner provides a smooth, low-friction bearing surface for the core and reduces diametrical clearance.

Available in a variety of stroke ranges from ± 0.5 to ± 10 inches, the MP Series is the ideal choice for industrial mill type applications, power turbines, or wherever aggressive environmental conditions are present. The MP Series is also available with a small diameter/low-mass core, for applications where excessive core weight could influence the motion. The lightweight core can also reduce mechanical stresses and help preserve the structural integrity of the core actuation assembly during high speed displacement or under high vibration. The MP Series is compatible with the full line of Measurement Specialties LVDT signal conditioners, readouts and controllers.

Like in most of our LVDTs, the MP windings are vacuum impregnated with a specially formulated, high temperature, flexible resin, and the coil assembly is potted inside its housing with a two-component epoxy. This provides excellent protection against hostile environments such as high humidity, vibration and shock.

Measurement Specialties, Inc. (NASDAQ MEAS) offers many other types of sensors and signal conditioners. Data sheets can be downloaded from our web site at: <http://www.meas-spec.com/datasheets.aspx>

MEAS acquired Schaevitz Sensors and the **Schaevitz™** trademark in 2000.

FEATURES

- Rugged aluminum housing
- 100% epoxy encapsulated
- $\pm 0.25\%$ linearity (100% stroke)
- Shock and vibration tolerant
- Screw terminals and mounting flanges
- Calibration certificate supplied with each unit

APPLICATIONS

- Paper mills
- Power turbine valve position
- Rolling mills
- Metal forming presses
- Steel mill “ton-dish” slide valve feedback
- Progressive rotary press Z-axis feedback

MP Series – Flange Mount AC LVDT

PERFORMANCE SPECIFICATIONS

ELECTRICAL SPECIFICATIONS							
Parameter	MP 500	MP 1000	MP 2000	MP 3000	MP 4000	MP 5000	MP 10000
Stroke range	±0.5 [±12.7]	±1 [±25.4]	±2 [±50.8]	±3 [±76.2]	±4 [±101.6]	±5 [±127]	±10 [±254]
Sensitivity, V/V/inch [mV/V/mm]	0.7 [27.6]	0.39 [15.4]	0.23 [9.1]	0.25 [9.8]	0.20 [7.9]	0.14 [5.5]	0.07 [2.8]
Output at stroke ends, mV/V (*)	350	390	460	750	800	700	700
Phase shift	-1°	-3°	-5°	+11°	+1°	+3°	-5°
Input impedance (PRIMARY)	460Ω	460Ω	330Ω	315Ω	275Ω	310Ω	550Ω
Output impedance (SECONDARY)	375Ω	320Ω	300Ω	830Ω	400Ω	400Ω	750Ω
Non-linearity	% of FR						
@ 50% stroke	0.15	0.15	0.15	0.15	0.15	0.15	0.15
@100% stroke (maximum)	0.25	0.25	0.25	0.25	0.25	0.25	0.25
@125% stroke	0.35	1.00	0.50 (**)	0.50 (**)	0.50 (**)	1.00 (**)	1.00 (**)
@150% stroke	0.75	1.30 (**)	1.00 (**)	1.00 (**)	1.00 (**)	/	/
Input voltage	3 VRMS sine wave						
Input frequency	400Hz to 5kHz						
Test frequency	2.5kHz						
Null voltage (max)	0.5% of FRO						

ENVIRONMENTAL SPECIFICATIONS & MATERIALS	
Operating temperature	-65°F to +300°F [-55°C to 150°C]
Shock survival	1,000 g (11ms half-sine)
Vibration tolerance	20 g up to 2kHz
Housing material	Aluminum, anodized
Electrical connection	Six terminal barrier strip

Notes:

All values are nominal unless otherwise noted

Electrical specifications are for the test frequency indicated in the table

Dimensions are in inch [mm] unless otherwise noted

FR: Full Range is the stroke range, end to end; FR=2xS for ±S stroke range

FRO (Full Range Output): difference in outputs measured at the ends of the range

(*) Unit for output at stroke ends is millivolt per volt of excitation (input voltage)

(**) Requires special reduced core length

MP Series – Flange Mount AC LVDT

MECHANICAL SPECIFICATIONS

Parameter	MP 500	MP 1000	MP 2000	MP 3000	MP 4000	MP 5000	MP 10000
Body length "A"	6.50 [165.1]	7.64 [194.1]	11.01 [279.7]	13.85 [351.8]	16.68 [423.7]	18.92 [480.6]	31.90 [810.3]
Core length "B"	3.45 [87.6]	4.00 [101.6]	5.30 [134.6]	5.60 [142.2]	7.00 [177.8]	7.00 [177.8]	8.50 [215.9]
Body weight, oz [g]	12.36 [350]	16.59 [470]	21.00 [595]	26.12 [740]	31.77 [901]	36.18 [1026]	60.89 [1726]
Core weight, oz [g]	0.64 [18]	0.74 [21]	0.95 [27]	0.99 [28]	1.27 [36]	1.27 [36]	1.52 [43]

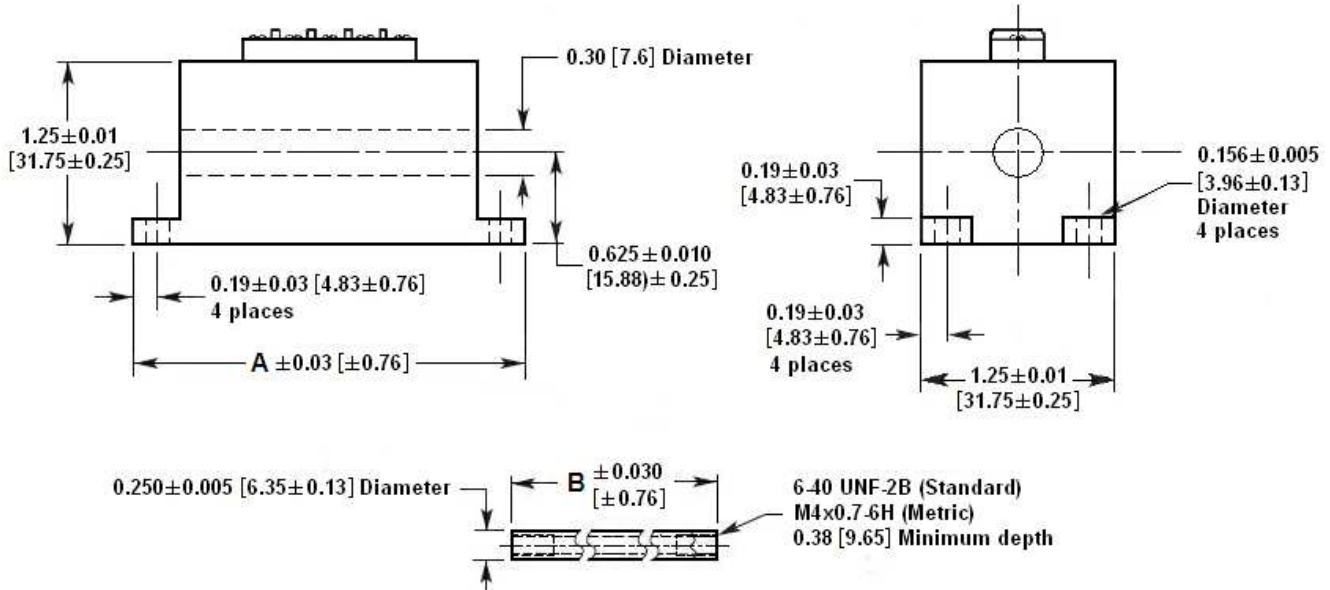

Dimensions are in inch [mm]

WIRING INFORMATION

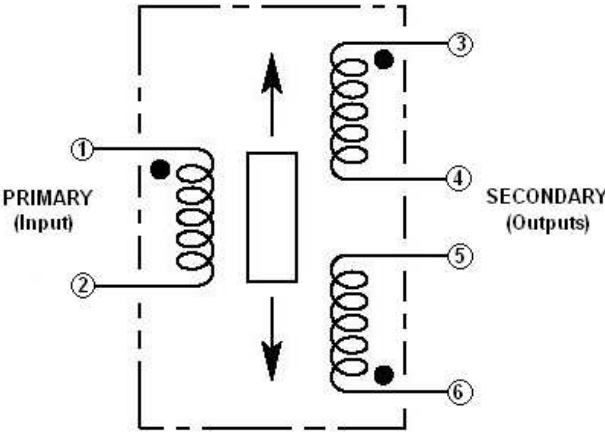

Connect 4 to 5 for differential output

MP Series – Flange Mount AC LVDT

ORDERING INFORMATION

Description	Model	Part Number	Description	Model	Part Number
±0.5 inch LVDT	MP 500	02560498-000	±4 inch LVDT	MP 4000	03560390-000
±1 inch LVDT	MP 1000	02560499-000	±5 inch LVDT	MP 5000	02560502-000
±2 inch LVDT	MP 2000	02560500-000	±10 inch LVDT	MP 10000	02560503-000
±3 inch LVDT	MP 3000	02560501-000			
OPTIONS					
5.0 KHz calibration (<i>Available on MP 500 only</i>)					02560498-002
Metric threaded core (M4 x 0.7)					XXXXXXXX-006
Small-diameter/low-mass core (<i>consult factory for mass and dimensions</i>)					XXXXXXXX-020

Note: Add multiple option dash numbers together to determine proper ordering suffix
 Example: MP 1000, ±1.0 inch, with 5 KHz calibration and metric core, P/N 02560499-008

ACCESSORIES	
Core connecting rod, 6 inches long, 6-40 threads	05282947-006
Core connecting rod, 12 inches long, 6-40 threads	05282947-012
Core connecting rod, 24 inches long, 6-40 threads	05282947-024
Core connecting rod, 36 inches long, 6-40 threads	05282947-036
Core connecting rod, 6 inches long, M4x0.7 metric threads	05282978-006
Core connecting rod, 12 inches long, M4x0.7 metric threads	05282978-012
Interconnect cable for IEM-422 signal conditioner, stripped & tinned to PTO6A-10-6P connector (1)	04290594-000

(1) Cables are shielded, 10 foot long, and are rated 80 °C [176 °F] operating. Consult factory for other lengths.

Refer to our "[Accessories for LVDTs](#)" data sheet for our LVDT signal conditioning instrumentation and other accessories.

TECHNICAL CONTACT INFORMATION

NORTH AMERICA	EUROPE	ASIA
Measurement Specialties, Inc. 1000 Lucas Way Hampton, VA 23666 United States Phone: +1-800-745-8008 Fax: +1-757-766-4297 Email: sales@meas-spec.com Web: www.meas-spec.com	MEAS Deutschland GmbH Hauert 13 D-44227 Dortmund Germany Phone: +49-(0)231-9740-0 Fax: +49-(0)231-9740-20 Email: info.de@meas-spec.com Web: www.meas-spec.com	Measurement Specialties China Ltd. No. 26, Langshan Road High-tech Park (North) Nanshan District, Shenzhen 518057 China Phone: +86-755-33305088 Fax: +86-755-33305099 Email: info.cn@meas-spec.com Web: www.meas-spec.com

The information in this sheet has been carefully reviewed and is believed to be accurate; however, no responsibility is assumed for inaccuracies. Furthermore, this information does not convey to the purchaser of such devices any license under the patent rights to the manufacturer. Measurement Specialties, Inc. reserves the right to make changes without further notice to any product herein. Measurement Specialties, Inc. makes no warranty, representation or guarantee regarding the suitability of its product for any particular purpose, nor does Measurement Specialties, Inc. assume any liability arising out of the application or use of any product or circuit and specifically disclaims any and all liability, including without limitation consequential or incidental damages. Typical parameters can and do vary in different applications. All operating parameters must be validated for each customer application by customer's technical experts. Measurement Specialties, Inc. does not convey any license under its patent rights nor the rights of others.