

FN7325 Multiaxial Load Cell



- 6-Components Load Cell
- Range from 5 to 250 kN (1 to 50 kbf)
- Measures force in three directions X, Y, Z
- Measures torque in three directions Mx, My, Mz
- Minimal Cross Effects
- High Level Output Model with Integrated Amplifier

DESCRIPTION

The multi-axial **FN7325** measures force from 0-5 kN to 0-250 kN along three axes as well as the corresponding torque from 0-200 Nm to 0-7000 Nm. The **FN7325** is simple to use and install and in many diverse applications circumvents the necessity of employing multiple single-axes units. For high-level output a model with integrated amplifier is available.

With many years of experience as a designer and manufacturer of sensors, Measurement Specialties, Inc. often works with customers to design or customize sensors for specific uses and testing environments.

To meet your needs we also offer complete turnkey systems. The matched components (sensor, power, amplifier and digital display) are formatted, calibrated and ready for immediate use.

FEATURES

- Measures force and torque simultaneously
- Up to 6 components load cell
- Multiple and custom designs available
- Optional integrated amplifier
- Minimal Cross Effects

APPLICATIONS

- Mechanical linkage
- Structure testing
- Crash testing
- Automotive testing
- Industrial test benches

STANDARD RANGES

Model	FN7325-M6	FN7325-M8	FN7325-M10	FN7325-M12	FN7325-M16
Force X/Y in N [in lbf]	5k [1k]	15k [3k]	30k [6k]	60k [12k]	100k [20k]
Force Z in N [in lbf]	15k [3k]	30k [6k]	50k [10k]	100k [20k]	250k [50k]
Torque X/Y/Z in N/m [in lbf/ft]	200 [145]	600 [440]	1.2k [885]	2.8k [2 065]	7k [5 160]

FN7325 Multiaxial Load Cell

PERFORMANCE SPECIFICATIONS

All values are typical at temperature 20±1°C

PARAMETERS	
Operating Temperature Range (OTR)	-20 to 80° C [-4 to 176° F]
Compensated Temperature Range (CTR)	0 to 60° C (32 to 140° F)
Zero Shift in CTR	<1% F.S. / 50° C [100° F]
Sensitivity Shift in CTR	< 2% of reading / 50° C [100° F]
Ranges (F.S.)	See table
Over-Range	
Without Damage	1.2 x F.S.
Accuracy	
Combined non-linearity and hysteresis	±1% F.S. typical
Cross effects	3% F.S. typical (5% max.)

Electrical Characteristics

Model	FN7325	FN7325-A1	FN7325-A2
Supply Voltage	10 Vdc	10 - 30 Vdc	±15 Vdc (±12 to ±18Vdc)
F.S. Output ⁵	±10 -15 mV/V	±2V ±5% F.S.	±5 V ±5% F.S.
Zero Offset ⁵	±5% F.S.	2.5 V ±5% F.S.	0 V ±5% F.S.
Insulation under 50Vdc	≥100MΩ		

Notes

1. Electrical Termination: Connector output including mate
2. Wiring schematic depends on the sensor and number of channels
3. Materials: Body in stainless steel cover in aluminium alloy
4. Protection index: IP50
5. Other signal output on request
6. CE conformance according to EN 61010-1, EN 50081-1, EN 50082-1

FN7325 Multiaxial Load Cell

DIMENSIONS & WIRING SCHEMATIC (IN METRIC AND IMPERIAL)

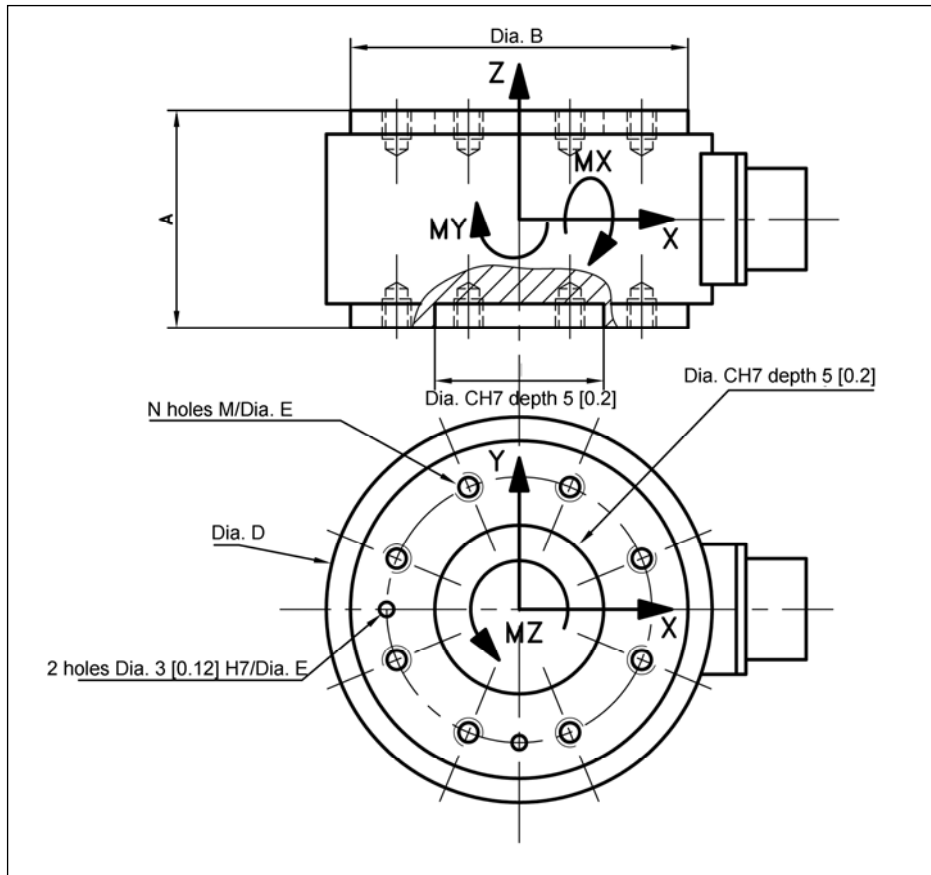

Wiring Schematic (per channel)

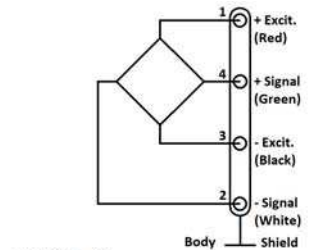

Version -A1

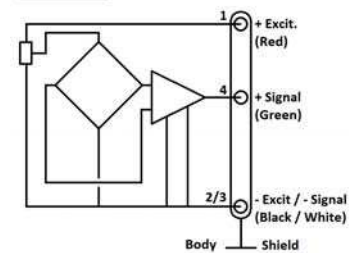

Version -A2

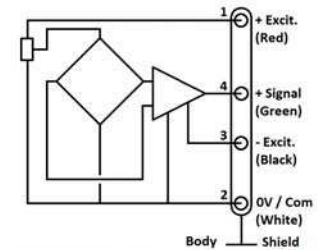

Dimensions in mm [inch]

Model	FN7325-M6	FN7325-M8	FN7325-M10	FN7325-M12	FN7325-M16
Force X/Y in N [in lbf]	5k [1k]	15k [3k]	30k [6k]	60k [12k]	100k [20k]
Force Z in N [in lbf]	15k [3k]	30k [6k]	50k [10k]	100k [20k]	250k [50k]
Torque X/Y/Z in N/m [in lbf/ft]	200 [145]	600 [440]	1.2k [885]	2.8k [2 065]	7k [5 160]
A	50 [1.97]	55 [2.17]	65 [2.56]	75 [2.95]	90 [3.54]
B	70 [2.76]	88 [3.46]	114 [4.49]	148 [5.83]	190 [7.48]
C	35 [1.38]	40 [1.57]	50 [1.97]	65 [2.56]	90 [3.54]
D	80 [3.15]	98 [3.86]	124 [4.88]	158 [6.22]	200 [7.87]
N	8 x M6/Ø55 [2.17]	8 x M8/ Ø70 [2.76]	8 x M10/Ø95 [3.74]	12 x M12/Ø125 [4.92]	12 x M16/Ø150 [5.91]

FN7325 Multiaxial Load Cell

OPTIONS

A1 : Amplified Tension output with unipolar power supply

A2 : Amplified Tension output with bipolar power supply

ORDERING INFO

FN7325 - A1 - M8

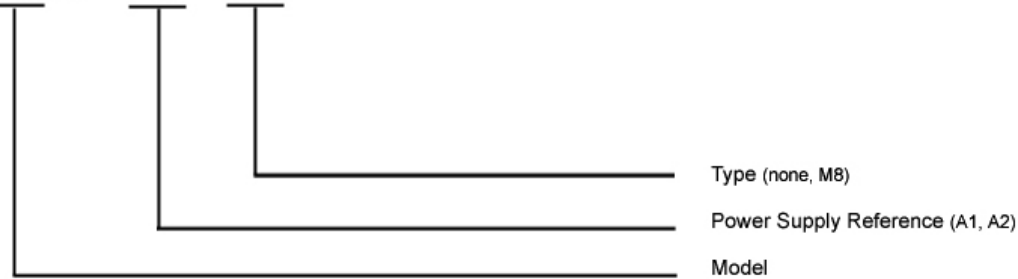

NORTH AMERICA

Measurement Specialties, Inc.
Vibration Design Center
32 Journey - Suite 150
Aliso Viejo, CA 92656
United States USA
Tel: 1-949-716-0877
Fax: 1-949-916-5677
t&m@meas-spec.com

EUROPE

Measurement Specialties
(Europe), Ltd.
26 Rue des Dames
78340 Les Clayes-Sous-Bois,
France
Tel: +33 (0) 130 79 33 00
Fax: +33 (0) 134 81 03 59
cs.lcsb@meas-spec.com

ASIA

Measurement Specialties
(China), Ltd.
No. 26 Langshan Road
Shenzhen High-Tech Park (North)
Nanshan District, Shenzhen
518057
China
Tel: +86 755 3330 5088
Fax: +86 755 3330 5099
pfg.cs.asia@meas-spec.com

The information in this sheet has been carefully reviewed and is believed to be accurate; however, no responsibility is assumed for inaccuracies. Furthermore, this information does not convey to the purchaser of such devices any license under the patent rights to the manufacturer. Measurement Specialties, Inc. reserves the right to make changes without further notice to any product herein. Measurement Specialties, Inc. makes no warranty, representation or guarantee regarding the suitability of its product for any particular purpose, nor does Measurement Specialties, Inc. assume any liability arising out of the application or use of any product or circuit and specifically disclaims any and all liability, including without limitation consequential or incidental damages. Typical parameters can and do vary in different applications. All operating parameters must be validated for each customer application by customer's technical experts. Measurement Specialties, Inc. does not convey any license under its patent rights nor the rights of others.