

FN7180-3 Friction Load Cell



- Measures force in two directions
 $F_x = F_z = 100 \text{ N}$
- Accuracy to <1% on each channel
- Integrated amplifier on request
- Rugged construction

DESCRIPTION

The **FN7180-3** is designed specifically to measure friction between two elements. Used mainly for automotive application, the sensor controls the efficiency of windshield soaps, elastomeric surfaces, oils and fluids under several conditions.

The sensor has small cross effects. Its high resolution and global accuracy allowed finest customer tests. The **FN7180** series can also be adjusted in a specific temperature range, and then monitor evolution of the criteria at different temperature steps.

With many years of experience as a designer and a manufacturer of sensors, Measurement Specialties, Inc. often works with customers to design or customize sensors for specific uses and testing environments.

FEATURES

- Measures F_x , F_z simultaneously
- High accuracy CN L&H < 1% FS
- Custom designs and interfaces available
- Optional integrated amplifier
- Minimal Cross Effects

APPLICATIONS

- Quality control test benches
- Windshield elements research
- Heavy slipping systems
- Automotive elastomeric components

STANDARD RANGES

Model	FN7180-3	
	X axis	Z axis
Range in N	100	100
Range in lbf	20	20

FN7180-3 Friction Load Cell

PERFORMANCE SPECIFICATIONS

All values are typical at temperature 20±1°C

PARAMETERS	
Operating Temperature Range (OTR)	-20 to 80° C [-4 to 176° F]
Compensated Temperature Range (CTR)	0 to 60° C (32 to 140° F)
Zero Shift in CTR	<2% F.S. / 50° C [100° F]
Sensitivity Shift in CTR	< 3% of reading / 50° C [100° F]
Ranges (F.S.)	See table
Over-Range	
Without Damage	1.5 x F.S.
Accuracy	
Combined non-linearity and hysteresis	±1% F.S.

Electrical Characteristics

Model	FN7180-3
Supply Outage	10 Vdc
F.S. Output channels Fx & Fz	± 20 mV/V
Zero Offset	±5% F.S.
Insulation under 50Vdc	≥100MΩ

Notes

1. Electrical Termination: cable gland with 2m shielded cable or plug
2. Materials: Body and cover in aluminium alloy
3. Protection index: IP50
4. CE conformance according to EN 61010-1, EN 50081-1, EN 50082-1

FN7180-3 Friction Load Cell

DIMENSIONS & WIRING SCHEMATIC (IN METRIC)

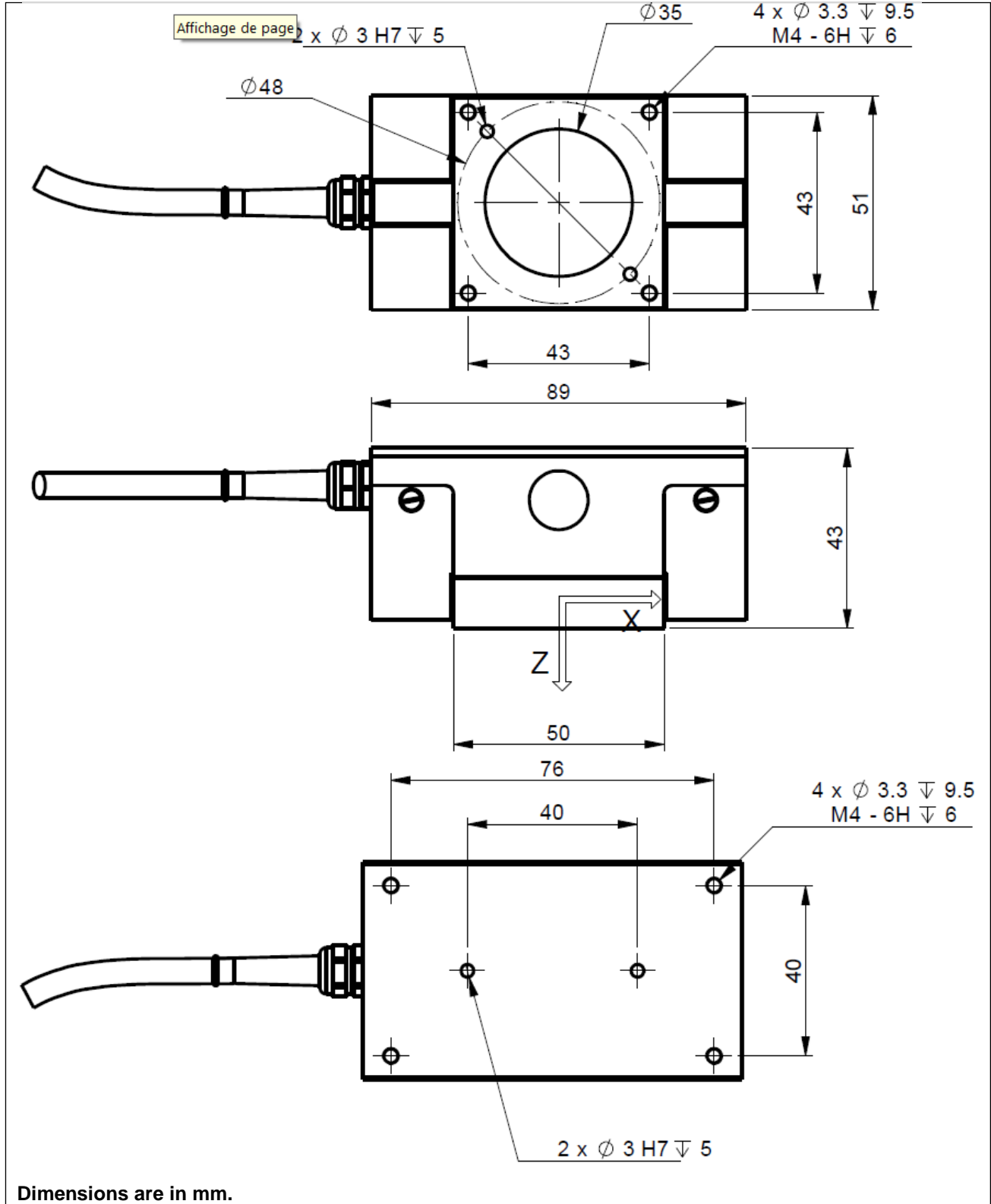

FN7180-3 Friction Load Cell

OPTIONS

L00M: Special Cable Length, replace "00" with total length in meter

ORDERING INFORMATION

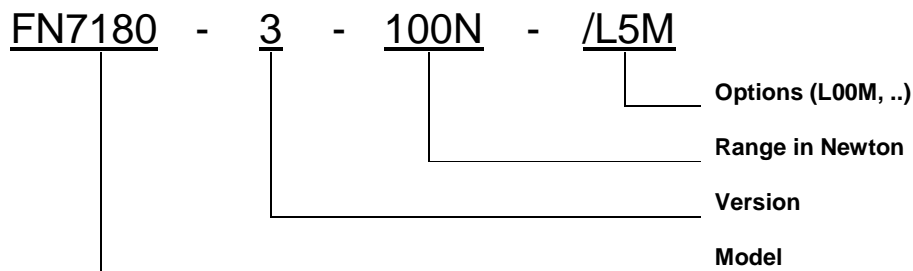

NORTH AMERICA

Measurement Specialties, Inc.
Vibration Design Center
32 Journey - Suite 150
Aliso Viejo, CA 92656
United States USA
Tel: 1-949-716-0877
Fax: 1-949-916-5677
t&m@meas-spec.com

EUROPE

Measurement Specialties
(Europe), Ltd.
26 Rue des Dames
78340 Les Clayes-Sous-Bois,
France
Tel: +33 (0) 130 79 33 00
Fax: +33 (0) 134 81 03 59
cs.lcsb@meas-spec.com

ASIA

Measurement Specialties
(China), Ltd.
No. 26 Langshan Road
Shenzhen High-Tech Park (North)
Nanshan District, Shenzhen
518057
China
Tel: +86 755 3330 5088
Fax: +86 755 3330 5099
pfg.cs.asia@meas-spec.com

The information in this sheet has been carefully reviewed and is believed to be accurate; however, no responsibility is assumed for inaccuracies. Furthermore, this information does not convey to the purchaser of such devices any license under the patent rights to the manufacturer. Measurement Specialties, Inc. reserves the right to make changes without further notice to any product herein. Measurement Specialties, Inc. makes no warranty, representation or guarantee regarding the suitability of its product for any particular purpose, nor does Measurement Specialties, Inc. assume any liability arising out of the application or use of any product or circuit and specifically disclaims any and all liability, including without limitation consequential or incidental damages. Typical parameters can and do vary in different applications. All operating parameters must be validated for each customer application by customer's technical experts. Measurement Specialties, Inc. does not convey any license under its patent rights nor the rights of others.