

74LVC841A

10-bit transparent latch with 5 V tolerant inputs/outputs;
3-state

Rev. 03 — 24 May 2004

Product data sheet

1. General description

The 74LVC841A is a high performance, low-power, low-voltage Si-gate CMOS device and superior to most advanced CMOS compatible TTL families.

Inputs can be driven from either 3.3 V or 5 V devices. In 3-state operation, outputs can handle 5 V. This feature allows the use of these devices as translators in a mixed 3.3 V and 5 V environment.

The 74LVC841A is a 10-bit transparent latch featuring separate D-type inputs for each latch and 3-state outputs for bus-oriented applications. A latch enable (pin \overline{LE}) input and an output enable (pin \overline{OE}) input are common to all internal latches. The 74LVC841A consists of ten transparent latches with 3-state true outputs. When pin LE is HIGH, data at the Dn inputs enters the latches. In this condition the latches are transparent, i.e., a latch output will change each time its corresponding D-input changes. When pin \overline{LE} is LOW the latches store the information that was present at the D-inputs a set-up time preceding the HIGH-to-LOW transition of pin \overline{LE} . When pin \overline{OE} is LOW, the contents of the ten latches are available at the outputs. When pin \overline{OE} is HIGH, the outputs go to the high-impedance OFF-state. Operation of the pin \overline{OE} input does not affect the state of the latches.

2. Features

- 5 V tolerant inputs/outputs; for interfacing with 5 V logic
- Wide supply voltage range from 1.2 V to 3.6 V
- Inputs accept voltages up to 5.5 V
- CMOS low power consumption
- Direct interface with TTL levels
- Flow-through pin-out architecture
- Complies with JEDEC standard JESD8B/JESD36
- ESD protection:
 - ◆ HBM EIA/JESD22-A114-B exceeds 2000 V
 - ◆ MM EIA/JESD22-A115-A exceeds 200 V.
- Specified from $-40\text{ }^{\circ}\text{C}$ to $+85\text{ }^{\circ}\text{C}$ and $-40\text{ }^{\circ}\text{C}$ to $+125\text{ }^{\circ}\text{C}$.

PHILIPS

3. Quick reference data

Table 1: Quick reference data

$GND = 0\text{ V}$; $T_{amb} = 25\text{ °C}$; $t_r = t_f \leq 2.5\text{ ns}$.

Symbol	Parameter	Conditions	Min	Typ	Max	Unit
t_{PHL} , t_{PLH}	propagation delay Dn to Qn	$C_L = 50\text{ pF}$; $V_{CC} = 3.3\text{ V}$	-	3.0	-	ns
	propagation delay LE to Qn	$C_L = 50\text{ pF}$; $V_{CC} = 3.3\text{ V}$	-	3.4	-	ns
t_{PZH} , t_{PZL}	3-state output enable time OE to Qn	$C_L = 50\text{ pF}$; $V_{CC} = 3.3\text{ V}$	-	3.5	-	ns
t_{PHZ} , t_{PLZ}	3-state output disable time OE to Qn	$C_L = 50\text{ pF}$; $V_{CC} = 3.3\text{ V}$	-	2.9	-	ns
C_I	input capacitance		-	5.0	-	pF
C_{PD}	power dissipation capacitance per latch	$V_{CC} = 3.3\text{ V}$	[1] [2]			
		outputs enabled	-	13	-	pF
		outputs disabled	-	4	-	pF

[1] C_{PD} is used to determine the dynamic power dissipation (P_D in μW).

$P_D = C_{PD} \times V_{CC}^2 \times f_i \times N + \Sigma(C_L \times V_{CC}^2 \times f_o)$ where:

f_i = input frequency in MHz;

f_o = output frequency in MHz;

C_L = output load capacitance in pF;

V_{CC} = supply voltage in Volts;

N = total load switching outputs;

$\Sigma(C_L \times V_{CC}^2 \times f_o)$ = sum of the outputs.

[2] The condition is $V_I = GND$ to V_{CC} .

4. Ordering information

Table 2: Ordering information

Type number	Package			Version
	Temperature range	Name	Description	
74LVC841AD	-40 °C to +125 °C	SO24	plastic small outline package; 24 leads; body width 7.5 mm	SOT137-1
74LVC841ADB	-40 °C to +125 °C	SSOP24	plastic shrink small outline package; 24 leads; body width 5.3 mm	SOT340-1
74LVC841APW	-40 °C to +125 °C	TSSOP24	plastic thin shrink small outline package; 24 leads; body width 4.4 mm	SOT355-1
74LVC841ABQ	-40 °C to +125 °C	DHVQFN24	plastic dual in-line compatible thermal enhanced very thin quad flat package; no leads; 24 terminals; body 3.5 x 5.5 x 0.85 mm	SOT815-1

5. Functional diagram

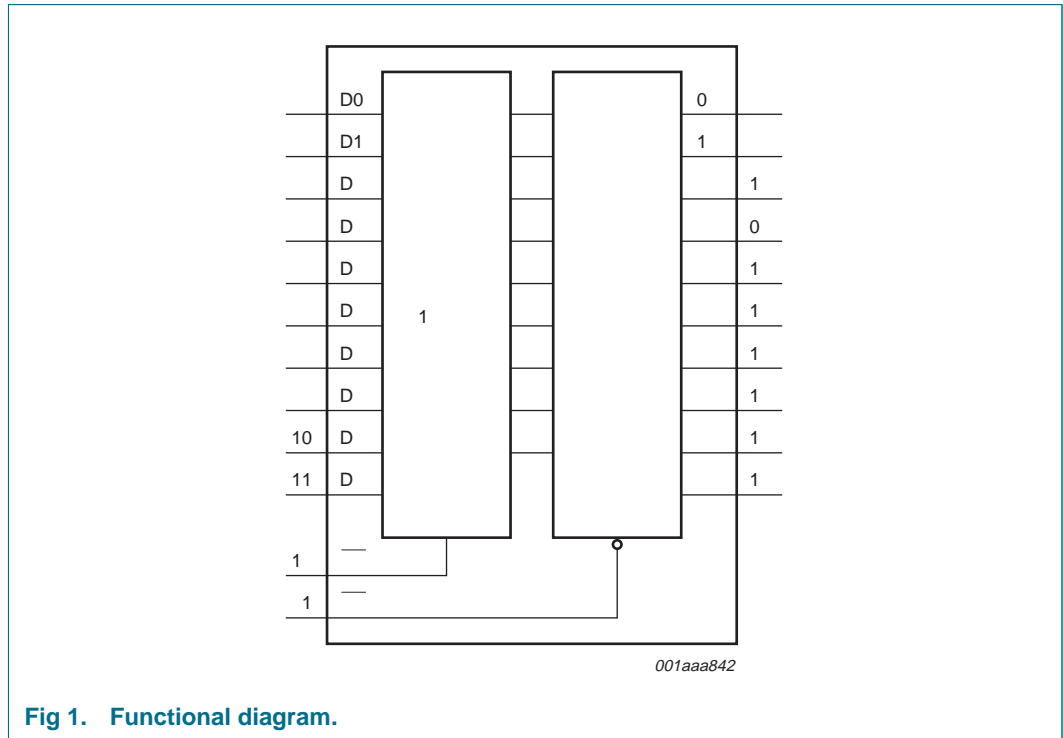

Fig 1. Functional diagram.

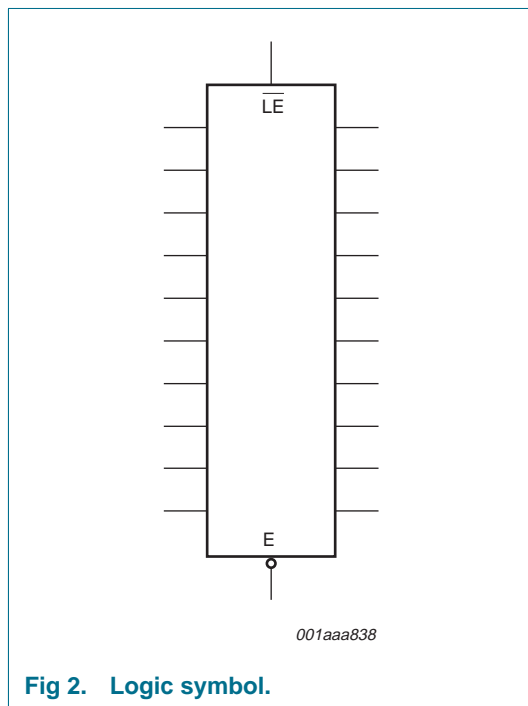

Fig 2. Logic symbol.

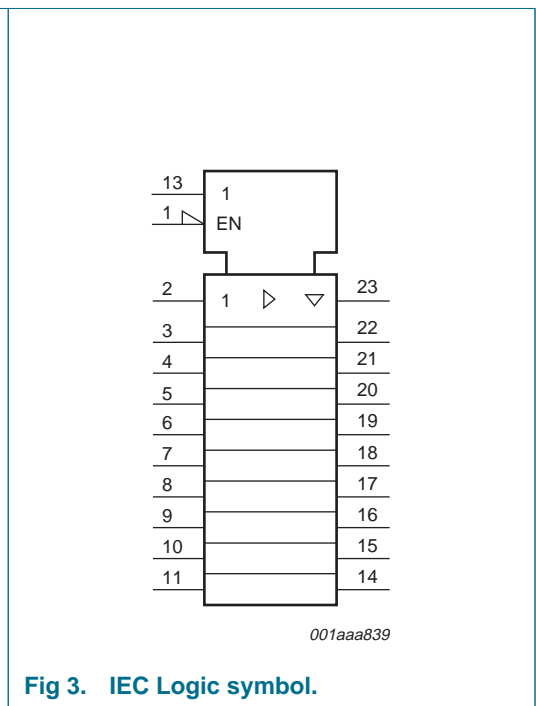

Fig 3. IEC Logic symbol.

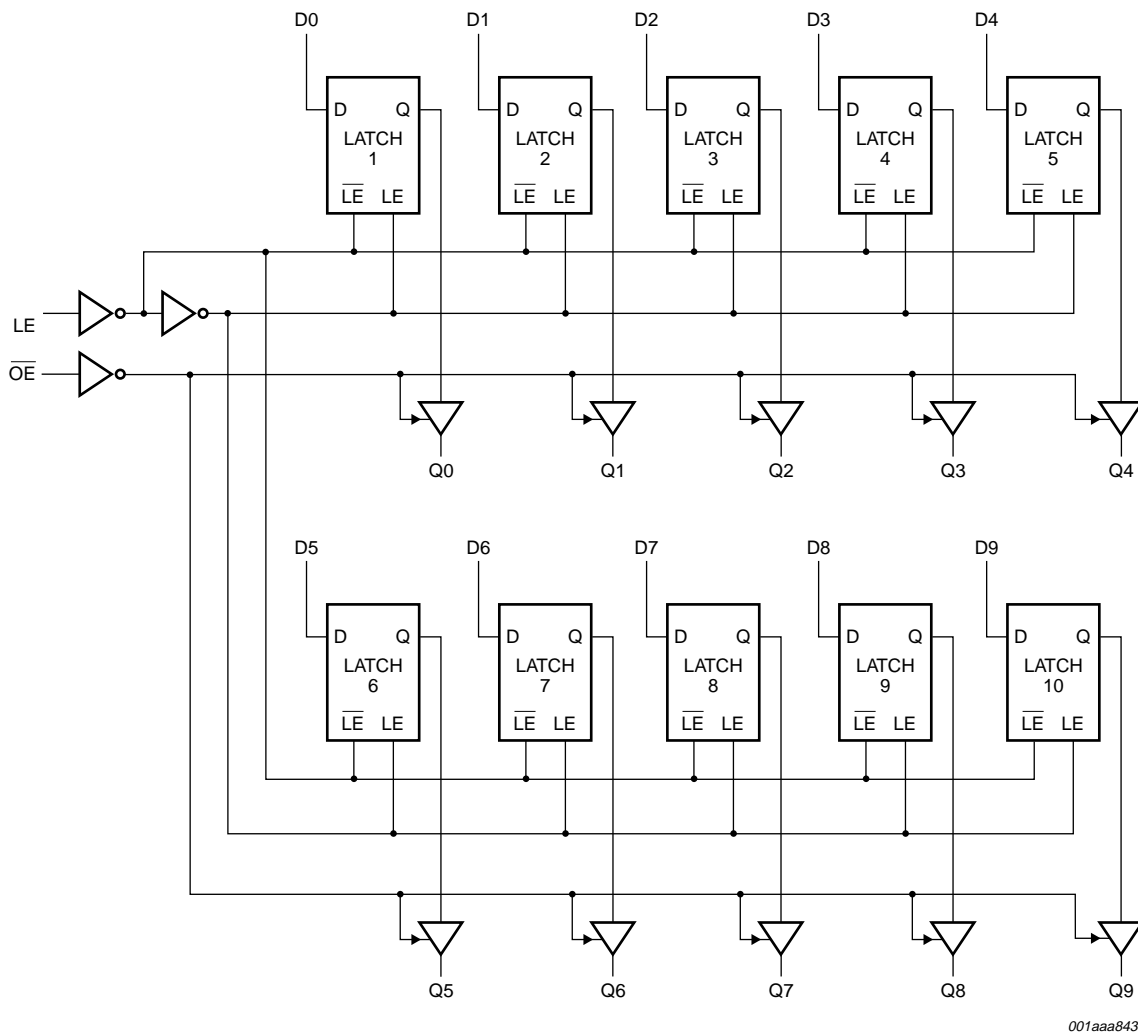
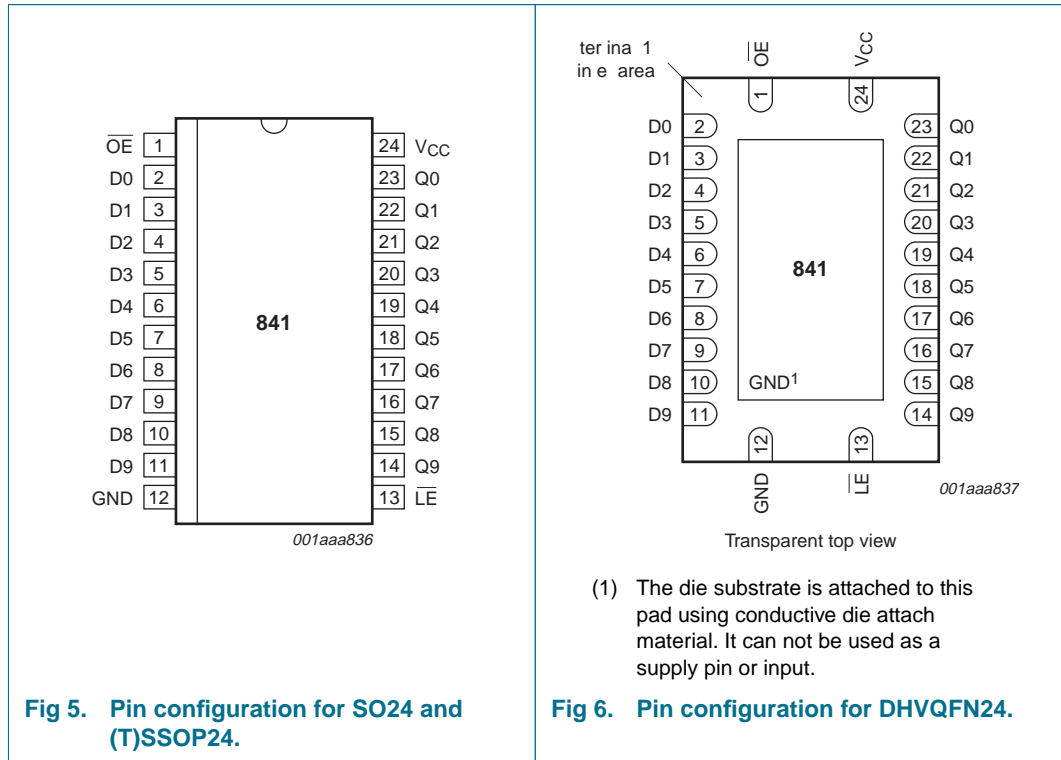

Fig 4. Logic diagram

6. Pinning information

6.1 Pinning



6.2 Pin description

Table 3: Pin description

Pin	Symbol	Description
1	\overline{OE}	output enable input (active LOW)
2	D0	data input
3	D1	data input
4	D2	data input
5	D3	data input
6	D4	data input
7	D5	data input
8	D6	data input
9	D7	data input
10	D8	data input
11	D9	data input
12	GND	ground (0 V)
13	\overline{LE}	latch enable input (active LOW)
14	Q9	3-state latch output
15	Q8	3-state latch output

Table 3: Pin description ...continued

Pin	Symbol	Description
16	Q7	3-state latch output
17	Q6	3-state latch output
18	Q5	3-state latch output
19	Q4	3-state latch output
20	Q3	3-state latch output
21	Q2	3-state latch output
22	Q1	3-state latch output
23	Q0	3-state latch output
24	V _{CC}	supply voltage

7. Functional description

7.1 Function table

Table 4: Function table [1]

Operating mode	Input			Internal latches	Output Q _n
	\overline{OE}	LE	D _n		
Enable and read register (transparent mode)	L	H	L	L	L
	L	H	H	H	H
Latch and read register	L	L	l	L	L
	L	L	h	H	H
Latch register and disable outputs	H	L	l	L	Z
	H	L	h	H	Z
Hold	L	L	X	NC	NC

- [1] H = HIGH voltage level;
h = HIGH voltage level one set-up time prior to the HIGH-to-LOW LE transition;
L = LOW voltage level;
l = LOW voltage level one set-up time prior to the HIGH-to-LOW LE transition;
Z = high-impedance OFF-state;
NC = no change;
X = don't care.

8. Limiting values

Table 5: Limiting values

In accordance with the Absolute Maximum Rating System (IEC 60134). Voltages are referenced to GND (ground = 0 V).

Symbol	Parameter	Conditions	Min	Max	Unit
V _{CC}	supply voltage		-0.5	+6.5	V
I _{IK}	input diode current	V _I < 0 V	-	-50	mA
V _I	input voltage		[1] -0.5	+6.5	V
I _{OK}	output diode current	V _O > V _{CC} or V _O < 0 V	-	±50	mA

Table 5: Limiting values ...continued

In accordance with the Absolute Maximum Rating System (IEC 60134). Voltages are referenced to GND (ground = 0 V).

Symbol	Parameter	Conditions	Min	Max	Unit
V_O	output voltage	HIGH or LOW state	[1] -0.5	$V_{CC} + 0.5$	V
		3-state	[1] -0.5	+6.5	V
I_O	output source or sink current	$V_O = 0\text{ V to }V_{CC}$	-	±50	mA
I_{CC}, I_{GND}	V_{CC} or GND current		-	±100	mA
T_{stg}	storage temperature		-65	+150	°C
P_{tot}	power dissipation	$T_{amb} = -40\text{ °C to }+125\text{ °C}$	[2] -	500	mW

[1] The input and output voltage ratings may be exceeded if the input and output current ratings are observed.

[2] For SO24 packages: above 70 °C derate linearly with 8 mW/K.
 For (T)SSOP24 packages: above 60 °C derate linearly with 5.5 mW/K.
 For DHVQFN24 packages: above 60 °C derate linearly with 4.5 mW/K.

9. Recommended operating conditions

Table 6: Recommended operating conditions

Symbol	Parameter	Conditions	Min	Max	Unit
V_{CC}	supply voltage	for maximum speed performance	2.7	3.6	V
		for low-voltage applications	1.2	3.6	V
V_I	input voltage		0	5.5	V
V_O	output voltage	HIGH or LOW state	0	V_{CC}	V
		3-state	0	5.5	V
T_{amb}	operating ambient temperature	in free air	-40	+125	°C
t_r, t_f	input rise and fall times	$V_{CC} = 1.2\text{ V to }2.7\text{ V}$	0	20	ns/V
		$V_{CC} = 2.7\text{ V to }3.6\text{ V}$	0	10	ns/V

10. Static characteristics

Table 7: Static characteristics

At recommended operating conditions; voltages are referenced to GND (ground = 0 V).

Symbol	Parameter	Conditions	Min	Typ	Max	Unit
$T_{amb} = -40\text{ °C to }+85\text{ °C}$ [1]						
V_{IH}	HIGH-level input voltage	$V_{CC} = 1.2\text{ V}$	V_{CC}	-	-	V
		$V_{CC} = 2.7\text{ V to }3.6\text{ V}$	2.0	-	-	V
V_{IL}	LOW-level input voltage	$V_{CC} = 1.2\text{ V}$	-	-	GND	V
		$V_{CC} = 2.7\text{ V to }3.6\text{ V}$	-	-	0.8	V

Table 7: Static characteristics ...continued

At recommended operating conditions; voltages are referenced to GND (ground = 0 V).

Symbol	Parameter	Conditions	Min	Typ	Max	Unit
V _{OH}	HIGH-level output voltage	V _I = V _{IH} or V _{IL} I _O = -100 μA; V _{CC} = 2.7 V to 3.6 V	V _{CC} - 0.2	V _{CC} [2]	-	V
		I _O = -12 mA; V _{CC} = 2.7 V	V _{CC} - 0.5	-	-	V
		I _O = -18 mA; V _{CC} = 3.0 V	V _{CC} - 0.6	-	-	V
		I _O = -24 mA; V _{CC} = 3.0 V	V _{CC} - 0.8	-	-	V
V _{OL}	LOW-level output voltage	V _I = V _{IH} or V _{IL} I _O = 100 μA; V _{CC} = 2.7 V to 3.6 V	[2] -	GND	0.2	V
		I _O = 12 mA; V _{CC} = 2.7 V	-	-	0.4	V
		I _O = 24 mA; V _{CC} = 3.0 V	-	-	0.55	V
I _{LI}	input leakage current	V _I = 5.5 V or GND; V _{CC} = 3.6 V	-	±0.1	±5	μA
I _{OZ}	3-state output OFF-state current	V _I = V _{IH} or V _{IL} ; V _O = 5.5 V or GND; V _{CC} = 3.6 V	-	0.1	±5	μA
I _{off}	power-off leakage supply	V _I or V _O = 5.5 V; V _{CC} = 0.0 V	-	0.1	±10	μA
I _{CC}	quiescent supply current	V _I = V _{CC} or GND; I _O = 0 A; V _{CC} = 3.6 V	-	0.1	10	μA
ΔI _{CC}	additional quiescent supply current per pin	V _I = V _{CC} - 0.6 V; I _O = 0 A; V _{CC} = 2.7 V to 3.6 V	[2] -	5	500	μA
C _I	input capacitance		-	5.0	-	pF
T_{amb} = -40 °C to +125 °C						
V _{IH}	HIGH-level input voltage	V _{CC} = 1.2 V	V _{CC}	-	-	V
		V _{CC} = 2.7 V to 3.6 V	2.0	-	-	V
V _{IL}	LOW-level input voltage	V _{CC} = 1.2 V	-	-	GND	V
		V _{CC} = 2.7 V to 3.6 V	-	-	0.8	V
V _{OH}	HIGH-level output voltage	V _I = V _{IH} or V _{IL} I _O = -100 μA; V _{CC} = 2.7 V to 3.6 V	V _{CC} - 0.3	-	-	V
		I _O = -12 mA; V _{CC} = 2.7 V	V _{CC} - 0.65	-	-	V
		I _O = -18 mA; V _{CC} = 3.0 V	V _{CC} - 0.75	-	-	V
		I _O = -24 mA; V _{CC} = 3.0 V	V _{CC} - 1	-	-	V
V _{OL}	LOW-level output voltage	V _I = V _{IH} or V _{IL} I _O = 100 μA; V _{CC} = 2.7 V to 3.6 V	-	-	0.3	V
		I _O = 12 mA; V _{CC} = 2.7 V	-	-	0.6	V
		I _O = 24 mA; V _{CC} = 3.0 V	-	-	0.8	V
I _{LI}	input leakage current	V _I = 5.5 V or GND; V _{CC} = 3.6 V	-	-	±20	μA
I _{OZ}	3-state output OFF-state current	V _I = V _{IH} or V _{IL} ; V _O = 5.5 V or GND; V _{CC} = 3.6 V	-	-	±20	μA

Table 7: Static characteristics ...continued

At recommended operating conditions; voltages are referenced to GND (ground = 0 V).

Symbol	Parameter	Conditions	Min	Typ	Max	Unit
I_{off}	power-off leakage supply	V_I or $V_O = 5.5$ V; $V_{CC} = 0.0$ V	-	-	± 20	μ A
I_{CC}	quiescent supply current	$V_I = V_{CC}$ or GND; $I_O = 0$ A; $V_{CC} = 3.6$ V	-	-	40	μ A
ΔI_{CC}	additional quiescent supply current per pin	$V_I = V_{CC} - 0.6$ V; $I_O = 0$ A; $V_{CC} = 2.7$ V to 3.6 V	-	-	5000	μ A

[1] All typical values are measured $T_{amb} = 25$ °C.[2] These typical values are measured at $V_{CC} = 3.3$ V.

11. Dynamic characteristics

Table 8: Dynamic characteristicsGND = 0 V; $t_r = t_f \leq 2.5$ ns; $C_L = 50$ pF; $R_L = 500$ Ω .

Symbol	Parameter	Conditions	Min	Typ	Max	Unit	
$T_{amb} = -40$ °C to $+85$ °C [1]							
t_{PHL} , t_{PLH}	propagation delay Dn to Qn	see Figure 7 and 11					
		$V_{CC} = 1.2$ V	-	15	-	ns	
		$V_{CC} = 2.7$ V	1.5	-	7.5	ns	
		$V_{CC} = 3.0$ V to 3.6 V	[2] 1.5	3.0	6.7	ns	
	propagation delay LE to Qn	see Figure 8 and 11					
		$V_{CC} = 1.2$ V	-	17	-	ns	
$V_{CC} = 2.7$ V		1.5	-	8.6	ns		
	$V_{CC} = 3.0$ V to 3.6 V	[2] 1.5	3.4	7.6	ns		
t_{PZH} , t_{PZL}	3-state output enable time \overline{OE} to Qn	see Figure 10 and 11					
		$V_{CC} = 1.2$ V	-	19	-	ns	
		$V_{CC} = 2.7$ V	1.5	-	8.5	ns	
	$V_{CC} = 3.0$ V to 3.6 V	[2] 1.5	3.5	7.2	ns		
t_{PHZ} , t_{PLZ}	3-state output disable time \overline{OE} to Qn	see Figure 10 and 11					
		$V_{CC} = 1.2$ V	-	8.0	-	ns	
		$V_{CC} = 2.7$ V	1.5	-	6.6	ns	
	$V_{CC} = 3.0$ V to 3.6 V	[2] 1.5	2.9	5.9	ns		
t_W	LE pulse width HIGH	see Figure 8					
		$V_{CC} = 1.2$ V	-	-	-	ns	
		$V_{CC} = 2.7$ V	2.0	-	-	ns	
	$V_{CC} = 3.0$ V to 3.6 V	[2] 2.0	0.7	-	ns		

Table 8: Dynamic characteristics ...continued
GND = 0 V; $t_r = t_f \leq 2.5$ ns; $C_L = 50$ pF; $R_L = 500$ Ω .

Symbol	Parameter	Conditions	Min	Typ	Max	Unit	
t_{su}	set-up time Dn to LE	see Figure 9					
		$V_{CC} = 1.2$ V	-	-	-	ns	
		$V_{CC} = 2.7$ V	2.0	-	-	ns	
		$V_{CC} = 3.0$ V to 3.6 V	[2] 2.0	1.0	-	ns	
t_h	hold time Dn to LE	see Figure 9					
		$V_{CC} = 1.2$ V	-	-	-	ns	
		$V_{CC} = 2.7$ V	1.0	-	-	ns	
		$V_{CC} = 3.0$ V to 3.6 V	[2] 1.0	0.0	-	ns	
$t_{sk(0)}$	skew	$V_{CC} = 3.0$ V to 3.6 V	[3] -	-	1.0	ns	
C_{PD}	power dissipation capacitance per latch	$V_{CC} = 3.3$ V	[4] [5]				
		outputs enabled	-	13	-	pF	
		outputs disabled	-	4	-	pF	
$T_{amb} = -40$ °C to $+125$ °C							
t_{PHL}, t_{PLH}	propagation delay Dn to Qn	see Figure 7 and 11					
		$V_{CC} = 1.2$ V	-	-	-	ns	
		$V_{CC} = 2.7$ V	1.5	-	9.5	ns	
			$V_{CC} = 3.0$ V to 3.6 V	1.5	-	8.5	ns
	propagation delay LE to Qn	see Figure 8 and 11					
		$V_{CC} = 1.2$ V	-	-	-	ns	
$V_{CC} = 2.7$ V		1.5	-	11.0	ns		
		$V_{CC} = 3.0$ V to 3.6 V	1.5	-	9.5	ns	
t_{PZH}, t_{PZL}	3-state output enable time \overline{OE} to Qn	see Figure 10 and 11					
		$V_{CC} = 1.2$ V	-	-	-	ns	
		$V_{CC} = 2.7$ V	1.5	-	11.0	ns	
		$V_{CC} = 3.0$ V to 3.6 V	1.5	-	9.0	ns	
t_{PHZ}, t_{PLZ}	3-state output disable time \overline{OE} to Qn	see Figure 10 and 11					
		$V_{CC} = 1.2$ V	-	-	-	ns	
		$V_{CC} = 2.7$ V	1.5	-	8.5	ns	
		$V_{CC} = 3.0$ V to 3.6 V	1.5	-	7.5	ns	
t_W	LE pulse width HIGH	see Figure 8					
		$V_{CC} = 1.2$ V	-	-	-	ns	
		$V_{CC} = 2.7$ V	2.0	-	-	ns	
		$V_{CC} = 3.0$ V to 3.6 V	2.0	-	-	ns	
t_{su}	set-up time Dn to LE	see Figure 9					
		$V_{CC} = 1.2$ V	-	-	-	ns	
		$V_{CC} = 2.7$ V	2.0	-	-	ns	
		$V_{CC} = 3.0$ V to 3.6 V	2.0	-	-	ns	

Table 8: Dynamic characteristics ...continued
GND = 0 V; $t_r = t_f \leq 2.5$ ns; $C_L = 50$ pF; $R_L = 500$ Ω .

Symbol	Parameter	Conditions	Min	Typ	Max	Unit
t_h	hold time Dn to LE	see Figure 9				
		$V_{CC} = 1.2$ V	-	-	-	ns
		$V_{CC} = 2.7$ V	1.0	-	-	ns
		$V_{CC} = 3.0$ V to 3.6 V	1.0	-	-	ns
$t_{sk(0)}$	skew	$V_{CC} = 3.0$ V to 3.6 V	[3]	-	1.5	ns

- [1] All typical values are measured $T_{amb} = 25$ °C.
- [2] These typical values are measured at $V_{CC} = 3.3$ V.
- [3] Skew between any two outputs of the same package switching in the same direction. This parameter is guaranteed by design.
- [4] C_{PD} is used to determine the dynamic power dissipation (P_D in μ W).
 $P_D = C_{PD} \times V_{CC}^2 \times f_i \times N + \Sigma(C_L \times V_{CC}^2 \times f_o)$ where:
 f_i = input frequency in MHz;
 f_o = output frequency in MHz;
 C_L = output load capacitance in pF;
 V_{CC} = supply voltage in Volts;
 N = total load switching outputs;
 $\Sigma(C_L \times V_{CC}^2 \times f_o)$ = sum of the outputs.
- [5] The condition is $V_i = GND$ to V_{CC} .

12. Waveforms

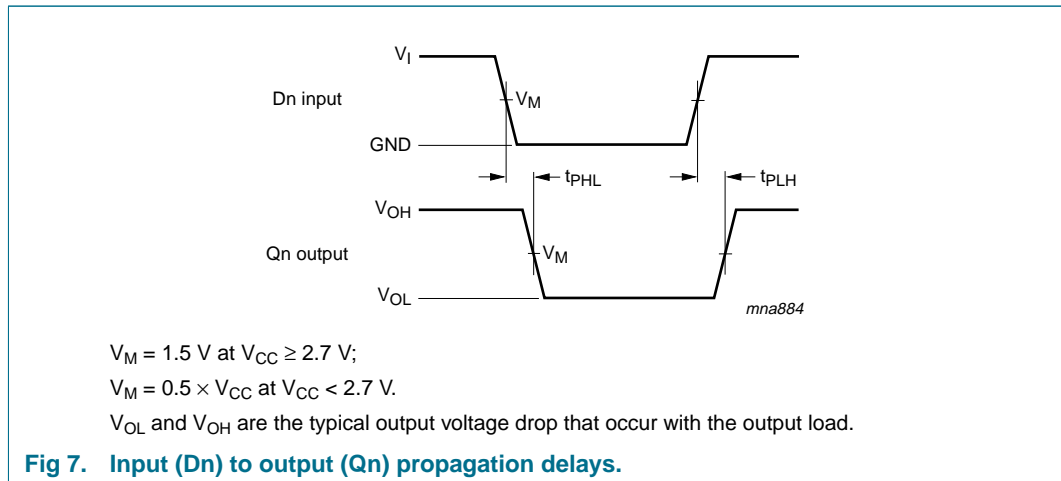

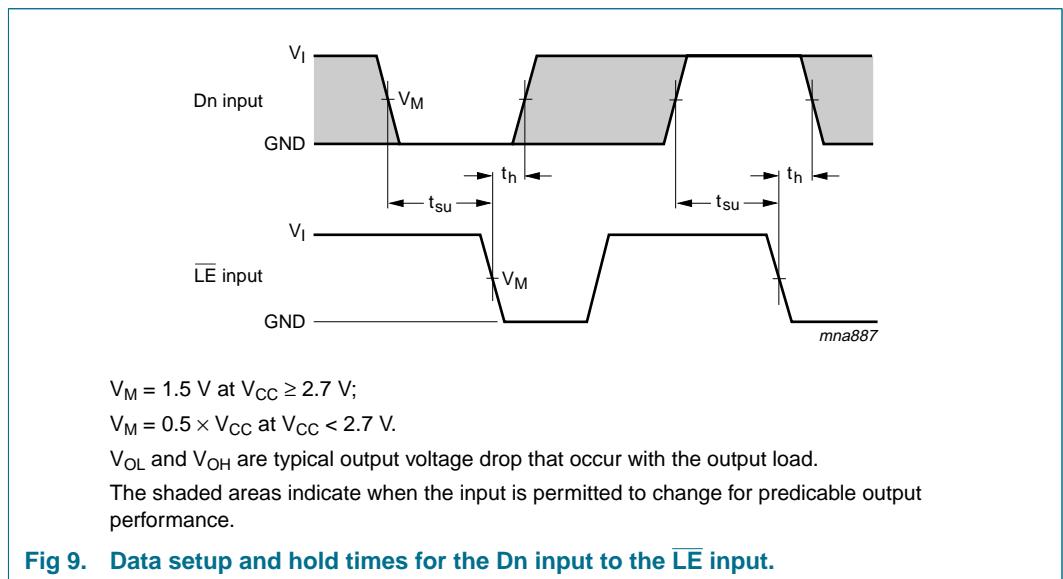
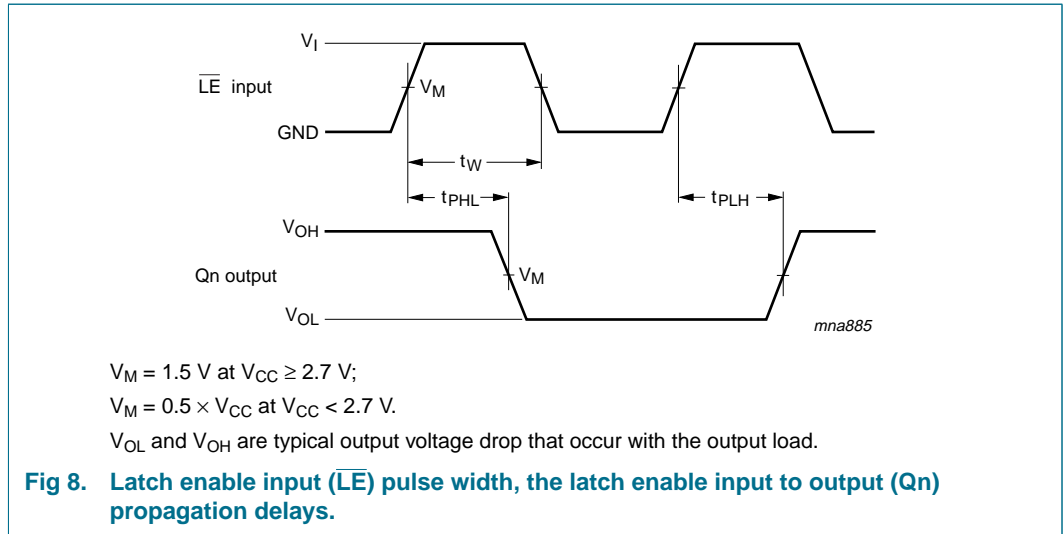

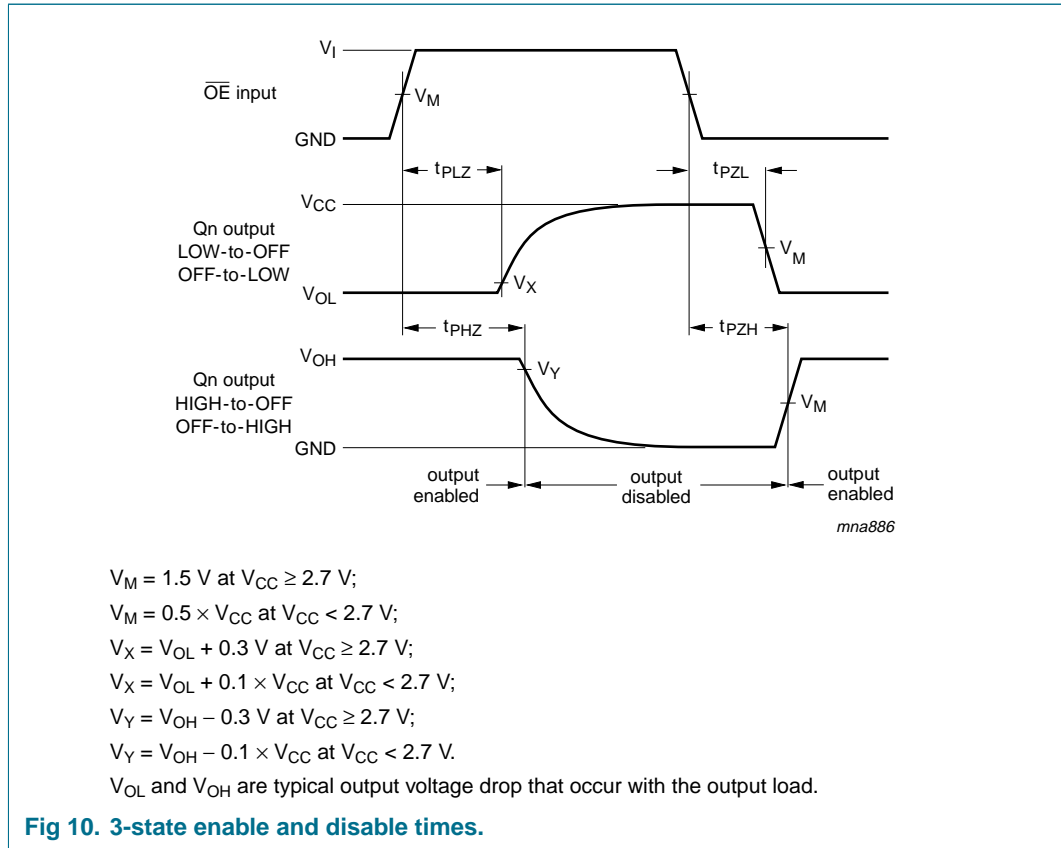

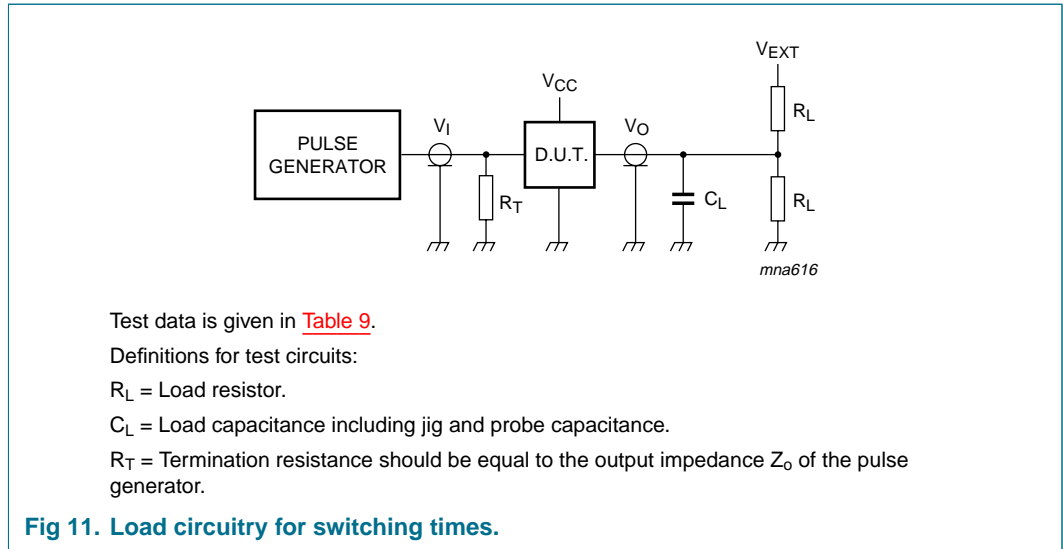

Table 9: Measurement points

Supply voltage	Input	Load		V_{EXT}		
V_{CC}	V_I	C_L	R_L	t_{PLH}, t_{PHL}	t_{PZH}, t_{PHZ}	t_{PZL}, t_{PLZ}
1.2 V	V_{CC}	50 pF	500 Ω [1]	open	GND	$2 \times V_{CC}$
2.7 V	2.7 V	50 pF	500 Ω	open	GND	$2 \times V_{CC}$
3.0 V to 3.6 V	2.7 V	50 pF	500 Ω	open	GND	$2 \times V_{CC}$

[1] The circuit performs better when $R_L = 1000 \Omega$.

13. Package outline

SO24: plastic small outline package; 24 leads; body width 7.5 mm

SOT137-1

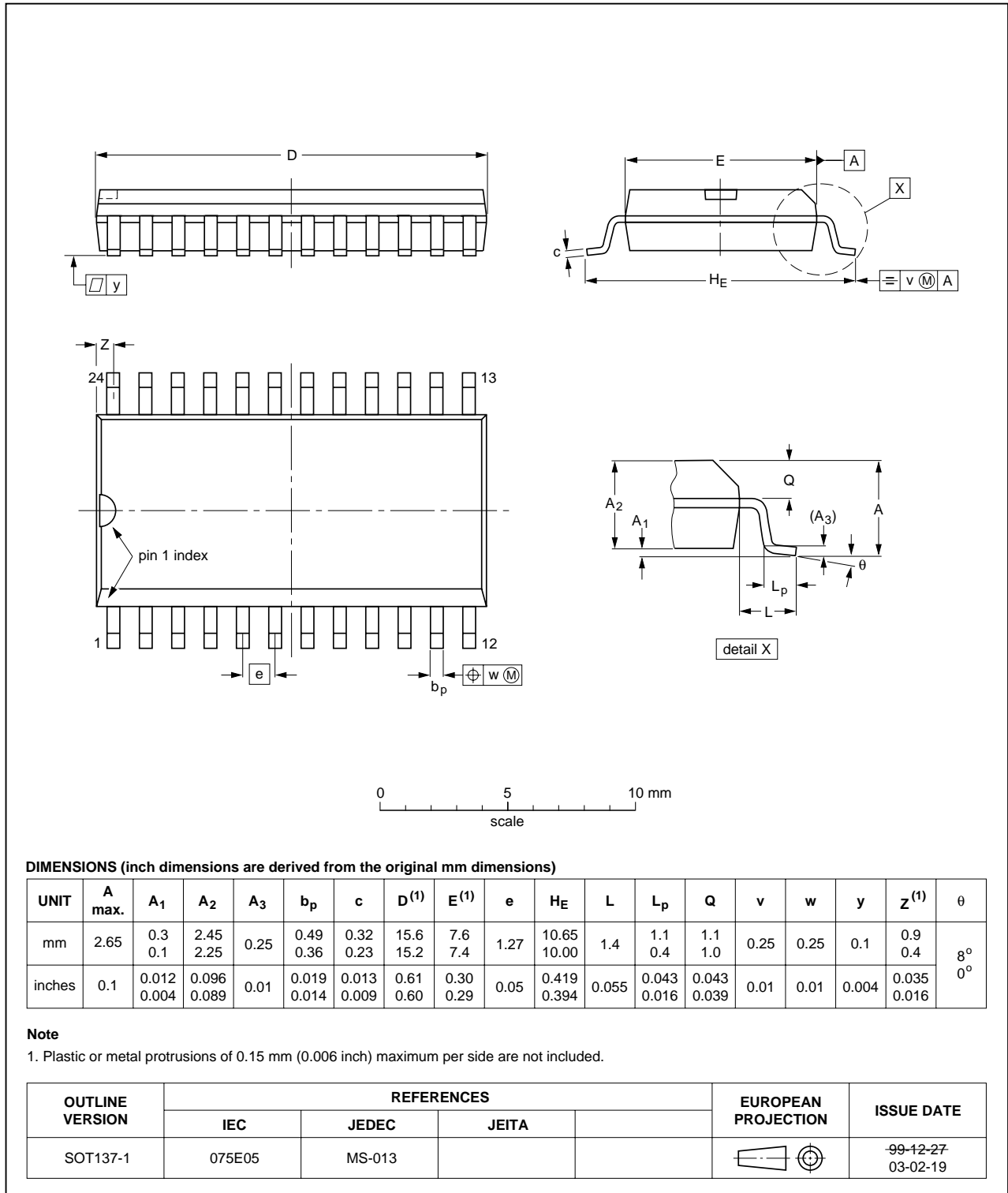

Fig 12. Package outline SO24.

SSOP24: plastic shrink small outline package; 24 leads; body width 5.3 mm

SOT340-1

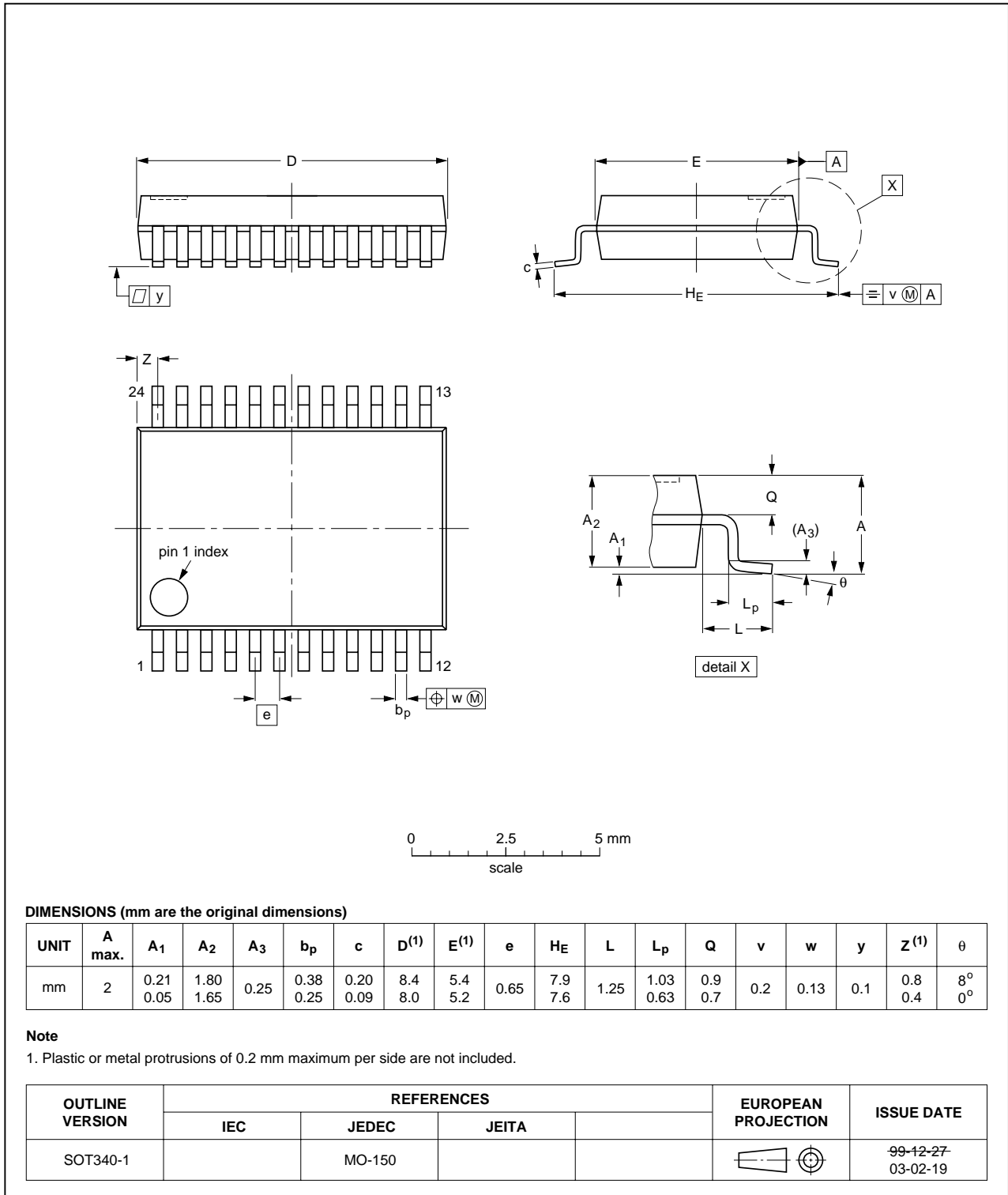

Fig 13. Package outline SSOP24.

TSSOP24: plastic thin shrink small outline package; 24 leads; body width 4.4 mm

SOT355-1

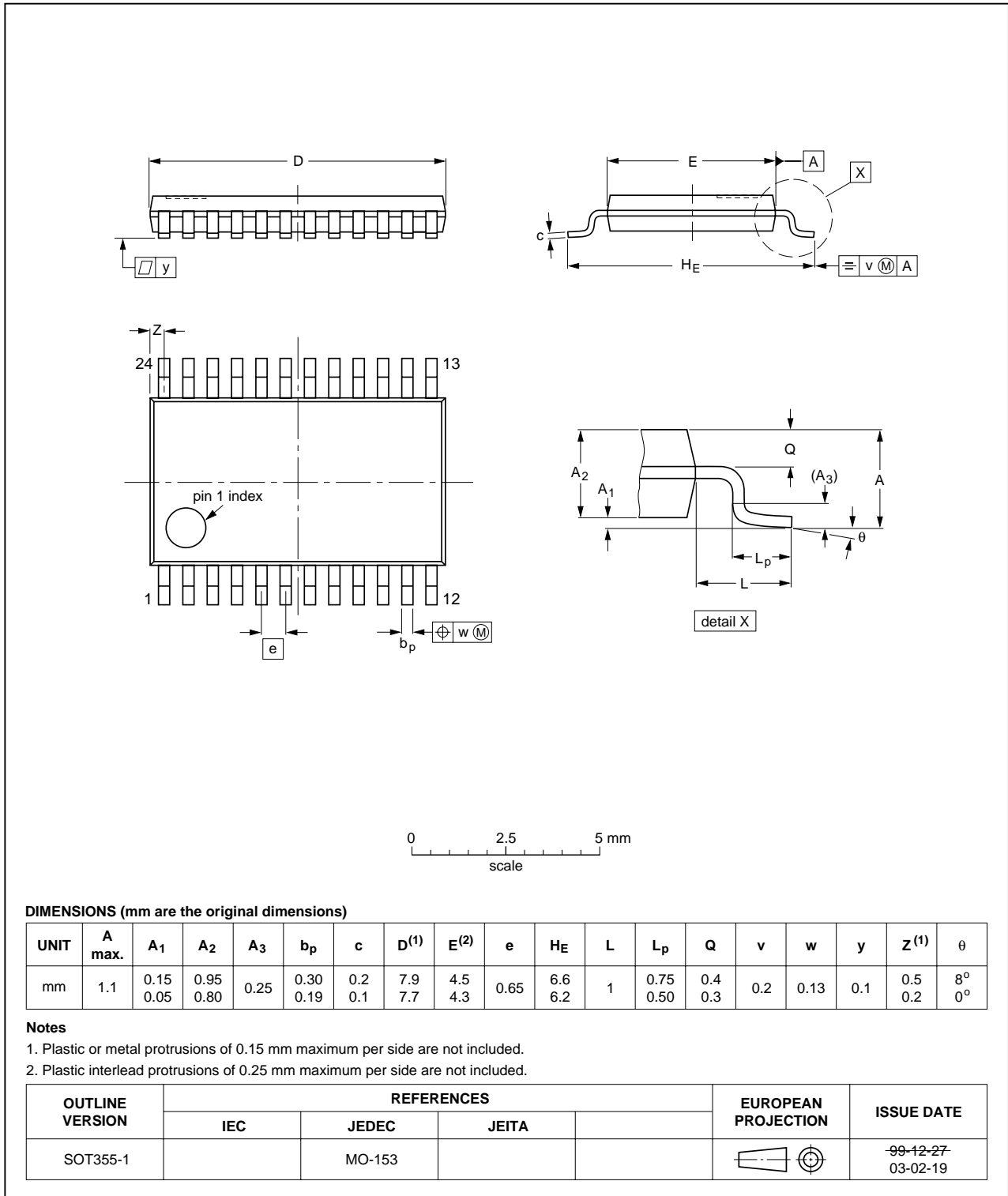

Fig 14. Package outline TSSOP24.

DHVQFN24: plastic dual in-line compatible thermal enhanced very thin quad flat package; no leads; 24 terminals; body 3.5 x 5.5 x 0.85 mm

SOT815-1

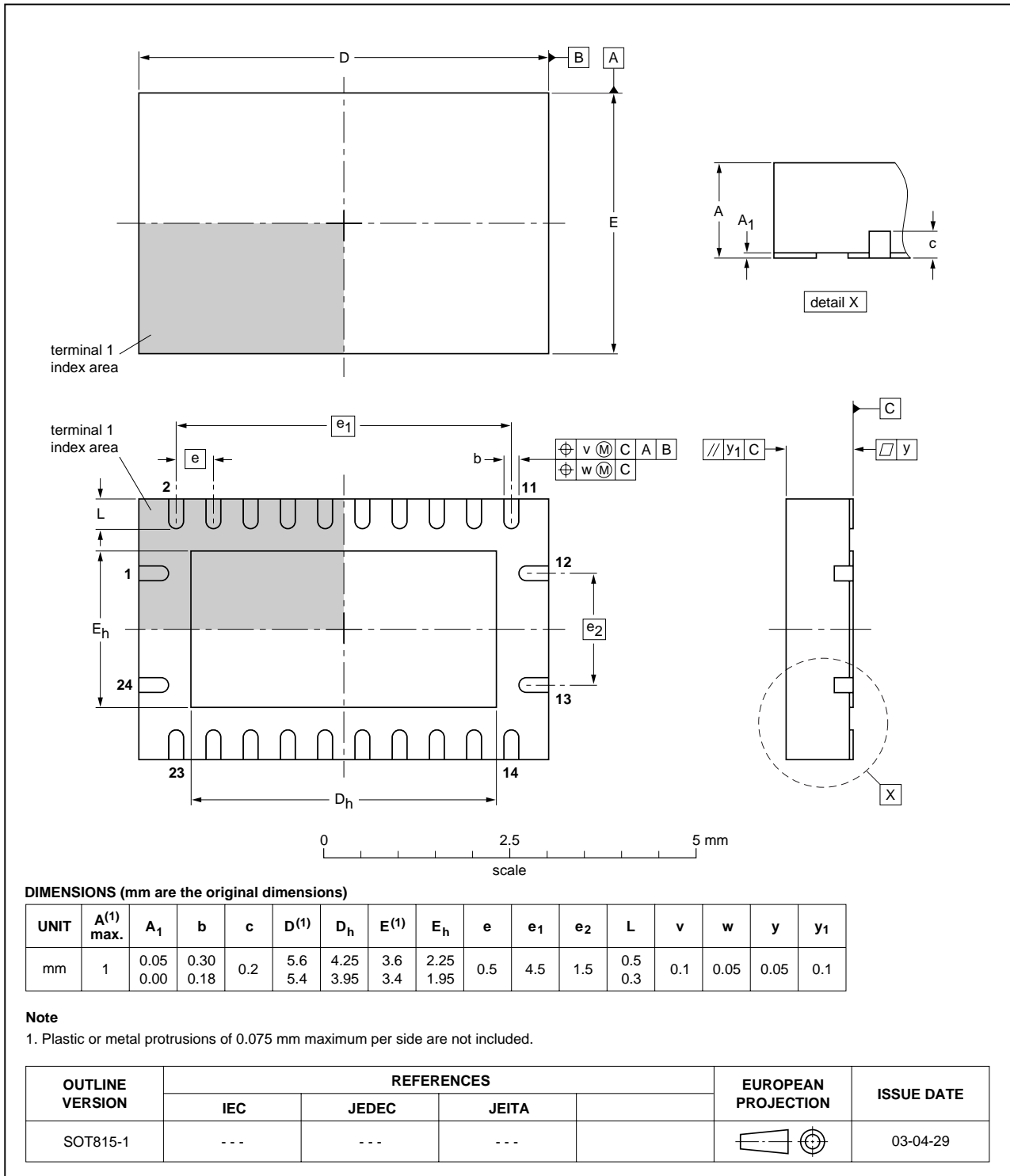

Fig 15. Package outline DHVQFN24.

14. Revision history

Table 10: Revision history

Document ID	Release date	Data sheet status	Change notice	Order number	Supersedes
74LVC841A_3	20040524	Product data	-	9397 750 13129	74LVC841A_2
Modifications:	<ul style="list-style-type: none">• The format of this data sheet has been redesigned to comply with the current presentation and information standard of Phillips Semiconductors.• Addition of temperature range $T_{amb} = -40\text{ °C}$ to $+125\text{ °C}$				
74LVC841A_2	19980617	Product specification	-	9397 750 04522	74LVC841A_1

15. Data sheet status

Level	Data sheet status ^[1]	Product status ^[2] ^[3]	Definition
I	Objective data	Development	This data sheet contains data from the objective specification for product development. Philips Semiconductors reserves the right to change the specification in any manner without notice.
II	Preliminary data	Qualification	This data sheet contains data from the preliminary specification. Supplementary data will be published at a later date. Philips Semiconductors reserves the right to change the specification without notice, in order to improve the design and supply the best possible product.
III	Product data	Production	This data sheet contains data from the product specification. Philips Semiconductors reserves the right to make changes at any time in order to improve the design, manufacturing and supply. Relevant changes will be communicated via a Customer Product/Process Change Notification (CPCN).

[1] Please consult the most recently issued data sheet before initiating or completing a design.

[2] The product status of the device(s) described in this data sheet may have changed since this data sheet was published. The latest information is available on the Internet at URL <http://www.semiconductors.philips.com>.

[3] For data sheets describing multiple type numbers, the highest-level product status determines the data sheet status.

16. Definitions

Short-form specification — The data in a short-form specification is extracted from a full data sheet with the same type number and title. For detailed information see the relevant data sheet or data handbook.

Limiting values definition — Limiting values given are in accordance with the Absolute Maximum Rating System (IEC 60134). Stress above one or more of the limiting values may cause permanent damage to the device. These are stress ratings only and operation of the device at these or at any other conditions above those given in the Characteristics sections of the specification is not implied. Exposure to limiting values for extended periods may affect device reliability.

Application information — Applications that are described herein for any of these products are for illustrative purposes only. Philips Semiconductors make no representation or warranty that such applications will be suitable for the specified use without further testing or modification.

17. Disclaimers

Life support — These products are not designed for use in life support appliances, devices, or systems where malfunction of these products can reasonably be expected to result in personal injury. Philips Semiconductors customers using or selling these products for use in such applications do so at their own risk and agree to fully indemnify Philips Semiconductors for any damages resulting from such application.

Right to make changes — Philips Semiconductors reserves the right to make changes in the products - including circuits, standard cells, and/or software - described or contained herein in order to improve design and/or performance. When the product is in full production (status 'Production'), relevant changes will be communicated via a Customer Product/Process Change Notification (CPCN). Philips Semiconductors assumes no responsibility or liability for the use of any of these products, conveys no license or title under any patent, copyright, or mask work right to these products, and makes no representations or warranties that these products are free from patent, copyright, or mask work right infringement, unless otherwise specified.

18. Contact information

For additional information, please visit: <http://www.semiconductors.philips.com>

For sales office addresses, send an email to: sales.addresses@www.semiconductors.philips.com

19. Contents

1	General description	1
2	Features	1
3	Quick reference data	2
4	Ordering information	2
5	Functional diagram	3
6	Pinning information	5
6.1	Pinning	5
6.2	Pin description	5
7	Functional description	6
7.1	Function table	6
8	Limiting values	6
9	Recommended operating conditions	7
10	Static characteristics	7
11	Dynamic characteristics	9
12	Waveforms	11
13	Package outline	15
14	Revision history	19
15	Data sheet status	20
16	Definitions	20
17	Disclaimers	20
18	Contact information	20



© Koninklijke Philips Electronics N.V. 2004

All rights are reserved. Reproduction in whole or in part is prohibited without the prior written consent of the copyright owner. The information presented in this document does not form part of any quotation or contract, is believed to be accurate and reliable and may be changed without notice. No liability will be accepted by the publisher for any consequence of its use. Publication thereof does not convey nor imply any license under patent- or other industrial or intellectual property rights.

Date of release: 24 May 2004
Document order number: 9397 750 13129

Published in The Netherlands