

Simple Packaged Crystal Oscillator (SPXO)

High stability
Ceramic Package
Wide Band Freq.

Pb-free : RoHs compliance

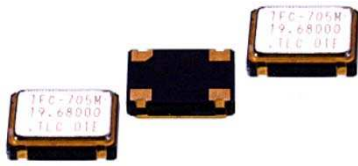

SP-7050CT

Typical applications

- PC board, VGA card, DVD, DVC, DSC, Printer Scanner.

Features

- 0.5 to 200 MHz.
- C-MOS out / 15pF(50pF) max Load, TTL out / (2TTL or 5TTL or 10TTL).
- Package : Metal lid + Ceramic package.
- 7.5×5.0×1.5mm

Specifications

Model	SP-7050CT3	SP-7050CT5
Available Frequency Range	0.50 to 200.000 MHz	0.50 to 107.000 MHz
Frequency Stability	±20 ppm/±25(0 to +70° C) , ±50 ppm,±100 ppm(-40 to +85° C)	
Operating Temperature	-20 to +70° C , -40 to +85° C	
Storage Temperature	-55 to +125° C	
Power Supply Voltage	3.3V±5%,	5.0V±5%,
Power Supply Current Consumption	10mA max: ~14.9MHz 15mA max: ~29.9MHz 20mA max: ~39.9MHz 25mA max: ~49.9MHz	30mA max: ~59.9MHz 35mA max: ~79.9MHz 45mA max: ~99.9MHz 50mA max: ~ 125MHz
Output	TTL-CMOS (See Table A)	
Tri state Function	#1 : N.C. or "H"→Output enable / #1 : "L"→Hi-Z(Output disable)	

Table A

Output	Level Load	CMOS	TTL (5.0V only)
		15 pF(50pF) max.	2TTL or 5TTL or 10TTL
Output Voltage		Vol:0.1V _{dd} max.,Voh:0.9V _{dd} min.	Vol:0.4V max.,Voh:2.4V min.
Rise & Fall Time		10ns max. at 10% to 90% V _{dd}	10ns max. at 0.4V to 2.4V
Duty Cycle		40 to 60% at 50% V _{dd}	40 to 60% at 1.4V

Environmental Characteristics

Description	Specification
Fall Shock	Test : 3 time free drop onto concrete board from 150cm high Result: ±5.0 ppm max.
Vibration Shock	Test : Freq. 5-500Hz, Amplitude 1.5mm, Test time 4cycles/XYZ axis Result: ±5.0 ppm max.
Solderability	Test : Immersed into solder bath at 235±° C for 3 sec. Result: More than 95%
Humidity	Test : 90 to 95%RH at 60±3° C±500 hours Result: ±5.0 ppm max.
Reflow Heat	Test : 2 times of IR reflow soldering in accordance with reflow temperature profile as per the document No.:TR-0531 Result: ±5.0 ppm max.

Outline Drawing & Suggested Pad

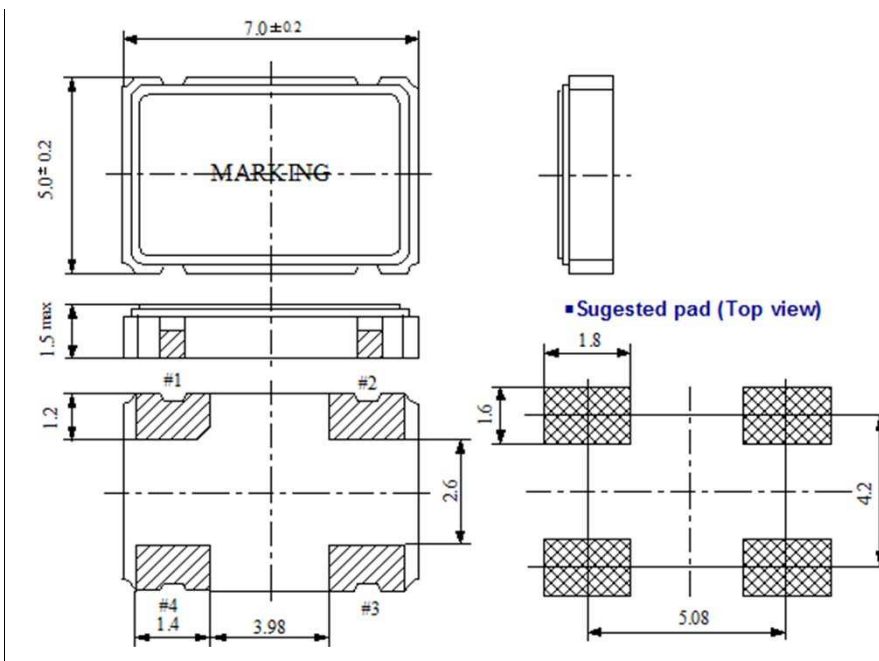

TERMINAL	CONNECTION
#1	0E/CE
#2	GND
#3	OUTPUT
#4	V _{dd}