

# Ceramic SMD Crystal Unit

Precision type  
Ceramic Package  
Miniature

Pb-free : RoHs compliance

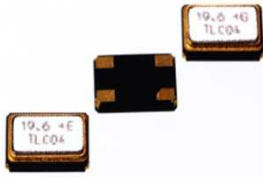

## TFC-5032M

### ■ Typical applications

- Pagers. PHS. Cordless Telephones. GPS. Bluetooth. Etc.

### ■ Features

- 10 to 120 MHz.
- Precision type Seam sealed units.
- Miniature type essential in the high density PCB.
- Package : Metal lid + Ceramic package.  
5.0×3.2×0.8mm

## ■ Specifications

Model	TFC - 5032M	
Frequency Range ( Fr )	8.000 to 50.000 MHz 45.000 to 120.000 MHz	Fundamental 3rd overtone
Frequency Tolerance (max) ( dF/F )	±10.0ppm to ±30.0ppm	at 25±3° C
Frequency Temperature Stability (max)	± 5.0ppm to ±30.0ppm (-10 to +60° C) ±10.0ppm to ±30.0ppm (-20 to +70° C) ±15.0ppm to ±30.0ppm (-30 to +85° C)	
Operating Temperature Range	-30 to +85° C	
Storage Temperature Range	-40 to +90° C	
Equivalent Series Resistance (max) ( Rr )	See below table	
Load Capacitance (typical) ( CL )	8.0pF to Series Resonance	
Parallel Capacitance (max) ( Co )	7.0pF max.	
Drive Level (typical) ( DL )	10.0μW to 500μW	

## ■ Environmental Characteristics

Description	Specification
Aging (at 25° C)	±1.0 ppm max / Year (at 25° C)
Fall Shock	Test : 3 time free drop onto concrete board from 150cm high Result: ±1.0 ppm max.
Vibration Shock	Test : Freq. 5-500Hz, Amplitude 1.5mm, Test time 4cycles/XYZ axis Result: ±1.0 ppm max.
Solderability	Test : Immersed into solder bath at 235±° C for 3 sec. Result: More than 95%
Humidity	Test : 90 to 95%RH at 60±3° C±500 hours Result: ±1.0 ppm max.
Reflow Heat	Test : 2 times of IR reflow soldering in accordance with reflow temperature profile as per the document No.:TR-0531 Result: ±1.0 ppm max.

## ■ Outline Drawing & Suggested Pad

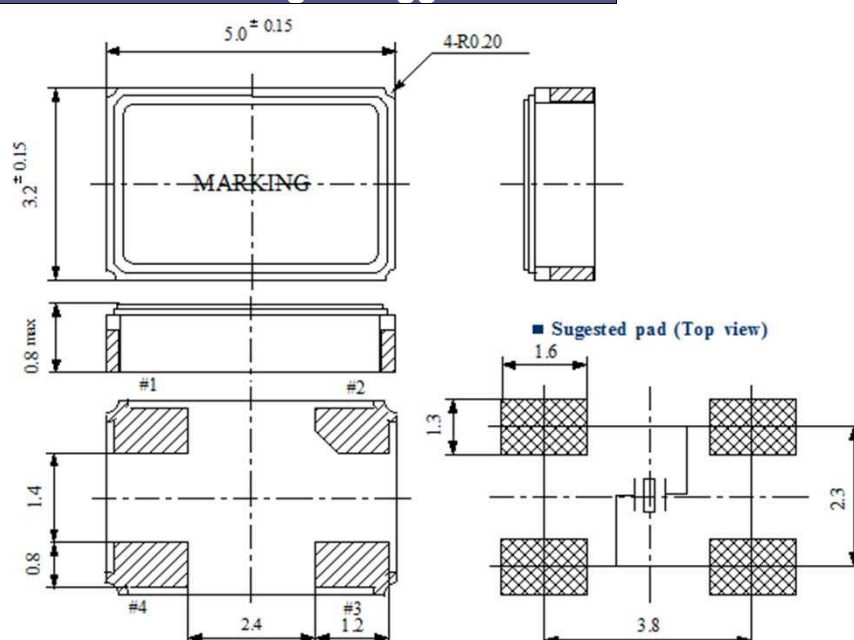

## ■ Equivalent Series Resistance

Freq. Range	Rr (max)	Mode
10.0 to 11.9MHz	40 Ω	Fundamental
12.0 to 14.9MHz	35 Ω	
15.0 to 19.9MHz	30 Ω	
20.0 to 50.0MHz	20 Ω	
45.0 to 59.9MHz	55 Ω	3rd overtone
60.0 to 89.9MHz	50 Ω	
90.0 to 120MHz	45 Ω	

### Connection

- #1 Input
- #2 NC
- #3 Output
- #4 Ground