

Ceramic SMD Crystal Unit

Precision type
Ceramic Package
Miniature

Pb-free : RoHs compliance

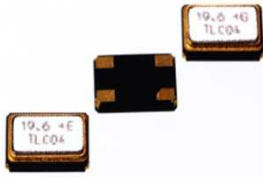

TFC-4025M

■ Typical applications

- Pagers. PHS. Cordless Telephones. GPS. Bluetooth. Etc.

■ Features

- 12 to 50 MHz.
- Precision type Seam sealed units.
- Miniature type essential in the high density PCB.
- Package : Metal lid + Ceramic package.
4.0×2.5×0.8mm

■ Specifications

Model	TFC - 4025M	
Frequency Range (Fr)	12.000 to 50.000 MHz	Fundamental
Frequency Tolerance (max) (dF/F)	±10.0ppm to ±30.0ppm	at 25±3° C
Frequency Temperature Stability (max)	± 5.0ppm to ±30.0ppm (-10 to +55° C) ±10.0ppm to ±30.0ppm (-20 to +70° C) ±15.0ppm to ±30.0ppm (-30 to +85° C)	
Operating Temperature Range	-30 to +85° C	
Storage Temperature Range	-40 to +90° C	
Equivalent Series Resistance (max) (Rr)	See below table	
Load Capacitance (typical) (CL)	8.0pF to Series Resonance	
Parallel Capacitance (max) (Co)	7.0pF max.	
Drive Level (typical) (DL)	10.0μW to 500μW	

■ Environmental Characteristics

Description	Specification
Aging (at 25° C)	±1.0 ppm max / Year (at 25° C)
Fall Shock	Test : 3 time free drop onto concrete board from 150cm high Result: ±1.0 ppm max.
Vibration Shock	Test : Freq. 5-500Hz, Amplitude 1.5mm, Test time 4cycles/XYZ axis Result: ±1.0 ppm max.
Solderability	Test : Immersed into solder bath at 235±° C for 3 sec. Result: More than 95%
Humidity	Test : 90 to 95%RH at 60±3° C±500 hours Result: ±1.0 ppm max.
Reflow Heat	Test : 2 times of IR reflow soldering in accordance with reflow temperature profile as per the document No.:TR-0531 Result: ±1.0 ppm max.

■ Outline Drawing & Suggested Pad

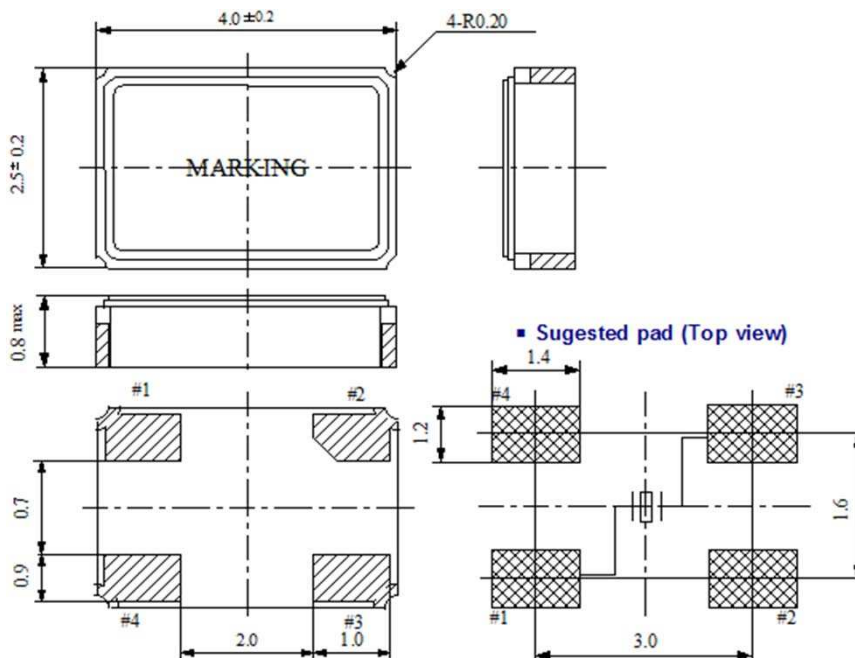

■ Equivalent Series Resistance

Freq. Range	Rr (max)	Mode
12.0 to 15.9MHz	90 Ω	Fundamental
16.0 to 25.9MHz	80 Ω	
26.0 to 31.9MHz	60 Ω	
32.0 to 50.0MHz	50 Ω	

Connection

- #1 Input
- #2 NC
- #3 Output
- #4 Ground