

# DATA SHEET

For a complete data sheet, please also download:

- The IC06 74HC/HCT/HCU/HCMOS Logic Family Specifications
- The IC06 74HC/HCT/HCU/HCMOS Logic Package Information
- The IC06 74HC/HCT/HCU/HCMOS Logic Package Outlines

## **74HC7266**

Quad 2-input **EXCLUSIVE-NOR**  
gate

Product specification  
File under Integrated Circuits, IC06

December 1990

## Quad 2-input EXCLUSIVE-NOR gate

## 74HC7266

### FEATURES

- Output capability: standard
- $I_{CC}$  category: SSI

### GENERAL DESCRIPTION

The 74HC7266 are high-speed Si-gate CMOS devices and are pin compatible with low power Schottky TTL (LSTTL). They are specified in compliance with JEDEC standard no. 7A.

The 74HC7266 provide the EXCLUSIVE-NOR function with active push-pull output.

### QUICK REFERENCE DATA

GND = 0 V;  $T_{amb} = 25\text{ }^{\circ}\text{C}$ ;  $t_r = t_f = 6\text{ ns}$

SYMBOL	PARAMETER	CONDITIONS	TYPICAL	UNIT
			HC	
$t_{PHL}/t_{PLH}$	propagation delay nA, nB to nY	$C_L = 15\text{ pF}$ ; $V_{CC} = 5\text{ V}$	11	ns
$C_I$	input capacitance		3.5	pF
$C_{PD}$	power dissipation capacitance per gate	note 1	17	pF

### Notes

1.  $C_{PD}$  is used to determine the dynamic power dissipation ( $P_D$  in  $\mu\text{W}$ ):

$$P_D = C_{PD} \times V_{CC}^2 \times f_i + \sum (C_L \times V_{CC}^2 \times f_o) \text{ where:}$$

$f_i$  = input frequency in MHz

$f_o$  = output frequency in MHz

$C_L$  = output load capacitance in pF

$V_{CC}$  = supply voltage in V

$\sum (C_L \times V_{CC}^2 \times f_o)$  = sum of outputs

2. For HC the condition is  $V_I = \text{GND to } V_{CC}$   
For HCT the condition is  $V_I = \text{GND to } V_{CC} - 1.5\text{ V}$

### ORDERING INFORMATION

See *"74HC/HCT/HCU/HCMOS Logic Package Information"*.

Quad 2-input EXCLUSIVE-NOR gate

74HC7266

PIN DESCRIPTION

PIN NO.	SYMBOL	NAME AND FUNCTION
1, 5, 8, 12	1A to 4A	data inputs
2, 6, 9, 13	1B to 4B	data inputs
3, 4, 10, 11	1Y to 4Y	data outputs
7	GND	ground (0 V)
14	V <sub>CC</sub>	positive supply voltage

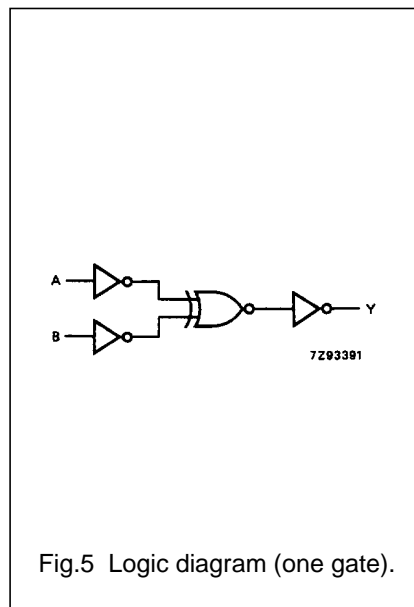
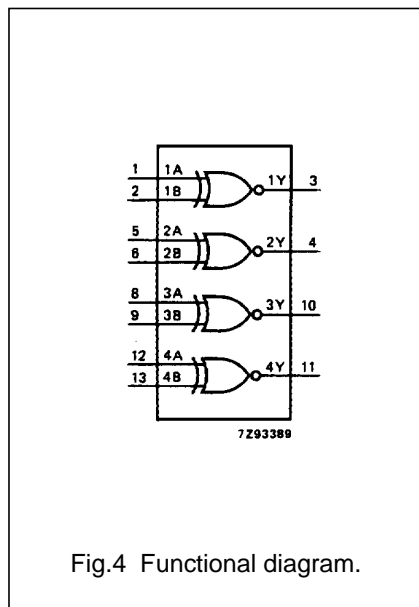
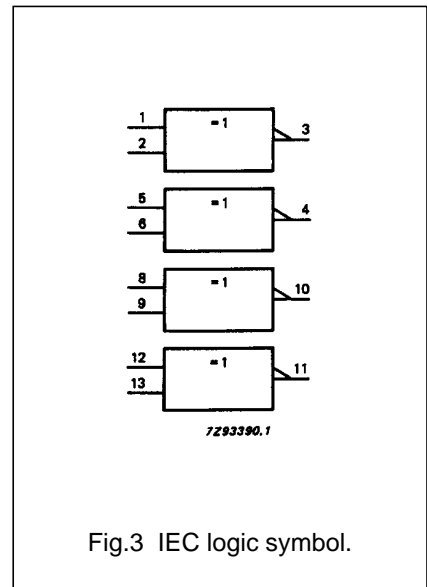
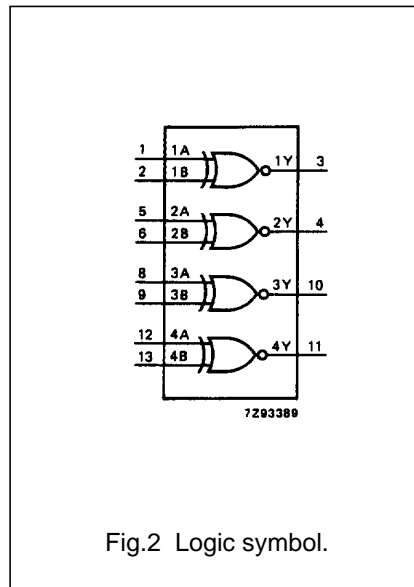
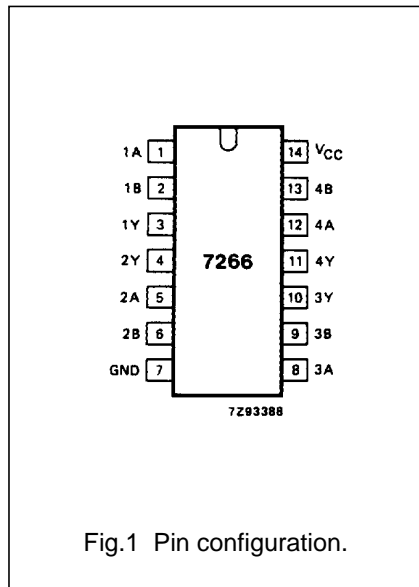

FUNCTION TABLE

INPUTS		OUTPUT
nA	nB	nY
L	L	H
L	H	L
H	L	L
H	H	H

Notes

- H = HIGH voltage level  
L = LOW voltage level

Quad 2-input EXCLUSIVE-NOR gate

74HC7266

**DC CHARACTERISTICS FOR 74HC**

For the DC characteristics see *"74HC/HCT/HCU/HCMOS Logic Family Specifications"*.

Output capability: standard

I<sub>CC</sub> category: SSI

**AC CHARACTERISTICS FOR 74HC**

GND = 0 V; t<sub>r</sub> = t<sub>f</sub> = 6 ns; C<sub>L</sub> = 50 pF

SYMBOL	PARAMETER	T <sub>amb</sub> (°C)						UNIT	TEST CONDITIONS		
		74HC							V <sub>CC</sub> (V)	WAVEFORMS	
		+25			-40 to +85		-40 to +125				
		min.	typ.	max.	min.	max.	min.				max.
t <sub>PHL</sub> / t <sub>PLH</sub>	propagation delay nA, nB to nY		39 14 11	115 23 20		145 29 25		175 35 30	ns	2.0 4.5 6.0	Fig.6
t <sub>THL</sub> / t <sub>TLH</sub>	output transition time		19 7 6	75 15 13		95 19 16		110 22 19	ns	2.0 4.5 6.0	Fig.6

**AC WAVEFORMS**

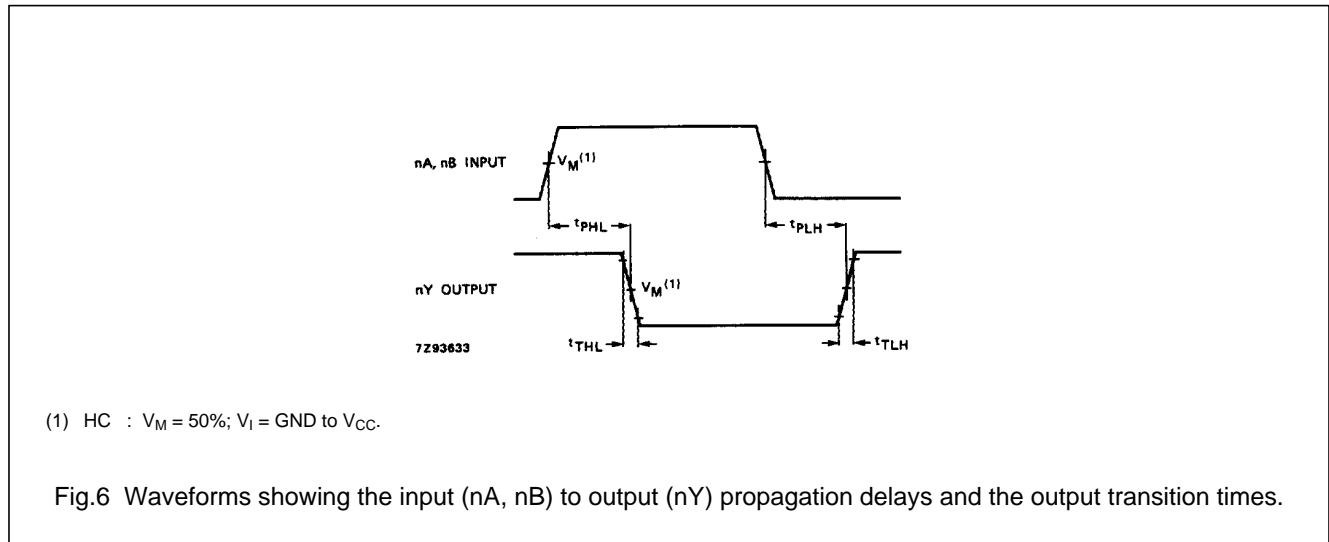

**PACKAGE OUTLINES**

See *"74HC/HCT/HCU/HCMOS Logic Package Outlines"*.