

Part Number PRX+9200 Contact Form B Switch Configuration SPST Rev. E

### High Power Proximity Sensor

Features	Advantages
<ul style="list-style-type: none"> <li>Hermetically sealed contacts</li> <li>Jacketed cable</li> <li>Black ABS housing</li> </ul>	<ul style="list-style-type: none"> <li>Extended operations in extreme environments</li> <li>Not ESD sensitive</li> <li>Custom sensitivity and configurations available</li> <li>Housing material flame rating: UL94</li> </ul>

### Electrical Specifications

Power		Watts - maximum	25
Voltage	Switching	VDC - maximum	150
	Breakdown	VDC - minimum	300
Current	Switching	Amp - maximum	1
	Carry	Amp - maximum	5.6
Resistance	Initial Contact Resistance	Ohm - maximum	0.3
	Insulation Resistance	Ohm - minimum	1 E9
Capacitance	Contact	pF - typical	2.2
Temperature	Operating	°C - maximum	+80
	Storage	°C	-40 to +105

### Physical/Operational Specifications

Housing Volume	Excluding Connection	CC - nominal	18.6
External Connection	22 AWG	UL 2464	PVC
Must Operate	Distance (d)	Inches	0.750
Must Release	Distance (d)	Inches	1.500
Operate Time	Including Bounce	mSeconds - maximum	2.7
Release Time		mSeconds - maximum	4.5

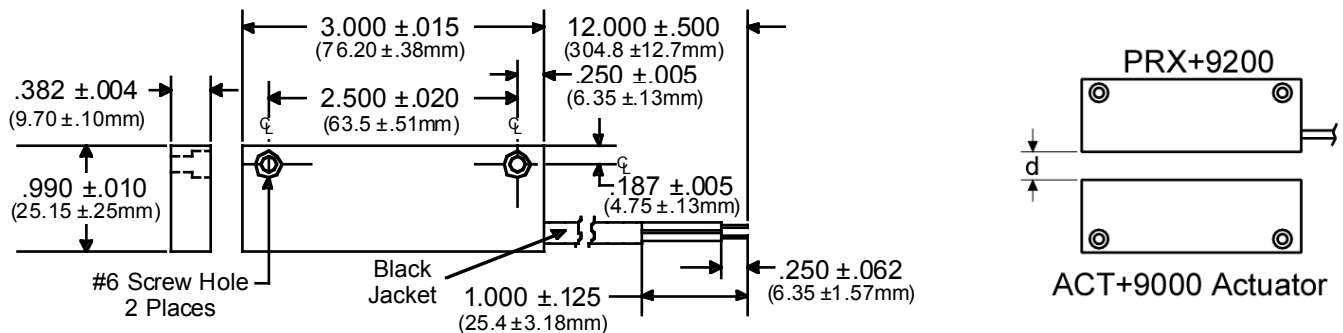

- Notes:
- Specifications are not constant across entire magnetic range.
  - Customer must exercise care in handling and mounting to prevent damage to internal components and subsequent changes to sensor performance.
  - For information about performance, custom configuration (i.e. wire length or color; connectors; operational variation), or packaging contact our Sales department.
  - Information contained hereon is for informational purposes only and should not be deemed as accurate for a specific application. Consult factory for specific application information and/or latest revision.