

Part Number PRX+9250 Contact Form B Switch Configuration SPST Rev. E

High Power Proximity Sensor

Features	Advantages
<ul style="list-style-type: none"> Hermetically sealed contacts Black ABS housing Jacketed cable Tungsten contacts 	<ul style="list-style-type: none"> Extended operations in extreme environments Not ESD sensitive Custom sensitivity and configurations available High power switching capability Housing material flame rating: UL94

Electrical Specifications

Power		Watts - maximum	100
Voltage	Switching	VDC - maximum	300
	Breakdown	VDC - minimum	300
Current	Switching	Amp - maximum	3
	Carry	Amp - maximum	TBD
Resistance	Initial Contact Resistance	Ohm - maximum	0.7
	Insulation Resistance	Ohm - minimum	1E10
Capacitance	Contact	pF - typical	3
Temperature	Operating	°C - maximum	+80
	Storage	°C	-100 to +105

Physical/Operational Specifications

Housing Volume	Excluding Connection	CC - nominal	18.6
External Connection	22 AWG	UL 2464	PVC
Must Operate	Distance (d)	Inches	0.500
Must Release	Distance (d)	Inches	1.500
Operate Time	Including Bounce	mSeconds - maximum	4.2
Release Time		mSeconds - maximum	3.7

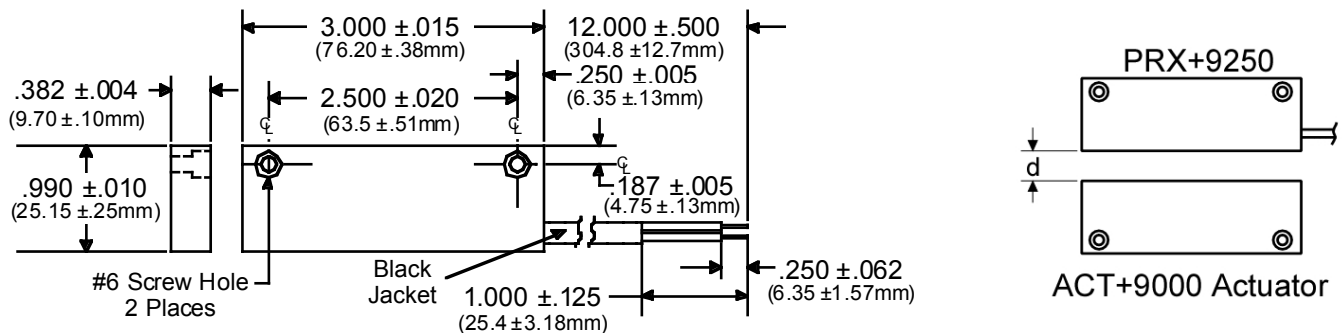

- Notes:
- (1) Specifications are not constant across entire magnetic range.
 - (2) Customer must exercise care in handling and mounting to prevent damage to internal components and subsequent changes to sensor performance.
 - (3) For information about performance, custom configuration (i.e. wire length or color; connectors; operational variation), or packaging contact our Sales department.
 - (4) Information contained hereon is for informational purposes only and should not be deemed as accurate for a specific application. Consult factory for specific application information and/or latest revision.