

Part Number PRX+5300 Contact Form C Switch Configuration SPDT Rev. E

### Lug-Type Proximity Sensor for Industrial/Alarm Applications

Features	Advantages
<ul style="list-style-type: none"> <li>Hermetically sealed contacts</li> <li>Housing color eggshell</li> <li>Housing color brown, PRX+5302</li> </ul>	<ul style="list-style-type: none"> <li>Extended Operations in extreme environments</li> <li>Not ESD sensitive</li> <li>Custom sensitivity and configurations available</li> <li>UL Listed</li> </ul>

### Electrical Specifications

Power		Watts - maximum	3
Voltage	Switching	VDC - maximum	120
	Breakdown	VDC - minimum	400
Current	Switching	Amp - maximum	0.25
	Carry	Amp - maximum	2.6
Resistance	Initial Contact Resistance	Ohm - maximum	0.25
	Insulation Resistance	Ohm - minimum	1 E9
Capacitance	Contact	pF - typical	1.7
Temperature	Operating	°C - maximum	+10 to +70
	Storage	°C	+10 to +70

### Physical/Operational Specifications

Housing Volume	Excluding Connection	CC - nominal	13.6
External Connection		Lug Terminal	Tin
Must Operate	Distance (d)	Inches	1.000
Must Release	Distance (d)	Inches	2.500
Operate Time	Including Bounce	mSeconds - maximum	1
Release Time		mSeconds - maximum	0.8

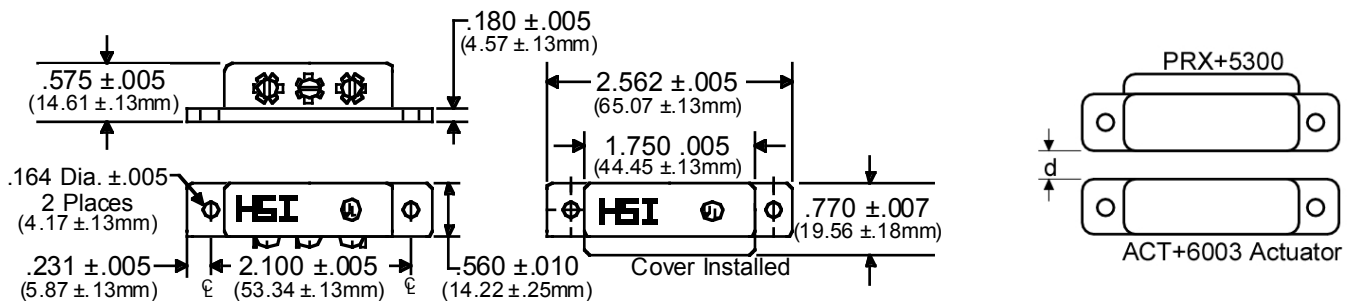

- Notes:
- (1) Specifications are not constant across entire magnetic range.
  - (2) Customer must exercise care in handling and mounting to prevent damage to internal components and subsequent changes to sensor performance.
  - (3) For information about performance, custom configuration (i.e. wire length or color; connectors; operational variation), or packaging contact our Sales department.
  - (4) Information contained hereon is for informational purposes only and should not be deemed as accurate for a specific application. Consult factory for specific application information and/or latest revision.