



PXS series - 15W Dual High Reliability DC-DC Converters

Outline Product Specification

FEATURES

- High reliability / small size
- In photoelectric isolation
- Input voltage range: 16V_{DC} to 40V_{DC}
- Output power: 15W
- Inhibit and synchronization functions
- Over current / short circuit protection
- DIP hermetical



The PXS series dual output series module, which adopts Thick-Film Microcircuit Technology, stannic seam welding process, is a kind of perfect converter with high reliability necessary for some applications such as industry and military.

The output voltages are ±12V or ±15V. The output power is 15W. The switching frequency is fixed at 265 KHz to minimize noise. The input filter circuit is designed to reduce the electro-magnetic interference.

The typical input voltage is 28V, and the ranges from 16V to 40V. The PXS series also provides some control functions such as synchronization, shut down, and over-current and short circuit protection.

MECHANICAL SPECIFICATIONS

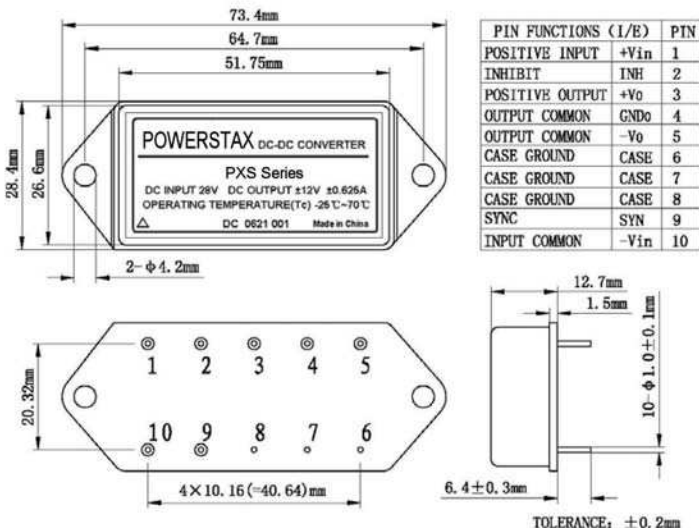

ABSOLUTE MAXIMUM RATINGS

- Input Voltage: +16V_{DC} to +40V_{DC}
- Pin-Solder Temp (10s): 300°C
- Storage Temp: -55°C to +125°C
- Output Power: 15W
- Operating Temp (T_c): -40°C to +75°C



BLOCK DIAGRAM

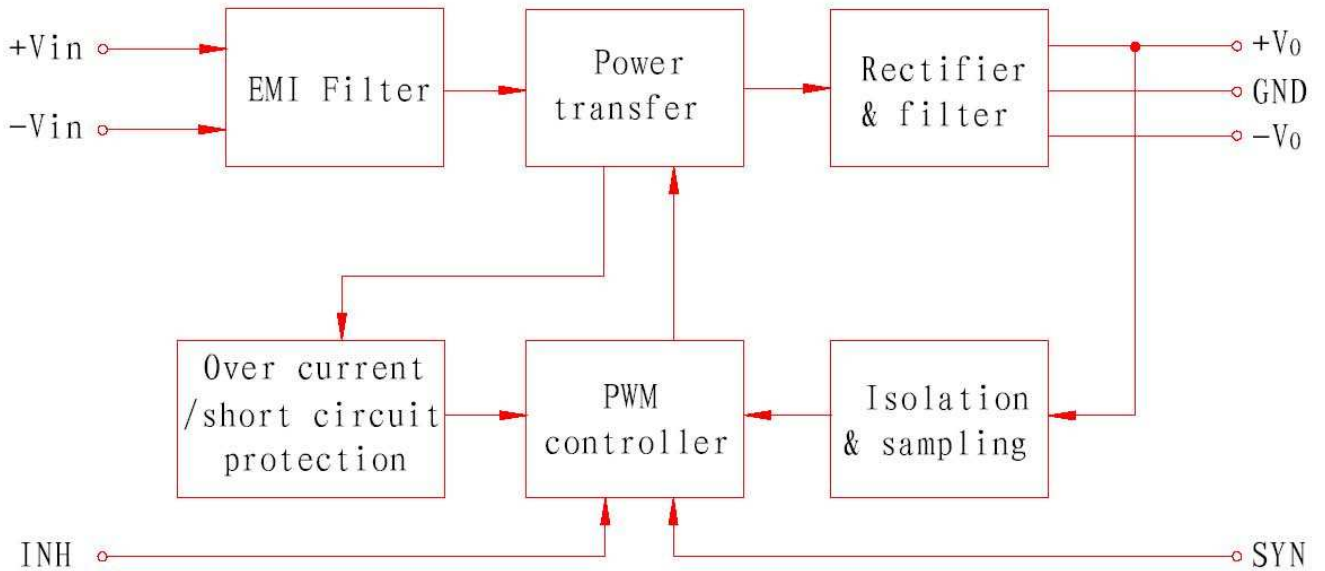



ELECTRICAL CHARACTERISTICS

PARAMETER	CONDITION ⁵	PXS-2812D-15			PXS-2815D-15			UNITS
		MIN	TYP	MAX	MIN	TYP	MAX	
OUTPUT VOLTAGE	V _{IN} =16V _{DC} to 40V _{DC} +V _o	11.88	12.00	12.12	14.85	15.00	15.15	V
	-V _o	11.82	12.00	12.18	14.77	15.00	15.23	
OUTPUT CURRENT	V _{IN} =28V _{DC} ±I _o	0	—	0.625	0	—	0.5	A
OUTPUT POWER	V _{IN} =28V _{DC}	0	—	15	0	—	15	W
OUTPUT RIPPLE VOLTAGE ¹	V _{IN} =28V, FULL LOAD, 20MHz	—	30	80	—	25	80	mVpp
	MIN to MAX T _c	—	40	120	—	40	120	
LINE REGULATION	V _{IN} =16V _{DC} to 40V _{DC}	—	10	50	—	10	50	mV
	T _c MIN to MAX	—	50	150	—	50	180	
LOAD REGULATION	I _o =0 to 100%	—	15	50	—	15	50	mV
	T _c MIN to MAX	—	30	150	—	30	180	
CROSS REGULATION	20% to 80% ²	—	4	8.3	—	3	8	%
	10% to 50% ³	—	4	6	—	4	6	
INPUT VOLTAGE	CONTINUOUS	16	28	40	16	28	40	V _{DC}
	TRANSIENT 50ms	0	—	50	0	—	50	
INPUT CURRENT	NO LOAD	—	50	75	—	50	75	mA
	FULL LOAD	—	0.88	—	—	0.86	—	A
	INHIBITED	—	7	8	—	7	8	mA
INPUT RIPPLE CURRENT	V _{IN} =28V, FULL LOAD, 20MHz	—	20	50	—	20	50	mApp
EFFICIENCY		79	81	—	80	83	—	%
LOAD FAULT SHORT CIRCUIT TO FULL LOAD	SHORT CIRCUIT POWER DISSIPATION	—	—	12	—	—	12	W
	RECOVERY ⁴	—	1.4	5.0	—	1.4	5.0	ms
STEP LOAD RESPONSE. TRANSIENT	50% to 100% to 50%	—	±150	±300	—	±200	±400	mV
STEP LOAD RESPONSE. TRANSIENT RECOVERY		—	100	200	—	100	200	us
STEP LINE RESPONSE.	OVERSHOOT	—	±200	±400	—	±400	±500	mV
	RECOVERY ⁴	—	—	300	—	—	300	µs
START-UP	DELAY	—	1.4	5	—	1.4	5	ms
	FULL LOAD OVERSHOOT	—	0	120	—	0	150	mVpk
	NO LOAD OVERSHOOT	—	120	600	—	150	750	
Insulation Resistance	≥100MΩ@500VDC (input to output, any pins to case)							

NOTE:

- Using tip and barrel measurement.
- +Pout 20%• ~80%; ~Pout 80%• ~20%.
- +Pout 50%; ~Pout 10%• ~50%.
- Recovery time is measured from application of the transient to the point at which Vout is within 1% of final value.
- T_c =25°C, Vin =28VDC, 100% load, unless otherwise specified.

Performance Characteristics

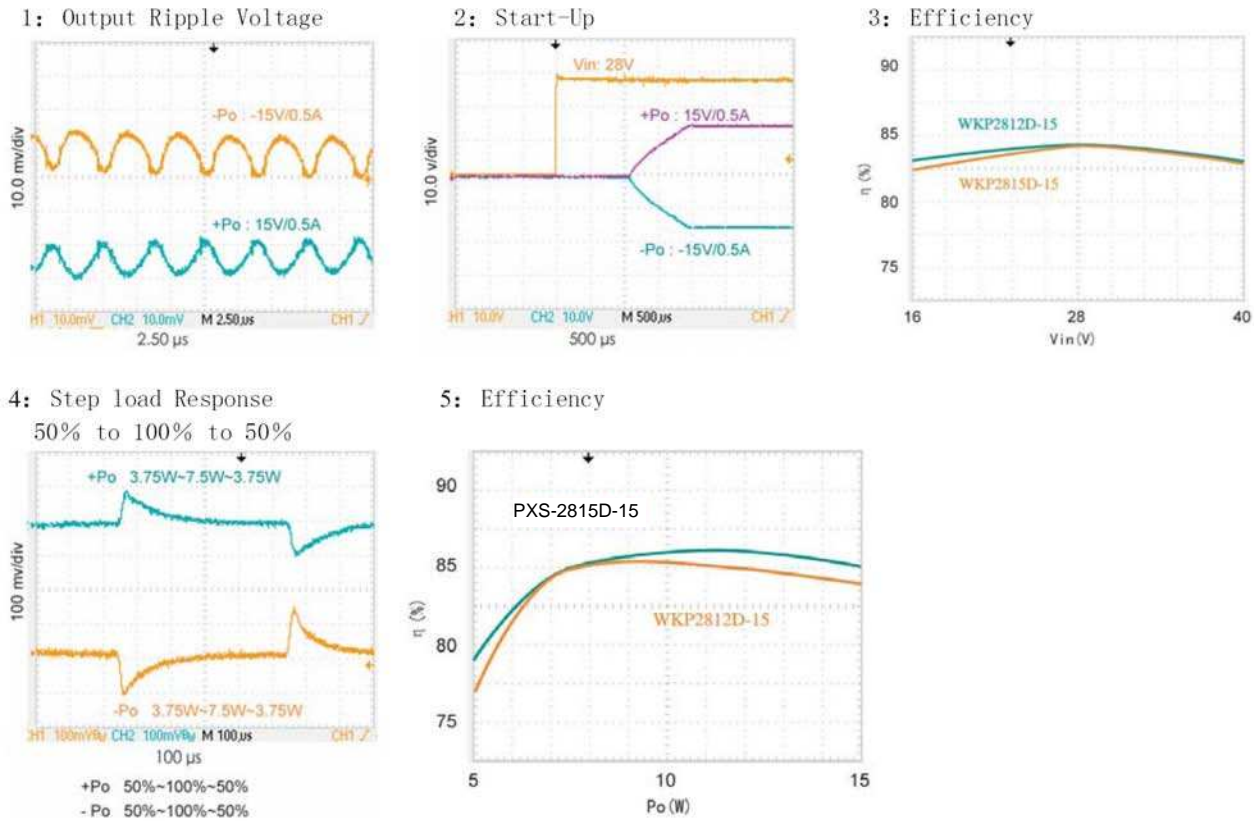

APPLICATION NOTE

INHIBIT FUNCTION

The INH pin is used to achieve the function of external shut down. No connection to Pin 2 is necessary for normal operation of the converter. Shut down may be implemented by simply pulling the Pin 2 below 0.3V referenced to input common.

Over Current/Short Circuit Protection

The PXS-15 series of DC/DC converters has the function of over current/short circuit protection. When it is working under load fault condition, the converter will automatically activate the over current/short circuit protection and restore when the fault is removed. It is suggested that the duration of the over current/short circuit must be less than 10s, and the case temperature lower than 105°C, Otherwise, the module will be disabled.

Ripple Voltage

While the output V-ripple can't satisfy your application, it can still be suppressed by adding a filter capacitor between V_{o+} and V_{o-} outputs. The optimal value for this capacitor is recommended at around 50V/ 10 μF with film or ceramic capacitor as preferable options.



Block Diagram

Synchronisation

The PXS-15 series of DC/DC converters allow the designer to match the switching frequency of the converter to the frequency of the system clock or synchronize several modules by synchronization pin. Frequency ranges from 270 to 350 KHz, the level from -0.3 to 10V, and duty cycle from 40% to 60%. Under master and slave configuration, the master module will offer $\pm 3\text{mA}$ current and the slave ones $\pm 0.5\text{mA}$ in maximum. A connection to pin 9 is not necessary for not in use.

Reverse Polarity Protection:

To avoid the input reverse connection, it's advised to connect a diode in series with the input pin of the converter. (Shown as below)

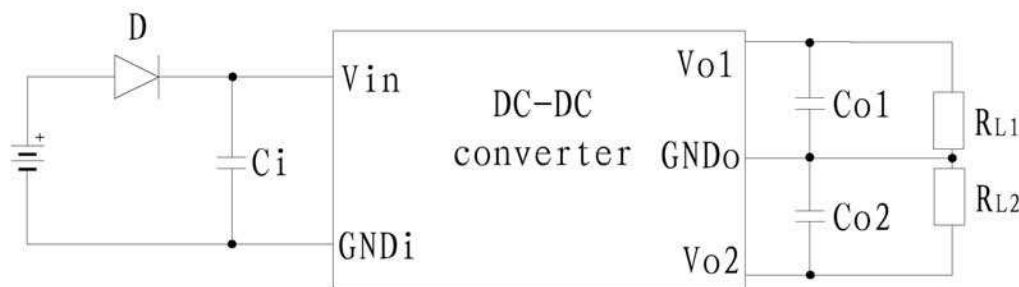

ORDERING INFORMATION:

PX S 28 12 D - 15 I

Grade: E=High reliability; I=Industrial
 Output Power: 15=15W
 Number of Output: D=Dual
 Output Voltage: 12= $\pm 12\text{V}$
 Input Voltage: 28=28V
 P=Stannic seam welding process
 Model

Mark specification

Serials Number: DC 0621 001, which indicates this product has been manufactured in the 21st week of 2006, and the sequence number is 001.

Environmental Screening

Test item	Method	Condition	E	I
PRE-CAP Inspection	MIL-STD-883 Method 2017	---	Y	Y
Temp-Cycle	MIL-STD-883 Method 1010	-55°C to +125°C, 10 times	Y	---
Constant Acceleration	MIL-STD-883 Method 2001	500 g, Y1, 1min	Y	---
Burn-in	MIL-STD-883 Method 1015	+85°C, 96h	Y	---
		+85°C, 48h	---	Y
Final Electrical Test	MIL-PRF-38534	+25°C	Y	Y
		+85°C	Y	---
		-40°C	Y	---
Final Visual Inspection	MIL-STD-883 Method 2009	---	Y	Y

Exceeding absolute maximum ratings may cause permanent damage and may reduce reliability. Information and specifications contained in this data sheet are believed to be correct at the time of publication. However, Powerstax accept no responsibility for consequences arising from printing errors or inaccuracies. Specifications are subject to change without notice.

