



POWERSTAX ref: PX302851*T-15 Series DC-DC Converters

FEATURES:

- High reliability, compact size
- Photoelectric isolation
- Input voltage range: 16VDC to 40VDC
- Output power: 15W
- Inhibit function
- Short circuit protection
- DIP hermetical

DESCRIPTION:

The PX302851*T-15 series modules, which adopt Thick-Film Microcircuit Technology, parallel seam welding process, are perfect converters with high reliability necessary for some applications such as aviation, aerospace and military. The output voltages are 5V and $\pm 12V$ or 15V. The output power is 15W. The switching frequency is fixed at 430 kHz to minimize noise. The input filter circuit is designed to reduce the electro-magnetic interference. The typical input voltage is 28V, and ranges from 16V to 40V. The PX302851*T-15 series also provide some control functions such as shut down and short circuit protection.

BLOCK DIAGRAM:

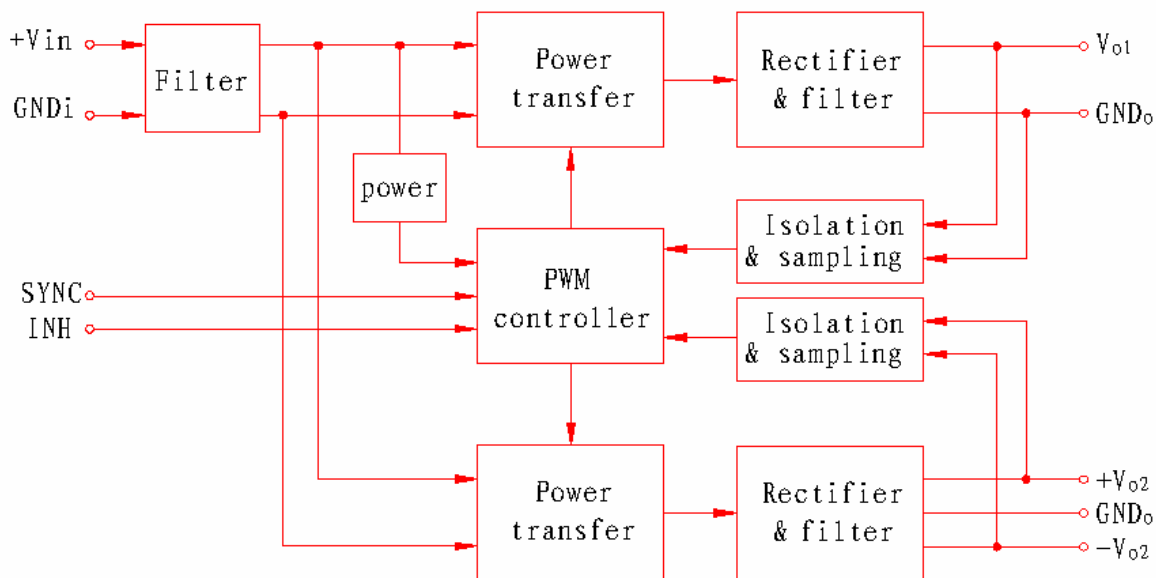

ABSOLUTE MAXIMUM RATINGS:

Output Power:	15W
Operating Temp (TC):	-55°C ~ 105°C (M) / -40°C ~ 85°C (E/I)
Storage Temp:	-55°C ~ 125°C (M/ E/I)
Pin-Solder Temp (10s):	300°C



POWERSTAX ref: PX302851*T-15 Series DC-DC Converters

THE ELECTRICAL CHARACTERISTICS:

Parameter	Conditions ¹	PX3028512T-15			PX3028515T-15			Units		
		Min	Typ	Max	Min	Typ	Max			
Output Voltage	$V_{IN} = 28V_{DC}$	+5V	4.90	5.00	5.10	4.90	5.00	5.10	V_{DC}	
		$\pm V_o$	11.82	12.00	12.18	14.78	15.00	15.22		
	MIN ~ MAX T_c	+5V	4.84	5.00	5.16	4.84	5.00	5.16		
		$\pm V_o$	11.67	12.00	12.33	14.60	15.00	15.40		
Output Current	$V_{IN} = 16V_{DC} \sim 40V_{DC}$	+5V	-	-	1.5	-	-	1.5	A	
		$\pm V_o$	-	-	0.32	-	-	0.25		
Output Power	$V_{IN} = 28V_{DC}$	+5V	-	-	7.5	-	-	7.5	W	
		$\pm V_o$	-	-	7.5	-	-	7.5		
Output Ripple Voltage ²	$V_{IN}=28V_{DC}$ FULL LOAD 20MHz	+5V	-	30	50	-	30	50	mV_{P-P}	
		$\pm V_o$	-	30	80	-	30	80		
	MIN ~ MAX T_c	+5V	-	50	100	-	50	100		
		$\pm V_o$	-	50	100	-	50	100		
Line Regulation	$V_{IN} = 16V_{DC} \sim 40V_{DC}$	+5V	-	20	30	-	20	30	mV	
		$\pm V_o$	-	20	30	-	20	30		
	MIN ~ MAX T_c	+5V	-	20	50	-	20	50		
		$\pm V_o$	-	20	50	-	20	50		
Load Regulation	$V_{IN}=28V_{DC}$ NO ~ FULL LOAD	+5V	-	20	30	-	20	30	mV	
		$\pm V_o$	-	20	30	-	20	30		
	MIN ~ MAX T_c	+5V	-	20	50	-	20	50		
		$\pm V_o$	-	20	50	-	20	50		
Cross Regulation	20% - 80%	$\pm V_o$	-	2	3	-	2	3	%	
	10% - 50%	$\pm V_o$	-	2	3	-	2	3		
Input Voltage	CONTINUOUS		16	28	40	16	28	40	V	
	50V/50ms		-	-	50	-	-	50		
Input Current	NO LOAD		-	50	80	-	50	80	mA	
	FULL LOAD		-	678	715	-	678	715		
	INHIBITED		-	10	20	-	10	20		
			-	10	20	-	10	20		
Efficiency	$V_{in}=28V_{DC}$ FULL LOAD		75	79	-	75	79	-	%	
Short Circuit Power Dissipation	$V_{IN}=28V_{DC}$		-	3	5	-	3	5	W	
Step Load Response Transient	$V_{in}=28V_{DC}$	+5V	-	200	300	-	200	300	mV	
		$\pm V_o$	-	200	300	-	200	300		
Step Load Response Transient Recovery ³	50%~100%~50%	+5V	-	200	300	-	200	300	μs	
		$\pm V_o$	-	200	300	-	200	300		
Start-Up	DELAY		-	-	10	20	-	10	20	Ms
	FULL LOAD OVERSHOOT	$V_{in}=28V_{DC}$ FULL LOAD	+5V	-	50	100	-	50	100	mV
			$\pm V_o$	-	50	100	-	50	100	
Maximum Admissible Capacity Load	$V_{in}=28V_{DC}$ FULL LOAD	+5V	-	-	1000	-	-	1000	μF	
		$\pm V_o$	-	-	220	-	-	220		
Insulation Resistance ⁴	$\geq 100M\Omega @ 500V_{DC}$ (INPUT – OUTPUT; ANY PINS TO CASE)									



POWERSTAX ref: PX302851*T-15 Series DC-DC Converters

NOTE :

- 1) Unless otherwise specified, $T_a=25^\circ\text{C}$, 28V_{DC} V_{in}, 100% load.
- 2) Using tip and barrel measurement
- 3) To need times that Output voltage is renewed to 1% range of the stability value.
- 4) Only under the control of being machining for insulation resistance, each circuit should be assured to suffice need.

TYPICAL PERFORMANCE CURVES:

E.g. PX3028512T-15 :

1 : Output Ripple Voltage

2 : Start - Up

3 : Step load Response

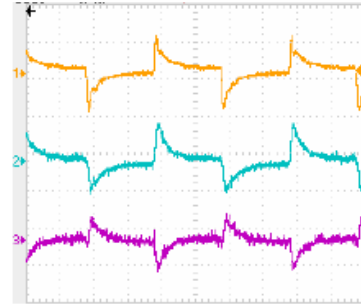
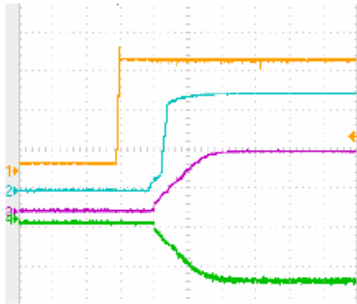
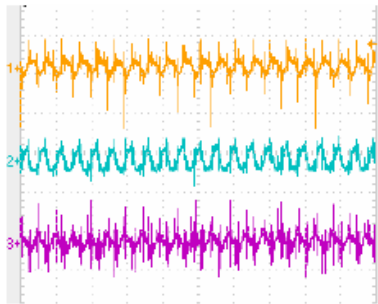

APPLICATION NOTE:

DC-DC converter typical connection shown as below:

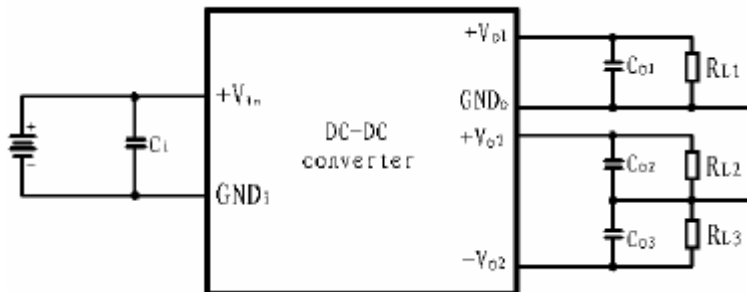

INHIBIT FUNCTION

The INH pin is used to achieve the function of external shut down. No connection to Pin 1 is necessary for normal operation of the converter. Shut down may be implemented by simply pulling the Pin 1 below 0.3V referenced to input common. The INH pin should be empty when not in use.

SHORT CIRCUIT PROTECTION

The PX302851*T-15 series of DC-DC converters offers the feature of short circuit protection. When it is working under load fault condition, the converter will automatically activate the short circuit protection and restore when the fault is removed.



POWERSTAX ref: PX302851*T-15 Series DC-DC Converters

RIPPLE VOLTAGE

While the output ripple voltage can't meet your application, it can still be suppressed by adding a filter capacitor between outputs and GND_O.

SYNCHRONIZATION

The PX302851*T-15 series of DC-DC converters is to be synchronized to an external clock. The frequencies range from 900 kHz to 1MHz, the levels from 4.5 V to 5.5V, the synchronization pulse width should be between 15ns and 150ns. A connection to pin 7 is not necessary for not in use.

REVERSE POLARITY PROTECTION

To avoid the input reverse connection, it's advised to connect a diode in series with the input pin of the converter (Shown as below).

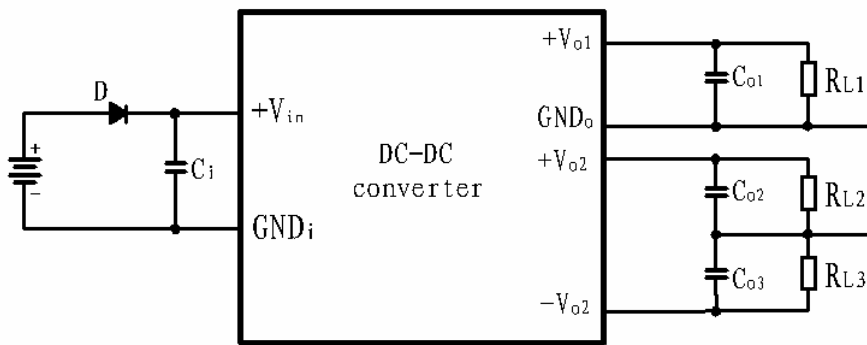

Notes :

- 1) Please properly connect pins of power module to PCB following instructions of part's specification.
- 2) To prevent pins of power module from being stressed to cause glass insulators cracked and power module leaked, please install power module with fixed flanges or screws prior to welding pins of power module.
- 3) The bottom of power module should be stressed to heat sink tightly. If necessary, thermal washers and shockproof gaskets are employed.
- 4) In any case, bending of pins should be avoided to keep glass insulators from cracking and prevent power module from leaking.



**POWERSTAX ref: PX302851*T-15 Series
DC-DC Converters**

ENVIRONMENTAL SCREENING:

M/E:					
Num	TEST ITEMS		METHODS	REQUEST	CONDITIONS
1	Internal Visual		MIL-STD-883 Method 2017	100%	---
2	Temp-Cycle		MIL-STD-883 Method 1010	100%	-55 °C to +125 °C, 10 times
3	Constant Acceleration		MIL-STD-883 Method 2001	100%	3000g, Y1, 1min
4	Burn-in		MIL-STD-883 Method 1015	100%	Tc : +105 °C 160h (M)
					Tc : +85 °C 96h (E)
5	Final Electrical Test	Natural Temperature	MIL-PRF-38534	100%	+25 °C
		High Temperature		100%	Tc : +105 °C(M)
		Low Temperature		100%	Tc : +85 °C(E)
6	Seal (Fine and Gross)		MIL-STD-883 Method 1014	100%	Fine Leak, Cond. A1
					Gross Leak, Cond. C1
7	External Visual		MIL-STD-883 Method 2009	100%	---
I:					
Num	TEST ITEMS		METHODS	REQUEST	CONDITIONS
1	Internal Visual		MIL-STD-883 Method 2017	100%	---
2	Burn-in		MIL-STD-883 Method 1015	100%	Tc +85°C 48H
3	Final Electrical Test		MIL-PRF-38534	100%	+25°C
4	External Visual		MIL-STD-883 Method 2009	100%	---



POWERSTAX ref: PX302851*T-15 Series DC-DC Converters

MECHANICAL SPECIFICATIONS:

Volume: 10.4cm³ Weight: ≤40g Packages: H and K for customers to choose
 Encapsulation: Hermetically Sealed Welded Seam Package Material: Cold Rolled Steel
 K form (e.g. PX3028515T-15M) :

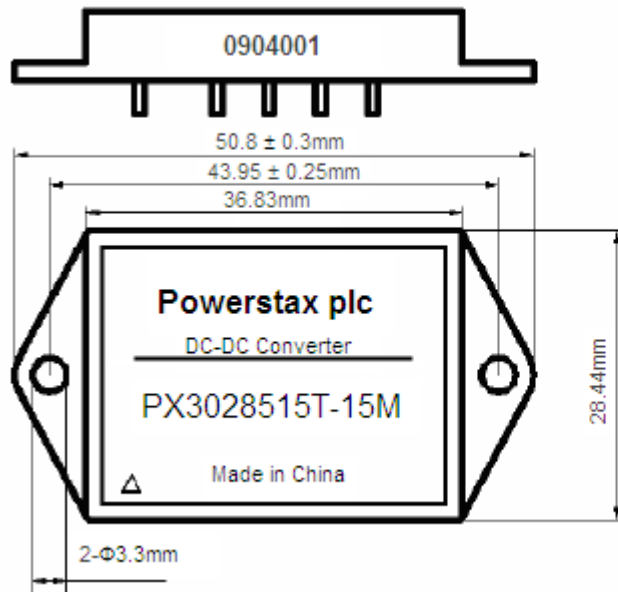

PIN	Pin Functions	
1	Inhibit	INH
2	Output 1+	+Vo1
3	Output Common	GND _o
4	Output 2+	+Vo2
5	Output 2	-Vo2
6	Case Ground	Case
7	Sync	Sync
8	Input Common	GND _i
9	Input +	+Vin

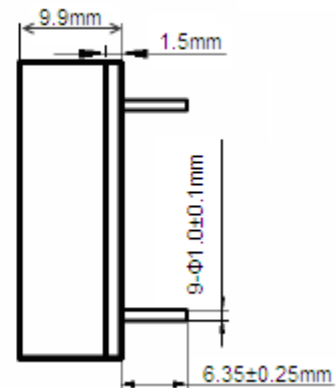
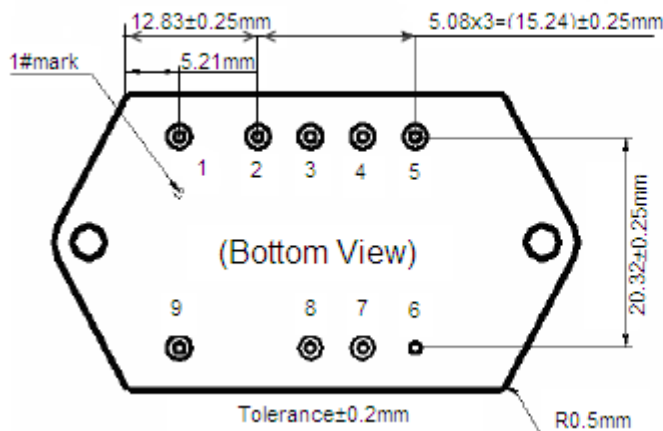



POWERSTAX ref: PX302851*T-15 Series DC-DC Converters

H form (e.g. PX3028515T-15HM):

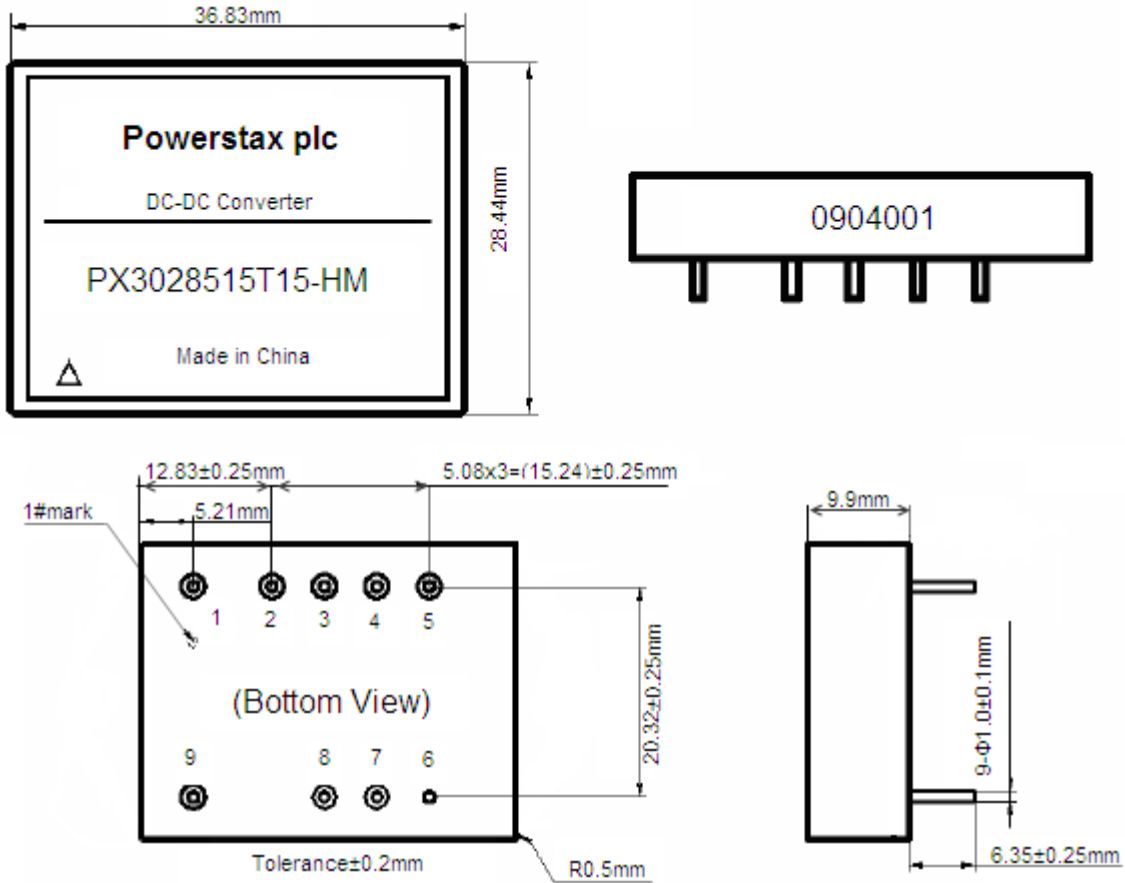

ORDERING INFORMATION:

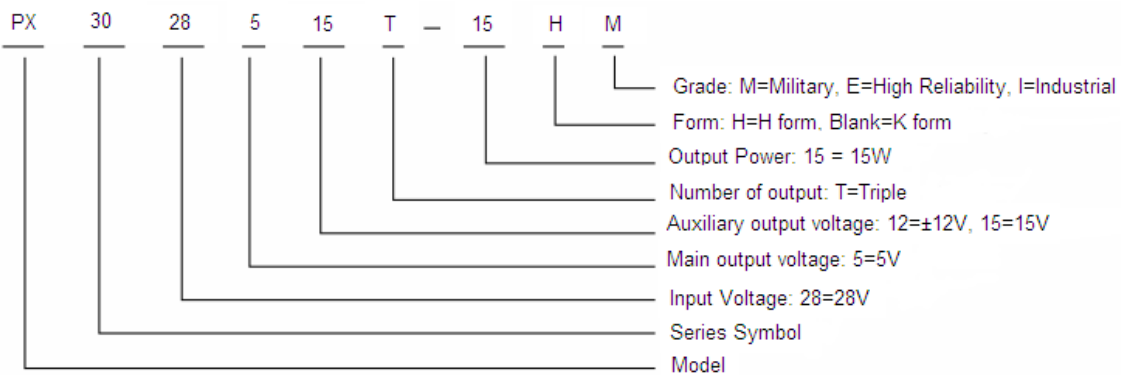

MARK SPECIFICATION:

Serials Number: 0904 001, which indicates this product has been manufactured in the 4th week of 2009, and the sequence number is 001.