



PX-285XXT-30 triple output High Reliability DC-DC Converters

- ❑ High reliability, small size
- ❑ High power density: 21w/in³
- ❑ Input Voltage range: 16VDC~40VDC
- ❑ Output Power: 30W
- ❑ Inhibit and synchronization functions
- ❑ Input to output isolation
- ❑ In Photoelectric Isolation
- ❑ Output over current /short circuit protection
- ❑ DIP full metal sealed



DESCRIPTION:

The PX285XXT-30 triple output series module, which adopts Thick-Film microcircuit technology, is a kind of perfect converter with high reliability necessary for some applications such as aviation, aerospace and military. The main output voltage is 5V, and the auxiliary output voltages is $\pm 12V$ or $\pm 15V$. The output power is 30W. The switching frequency is fixed at 265 KHz to minimize noise. The input filter circuit is designed to reduce the electro-magnetic interference. The typical input voltage is 28V, and the ranges from 16V to 40V. The PX285XXT-30 series also provides some control functions such as synchronization, shut down, and over-current and short circuit protection.

BLOCK DIAGRAM:

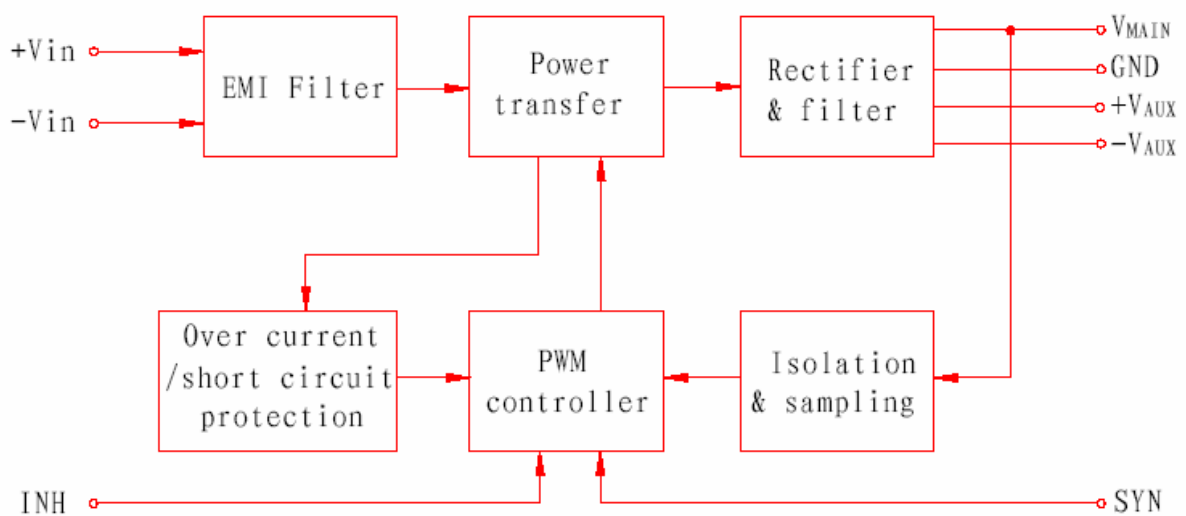

ABSOLUTE MAXIMUM RATINGS:

Input Voltage: +16Vdc to +40Vdc

Output Power: 30W Storage Temperature range(Tc):-65°C~+150°C(M)/ -55°C~+125(E)°C

Pin-Solder Temp (10s): 300°C Case Operating Temp (Tc): -40°C to +75°C(I)/ -55°C to +100°C (M)

ELECTRICAL CHARACTERISTICS:

25°C Ta, 28VDC Vin, 100% load, unless otherwise specified.

PARAMETER	CONDITIONS	PX-28512T-30			PX28515T-30			UNITS
		MIN	TYP	MAX	MIN	TYP	MAX	
OUTPUT VOLTAGE	VIN=16VDC~40VDC VMAIN	4.95	5.00	5.05	4.95	5.00	5.05	V
	VIN=16VDC~40VDC +VAUX	11.82	12.00	12.18	14.77	15.00	15.23	
	VIN=16VDC~40VDC -VAUX	11.82	12.00	12.18	14.77	15.00	15.23	
OUTPUT CURRENT	VIN=28VDC VMAIN	0.5	-	4.0	0.5	-	4.0	A
	VIN=28VDC +VAUX	-	-	0.416	-	-	0.333	
	VIN=28VDC -VAUX	-	-	0.416	-	-	0.333	
OUTPUT POWER	VIN=28VDC VMAIN	-	-	20	-	-	20	W
	VIN=28VDC +VAUX	-	-	5	-	-	5	
	VIN=28VDC -VAUX	-	-	5	-	-	5	
	TOTAL POWER	-	-	30	-	-	30	
OUTPUT RIPPLE VOLTAGE ¹	20MHZ VMAIN	-	50	115	-	50	115	mVp-p
	±VAUX	-	20	80	-	20	80	
LINE REGULATION	VIN=16VDC~40VDC VMAIN	-	10	20	-	10	20	mV
	±VAUX	-	25	60	-	30	75	
LOAD REGULATION	VMAIN	-	10	20	-	10	50	mV
	±VAUX	-	30	75	-	30	75	
INPUT VOLTAGE	CONTINUOUS	16	28	40	16	28	40	V
	50V/50ms	-	-	50	-	-	50	
INPUT CURRENT	NO LOAD	-	70	100	-	70	100	mA
	FULL LOAD	-	1.37	1.45	-	1.37	1.45	A
	INHIBITED	-	3.0	8.0	-	3.0	8.0	mA
INPUT RIPPLE CURRENT	20MHZ	-	20	40	-	20	40	mA p-p
EFFICIENCY		72	75	-	73	75	-	%
LOAD FAULT SHORT CIRCUIT TO FULL LOAD	SHORT CIRCUIT POWER DISSIPATION	-	-	14	-	-	14	W
	RECOVERY	-	1.4	2.0	-	1.4	2.0	ms
STEP LOAD RESPONSE TRANSIENT	50%~100%~50% VMAIN	-	150	250	-	150	250	mV
	25%~50%~25% ±VAUX	-	500	750	-	500	750	mV
STEP LOAD RESPONSE TRANSIENT RECOVERY ²	50%~100%~50% VMAIN	-	0.05	0.10	-	0.05	0.10	ms
	25%~50%~25% ±VAUX	-	3	5	-	2	5	
STEP LINE RESPONSE	OVERSHOOT VMAIN	-	150	250	-	150	250	mV
	±VAUX	-	100	250	-	100	250	
START-UP	DELAY	-	1.4	2.0	-	1.4	2.0	ms
	OVERSHOOT VMAIN	-	0	500	-	0	500	mVpk
	±VAUX	-	0	1500	-	0	1500	
Insulation Resistance	Vin,Vo,Case (500Vdc)	100	-	-	100	-	-	MΩ

NOTE:

1. Using tip and barrel measurement.

2. Recovery time is measured from application of the transient to point at which Vout is within 1% of final

Application Notes:

Over current/Short Circuit Protection

The PX-285XXT-30 series of DC-DC converters has the function of over current/short circuit protection. When it is working under load fault condition, the converter will automatically activate the over current/short circuit protection and restore when the fault is removed. It is suggested that the duration of the current/short must be less than 10s, and the case temperature lower than 105°C. Otherwise, the module will be disabled.

Inhibit Function:

The INH pin is used to achieve the function of external shut down. No connection to Pin 8 is necessary for normal operation of the converter. Shut down may be implemented by simply pulling the Pin 2 below 0.3V referenced to input common..

Ripple Voltage Suppress:

While the output V-ripple can't satisfy your application, it can still be suppressed by adding a filter capacitor between Vo+ and Vo- outputs. The optimal value for this capacitor is recommended at around 50V/ 10μF with film or ceramic capacitor as preferable options.

Synchronization

The PX-285XXT-30 series of DC-DC converters allow the designer to match the switching frequency of the converter to the frequency of the system clock or synchronize several modules by synchronization pin. Frequency ranges from 260 to 350 KHz, the level from -0.3 to 10V, and duty cycle from 40% to 60%. Under master and slave configuration, the master module will offer ±3mA current and the slave ones ±0.5mA in maximum.

Reverse Polarity Protection:

To avoid the input reverse connection, it's advised to connect a diode in series with the input pin of the converter. (Shown as below)

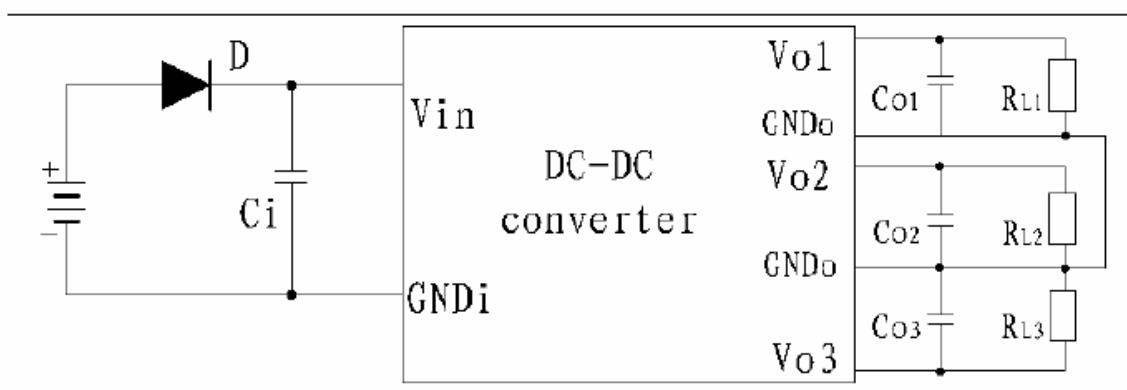

**PX-285XXT-30 triple output
High Reliability DC-DC Converters**



ORDERING INFORMATION:

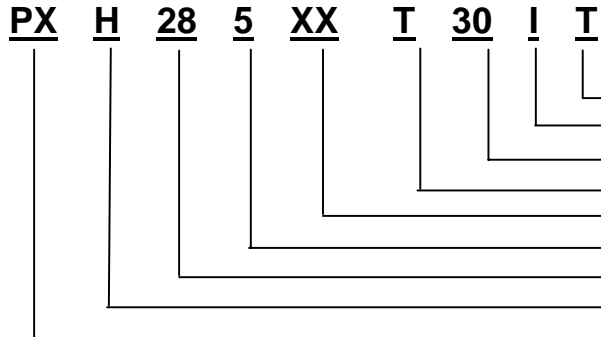

Case Style – Blank = standard case, T = With tabs
 Grade – M = MIL, H + High Rel, I = Industrial
 Watts = e.g. 15, 30 etc.
 Number of outputs S = Single, D = Dual, T = Triple
 Aux output voltage: 15 = ±15V
 Main Output Voltage 5 = 5V
 Nom Input Voltage – 12, 24 etc
 Blank=No seal, H = Hermetically, S = Stannic Seam
 Series Name

Military (M) and high reliability (H) products adopt Parallel seam welding process. There are two kinds of form (Standard and Tabbed) for customers to choose, please mark it when purchasing.

Mark specification:

Serials Number: DC 0621 001, which indicates this product has been manufactured in the 21st week of 2006, and the sequence number is 001.

Environmental Screening

Environmental Screening(M/E)			
Test item	Method	Request	Condition
PRE-CAP Inspection	MIL-STD-883 Method 2017	100%	---
Temp-Cycle	MIL-STD-883 Method 1010	100%	-65°C to+ 150°C(M) , 10 times -55°C to +125°C(E) , 10 times
Constant Acceleration	MIL-STD-883 Method 2001	100%	3000 g, Y1, 1min
Burn-in	MIL-STD-883 Method 1015	100%	Tc +105°C(M)/+85°C(E), 160h
Final Electrical Test	MIL-PRF-38534	100%	-55°C, +25°C, +105°C(M) -40°C, +25°C, +85°C(E)
Hermeticity Testing	MIL-STD-883 Method 1014	100%	Fine Leak, Cond. A1 Gross Leak, Cond. C1
Final Visual Inspection	MIL-STD-883 Method 2009	100%	---



MECHANICAL SPECIFICATIONS:

Volume: 20.2cm³

Weight: ≤72g

Encapsulation: Seam Seal Shell

Material: Cold Rolled Steel

Package style: Two kinds of form for customers to choose (Standatd & Tabbed)

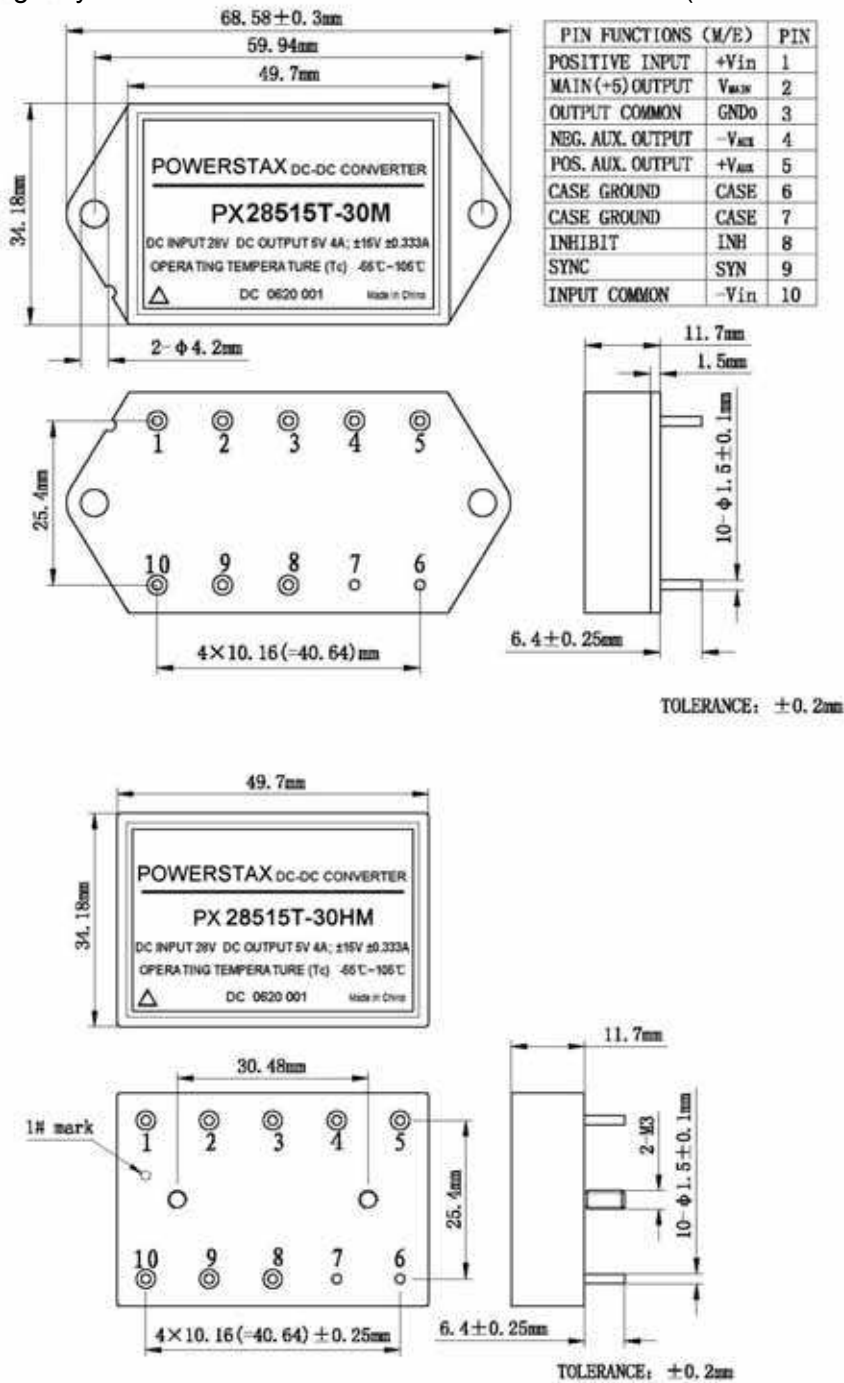

Exceeding absolute maximum ratings may cause permanent damage and may reduce reliability. Information and specifications contained in this data sheet are believed to be correct at the time of publication. However, Powerstax accept no responsibility for consequences arising from printing errors or inaccuracies. Specifications are subject to change without notice.