



A0800 AC-DC POWER MODULE 800W

Universal AC Input: 85V to 264V, Single DC Output: 48 - 56.2VDC

FEATURES

- ❑ High power density, 8.2W / in³
- ❑ Net Weight: 2.2 KG typ.
- ❑ Low profile : 40.8mm
(fit 1U shelf – R2400 series)
- ❑ Universal AC input
- ❑ Efficiency: 84% ~ 88 % typical
- ❑ Power factor correction
(meet IEC1000-3-2 requirements)
- ❑ Overvoltage & overcurrent protection
- ❑ Over-temperature warning & protection
- ❑ Redundant parallel operation up to 12 units
- ❑ Remote On/Off and remote sense
- ❑ Active load sharing
- ❑ Hot insertion / removal (Hot Swap)
- ❑ Power fail warning and fault alarm
- ❑ 400Hz input available
- ❑ I²C for voltage, current, temperature report & Power Supply ID.
- ❑ Front panel LED indicator
- ❑ Low Start-Up Temp: -30°C

The Powerstax A0800 series of front-ends power modules is specifically designed to operate as an integral part of a complete distributed power system, with or without battery backup.

A full complement of protection, alarm and control features has been incorporated into the power unit to provide the versatility of applications.

The flexible feature set makes this front-end power module an excellent choice for applications requiring modular AC-to-DC power systems such as distributed power and DC UPS.

Applications

- ✓ Advanced workstations
- ✓ Telecom / Datacom equipment
- ✓ Midrange computers
- ✓ Mainframes
- ✓ File servers
- ✓ LAN/WAN applications
- ✓ Mass storage





Input Specification

Parameter	Min	Typ	Max	Unit	Condition
Input voltage	85	-	264	Vac	750W max for under 90V AC input
Input Frequency	47	-	63	Hz	400Hz available with safety approvals. Consult APC for details
Inrush Current (peak)	-	-	50	A	
Power Factor	0.95	0.99*	-	-	≥ 50% of full load
Input Leakage Current	-	-	1.7	mA	264Vac, 50Hz
Line Harmonics	-	-	-	-	Meet IEC1000-3-2
Lighting Surge & Transients (damage free operation)	-	-	-	-	1) IEC1000-4-5 Level 3 2) IEC1000-4-4 Level 3
Hold Up Time	20	-	-	mS	Please see curve below
EMC (conducted)	-	-	-	-	CISPR22 Class B, EN55022 Class B, with 3dB margin

Hold Up Time

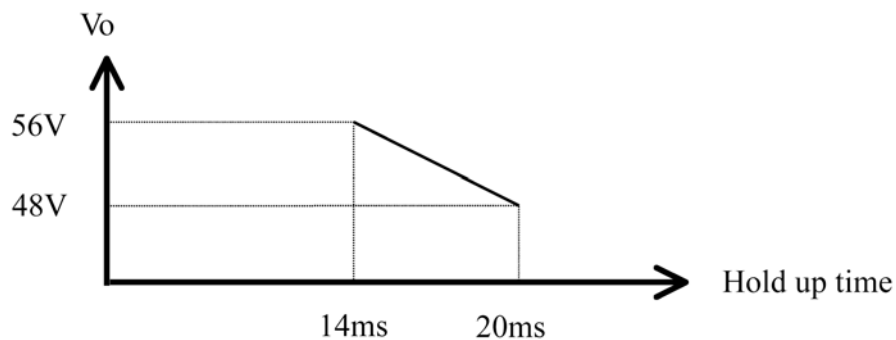

Efficiency and Power Factor vs. Input Voltage at full load

Input voltage	Efficiency (Typical)	Power Factor (Typical)
90Vac	83%	0.99
100Vac	84%	0.99
120Vac	85%	0.99
160Vac	85%	0.98
190Vac	86%	0.98
220Vac	86%	0.98
240Vac	87%	0.98
264Vac	88%	0.98

Notes:

When using this table to calculate line cord requirements, allow, at a minimum, an extra 3% for variations between units. Actual measured results will depend upon the harmonic content of the input voltage waveform.



Output Specification

Parameter	Min	Typ	Max	Unit	Note
Vo set point:					
APC-A0800-085-480	-	48.0	-	Vdc	
APC-A0800-085-545	-	54.5	-		
APC-A0800-085-562	-	56.2	-		
Regulation (line, load, temperature & set point)	-2.0	-	2.0	%	Measured at remote sense
Remote-sense Drop	-	-	0.5	Vdc	
Io (rated)					
APC-A0800-085-480	0	-	16.6	Adc	800W maximum
APC-A0800-085-545	0	-	14.7		800W maximum
APC-A0800-085-562	0	-	14.2		800W maximum
Capacitive Load			10,000	uF	
Ripple & Noise (50MHz bandwidth)			300	mVp-p	Under any load conditions
Transmission Noise (C message)	-	-	45	dBmc	
Output Rise Time	20	40	100	mS	Rise from 10% to 90% of final output level (resistive load)
Overvoltage Protection	62.0	-	64.0	Vdc	Reset by cycling ac input, pressing RESET, or reinsertion
Output Current Limit (Steady state)	-	-	23	Adc	See Fig. 1
Transient Response					25% step load transient with slew rate 0.1A/us within range from 25% to 75% of full load
Voltage Range	-1.0	-	1.0	%	
Active Current Sharing Differential	-	-	±1.7	A	Single-wire current share at full load
Efficiency	83	85	-	%	At full load, 120 Vac with Oring diode
	87	88	-	%	At full load, 264 Vac with Oring diode
Reserve Output Current Protection	-	-	-	-	ORing diode
Start-Up delay	-	1.3	2	s	Measured from application of valid ac voltage
Turn On delay			200	mS	Measured from DC on/off



Characteristic Curves

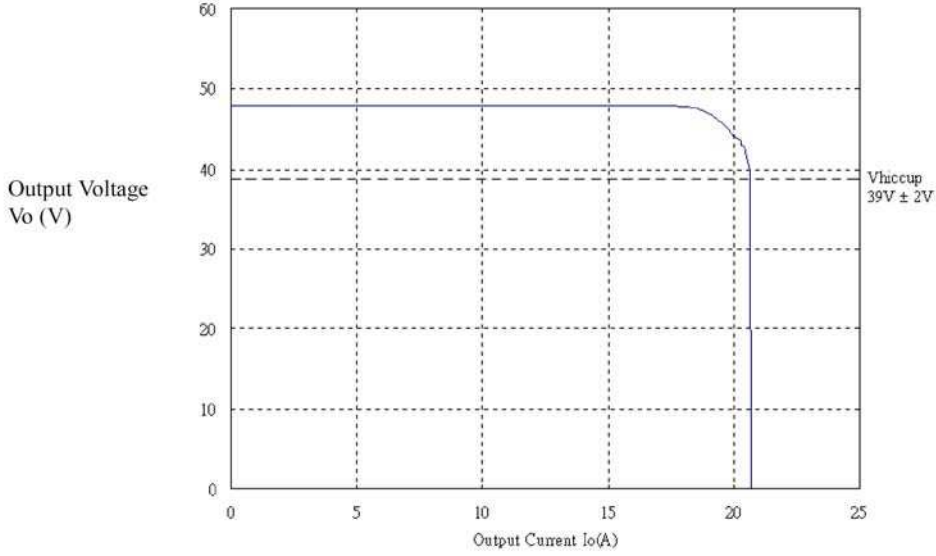

Figure 1. Output voltage vs. output Current

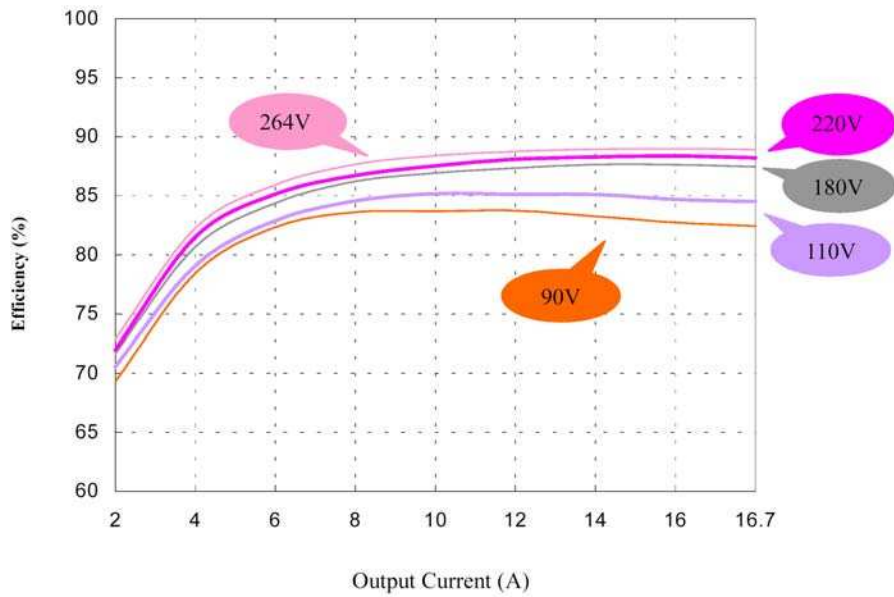
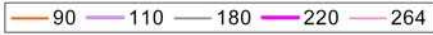

Figure 2. Efficiency vs. output current at different input voltage.



Characteristic Curves

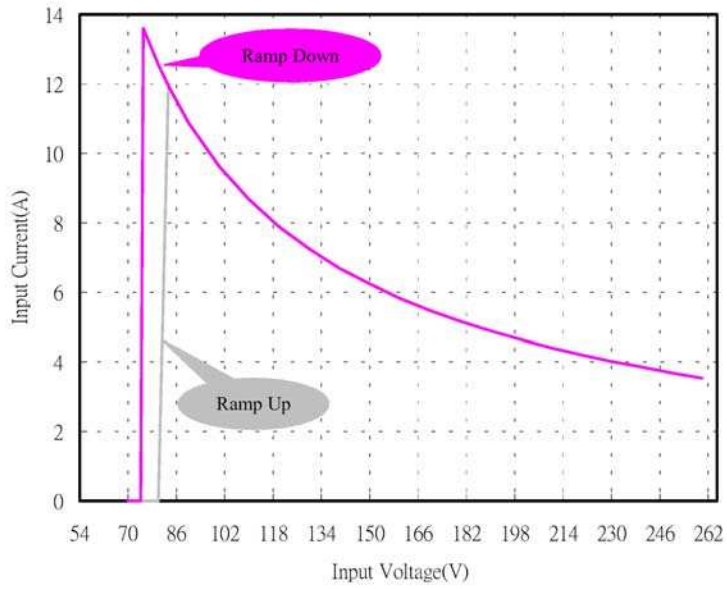

Figure3 Typical Input Current vs. Input Voltage at full load.

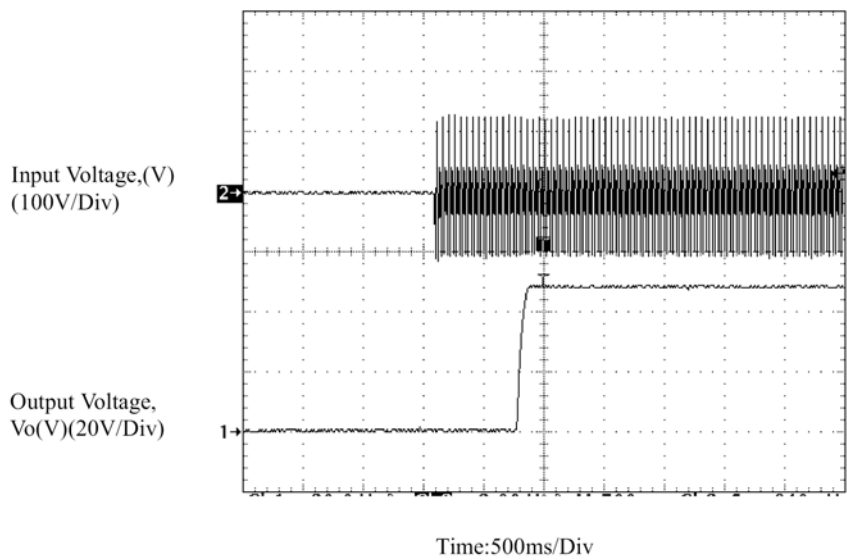

Figure 4 Typical Start-up transient at room temperature, When 90Vac Input voltage is applied.



Characteristic Curves

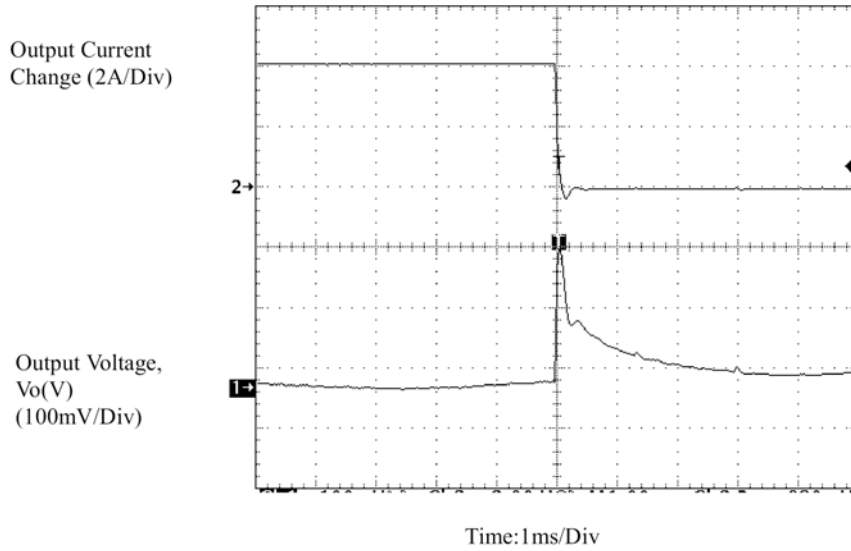

Figure 5. Typical transient: load changes from 12.45A to 8.3A @ 25°C and 90Vac input.

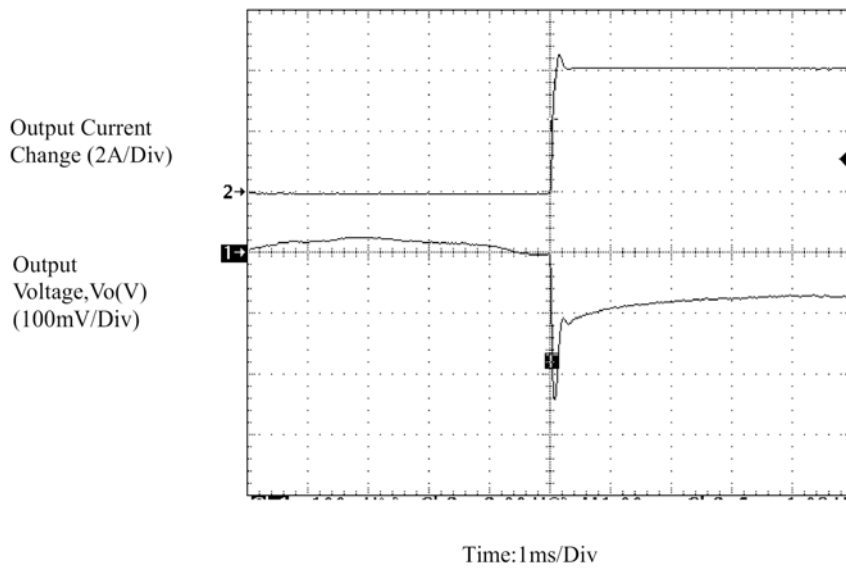

Figure 6. Typical transient: load changes from 8.3A to 12.45A @ 25°C and 90Vac input.



Characteristic Curves

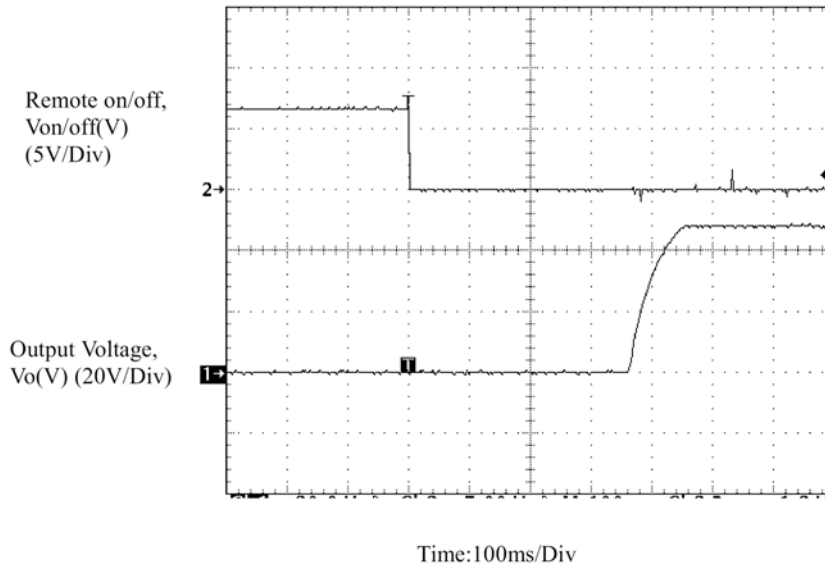

Figure 7. Typical turn-on timing at 25°C , 90Vac input when signal is applied to remote On/Off pin.

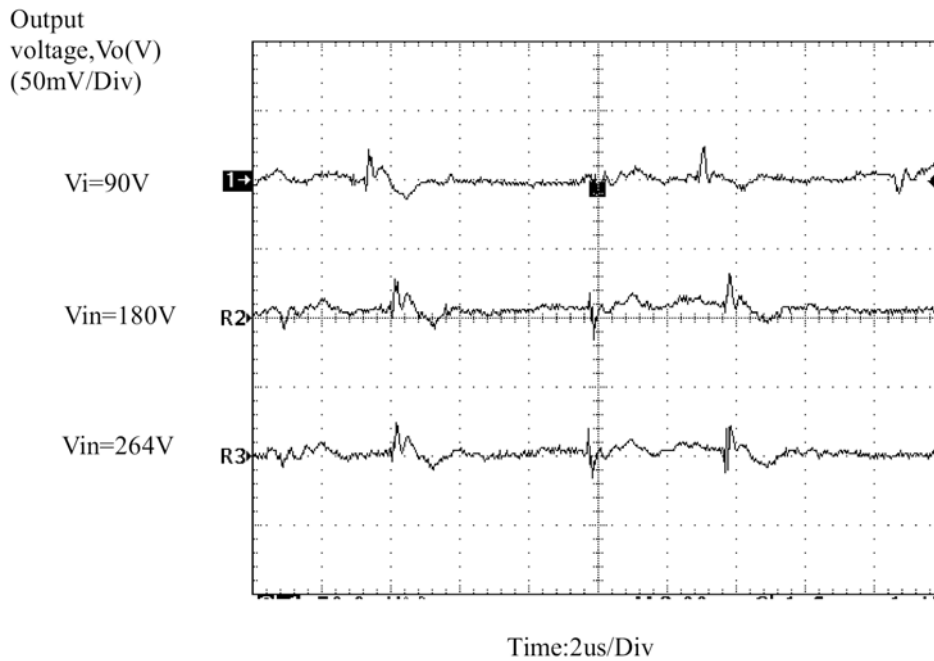

Figure 8. Typical output ripple voltage at 25°C ; 15.6A output current.



Environmental Characteristics

Parameter	Min	Typ	Max	Unit	Note
Storage Temperature	-40	-	85	°C	
Operating Temperature (note 1)	0	-	60	°C	Derating 5% / °C, 50°C to 60°C. (see curve below)
Acoustics	-	47	52	dBa	ISO 7779 SPL
Humidity (non-condensing)	5	-	95	%	
Altitude	-200	-	13,000	Feet	Derated at 2°C/1000 ft. above 8000 ft.
ESD	-	-	-	-	meet IEC1000-4-2 Level 3 stand-alone
Electromagnetic Immunity (error free)	-	-	-	-	meet IEC1000-4-2 Level 2 stand-alone
Isolation	3,000VAC				Primary to Secondary
	1,500VAC				Primary to chassis GND
	500VAC				Secondary to chassis GND
MTBF	4×10^5	-	-	hours	@110V Input 80% load, T _A = 30°C
Vibration					Meet IEC68-2-6
Shock					Meet IEC68-2-36
Weight	-	2.2	-	Kg	

Thermal Derating Curve

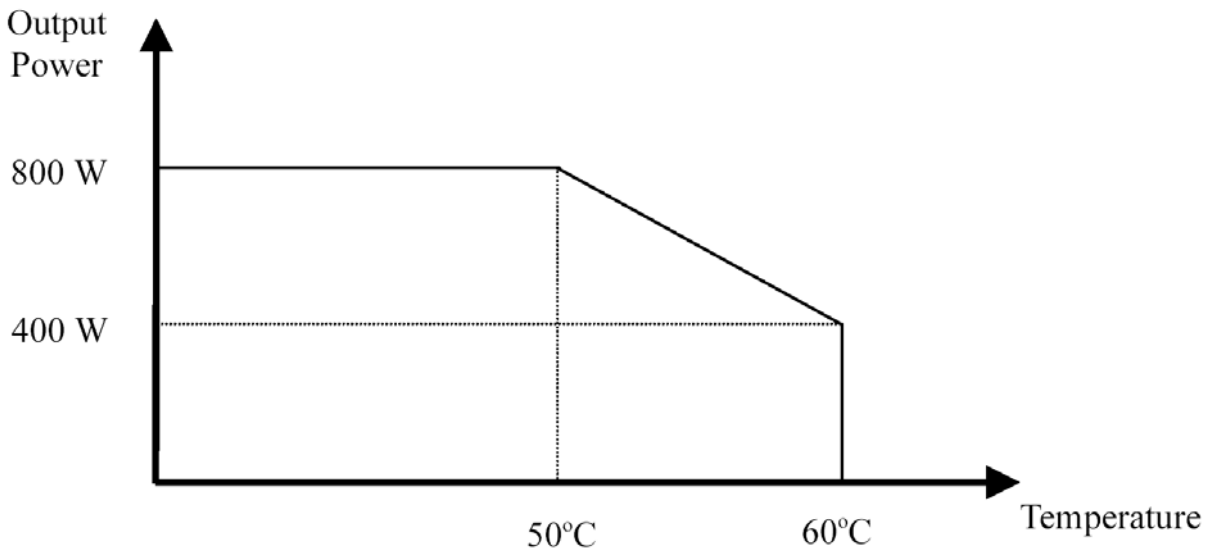



Power Module Interfaces

Input Voltage

The product can be used with any standard global line voltage; consult Powerstax for any particular regional application concerns.

Input / Output Connector

The input / output connector is PCIB24W9M400A1 / Postronic, with 9 power pins and 15 signal pins. 3 out of the 9 power pins are for the AC input.

Connector Pin Assignment - view into rear of power unit

Please refer to “ Definition of Terms “ for detailed description for each pin

1	3	5	7	10	13	16	19	23
V+	V+	V+	ON/OFF	RS-	CS	OTP	DC FAIL	LINE
			8	11	14	17	20	
			N.C.	SDA	Signal RTN	A2	A1	
2	4	6	9	12	15	18	21	22
V-	V-	V-	RS+	SCL	A3	A0	INT. BUS	FG
								24
								Neutral



Timing Chart

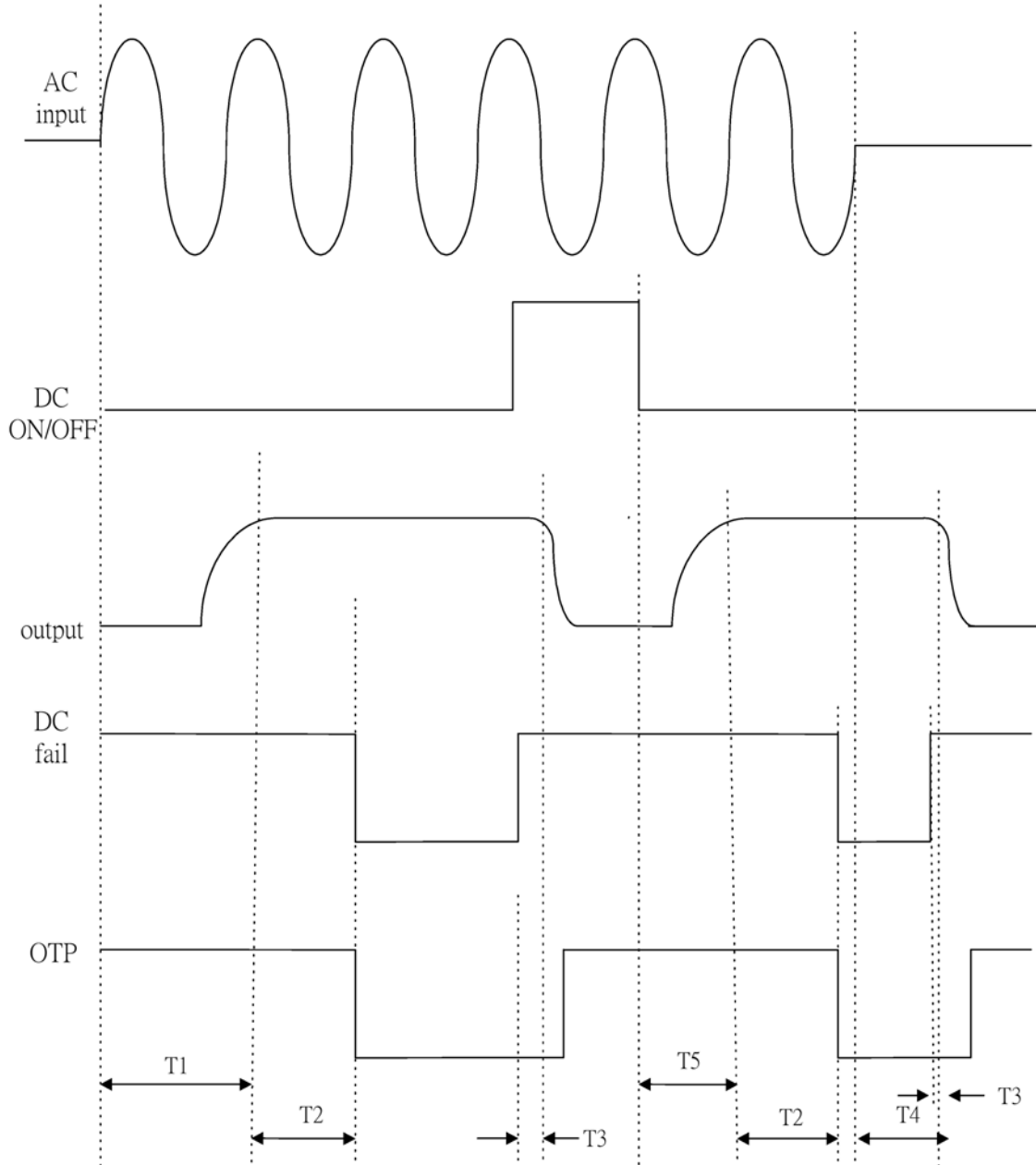

	T1	T2	T3	T4	T5
	Start up delay			Hold up time	Turn on delay
Min.		200	1	14~20*	
Typ.	1300	270			
Max.	2000	600	4		200
Units	mS	mS	mS	mS	mS

* Depend on output voltage



SMBus Function

Function	Command Code	Protocol*1			Unit
Temperature	0x08	Read	Word	No PEC	° K
Voltage	0x09	Read	Word	No PEC	mV
Current	0x0A	Read	Word	No PEC	mA
Manufacture Date*2	0x1B	Read	Word	No PEC	
Serial number	0x22	Read	Word	No PEC	
Manufacturer Name	0x20	Read	Block*3	No PEC	
Device Name	0x21	Read	Block*3	No PEC	
Manufacture Data (Version)	0x23	Read	Block*3	No PEC	

1. Reference: System management bus specification v1.1

2.The date is packed in the following fashion:

(Year - 1980) * 512 + Month * 32 + Day = data byte high: data byte low

Field	Data byte	Allow value
Day	Bit 0~4	1 - 31 (corresponds to date)
Month	Bit 5~8	1 - 12 (corresponds to month number)
Year	Bit 9~15	0 - 127 (corresponds to year biased by 1980)

Example: 2001/11/29 = 10101101111101 (bin) = 2B7D (hex)
 Where 2B(hex) is data byte high, 7D(hex) is data byte low.

3.Read block data byte 1~N is in ASCII code, where N is the value of byte count.

Address Definition

RACK	Shelf	P.S. No.	Address	A3	A2	A1	A0
	1	1	0x00	0	0	0	0
		2	0x02	0	0	0	1
		3	0x04	0	0	1	0
	2	4	0x20	0	1	0	0
		5	0x22	0	1	0	1
		6	0x24	0	1	1	0
	3	7	0x40	1	0	0	0
		8	0x42	1	0	0	1
		9	0x44	1	0	1	0
	4	10	0x10	1	1	0	0
		11	0x12	1	1	0	1
		12	0x14	1	1	1	0

A0800 AC-DC POWER MODULE 800W
 Universal AC Input: 85V-264V, Single DC Output: 48-56.2V

Product Specification



Mechanical Outline

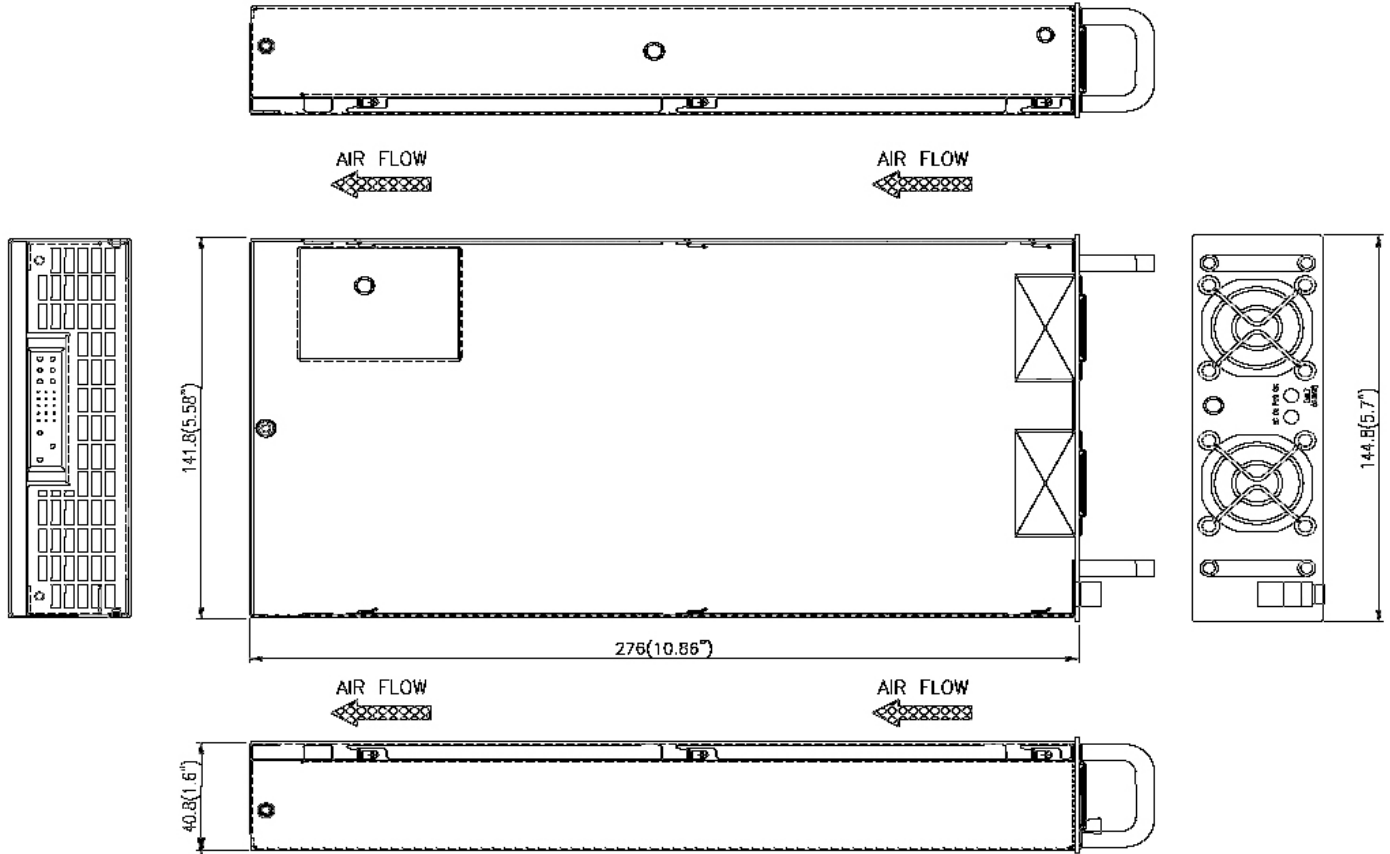

Model Reference Guide

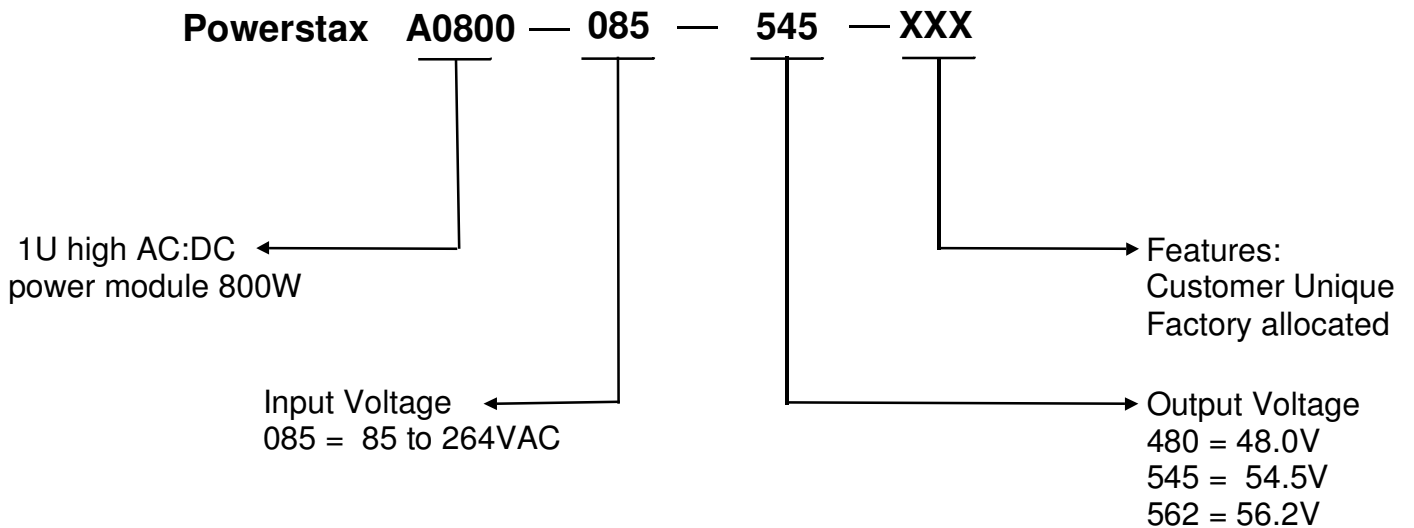



Definition of Terms

AC Line Discrimination

The unit senses the input line range at power up and shuts the unit down if the input drops below the line range for a specified period of time.

Current Monitor

The output current could be reported through the I2C bus.

Front Panel LEDs

LED 1 -- AC OK (green): Input voltage OK

LED 2 -- Output OK (green): The unit is powered up and operating normally

or

Output fail (amber): The unit has detected an internal fault.

Input Overcurrent Protection

An internal fuse is provided for input protection in compliance with safety agency requirements.

Current Share Bus (CS)

A single-wire interface between each of the power units forces them to share the load current equally.

Overcurrent Protection

In the event of an overload condition, the power supply limits the output current.

Overvoltage Protection

The power unit turns itself off before the output voltage reaches the OVP threshold.

I²C Serial Bus Interface support

The power unit provides I²C serial bus interface to receive/transmit data

SCL: Clock signal input for I²C functionality.

SDA: Data signal I/O for I²C functionality.

A0~A3: Address pin for I²C address Bit 0~3.

ORing Diode

A diode at the output of the power unit protects the DC bus during a power supply failure or hot plugging of the power unit.

Overtemperature Protection

In the event of an overtemperature condition, the power unit protects itself by shutting off, restarts automatically after cooling down.

Remote Sense (RS+, RS-)

These signals permit the power units to compensate for a voltage drop across the output distribution.

On/Off

This is an input signal referenced to the negative output. Shorting this signal to the negative output will turn on the power unit.

Status Signals

The following are the optically isolated open-collector signals:

DC FAIL: This signal indicates the output fail. It becomes low with a turn on delay of 100 to 500mS after the output voltage reaches in the regulation window. It will go to a high level at least 1mS before output voltage runs out of regulation window.

OTP: This signal indicates fan fail or over temperature. It becomes low with a turn on delay of 100 to 500mS after the output voltage reaches in the regulation window. It will go to a high level 200mS before the unit shuts down if a fan fail or over temperature is sensed.

The logic low level is lower than 0.6V with the sink current of the photo-transistor less than 1mA.

INT. bus

Intermediate DC bus. It is a DC output from the power module for shelf internal usage. There is a reserved slot for a DC/DC converter on the back plane of the power shelf. The DC/DC may transfer DC bus voltage to a standby DC output that may be customized upon request.