

SAR-10197 Aerospace Battery

Lithium-Ion – Lithium Cobalt Oxide
Rechargeable



Lithium-ion provides higher energy levels and longer cycle life, at a lower weight and smaller volume, with less maintenance than lead acid, Ni-Cd, or Ni-MH batteries.

Features & Benefits

- ✦ Autonomous cell bypass capability
- ✦ Primary and redundant heaters
- ✦ Back-up temperature and voltage telemetry
- ✦ Built-in cell safety protection
- ✦ Current sense capability
- ✦ Operational for 15-year mission life (GEO)
- ✦ Space flight heritage
- ✦ High reliability > 0.99
- ✦ Built-in lifting points with detachable lifting fixture
- ✦ Designed for radiation total-dose exposure of 3.11E6 rads
- ✦ Connector savers for spacecraft integration and test bracket
- ✦ Custom connectors are keyed and clocked per customer specification; MIL-DTL-38999 and/or NASA-S-311-P-768 connectors available upon request
- ✦ Subjected to vibratory and thermal-vacuum testing

Specifications

Part Number	SAR-10197
Weight Not to Exceed	140 lb/63.5 kg
Nominal Voltage	33.3V
Operating Voltage	27.0V to 35.8V
Beginning of Life Capacity/Energy	200Ah/6660WH @ 20°C
Maximum Dimensions	10.6"W x 29.5"L x 10.4"H
Specific Energy	104.9 Whr/Kg
Operating Temperature	-5°C to 35°C
Survival Temperature (non-op)	-15°C to 40°C
Charge Current (Max)	100A
Maximum Continuous Discharge	154A
Maximum Discharge Pulse	400A for 1 sec
Random Vibe Levels	14 GRMS
Sine Vibe Levels	15G
Shock Level	1135G

Applications

- ✦ Military communications and surveillance
- ✦ Commercial communication and broadcasting
- ✦ NASA research
- ✦ Environmental monitoring
- ✦ Global navigation and tracking

SAR-10197

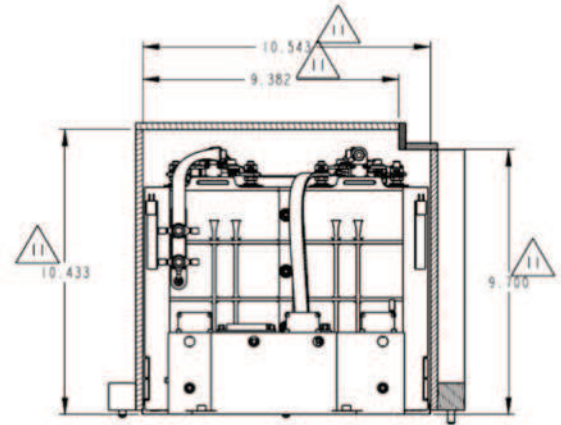
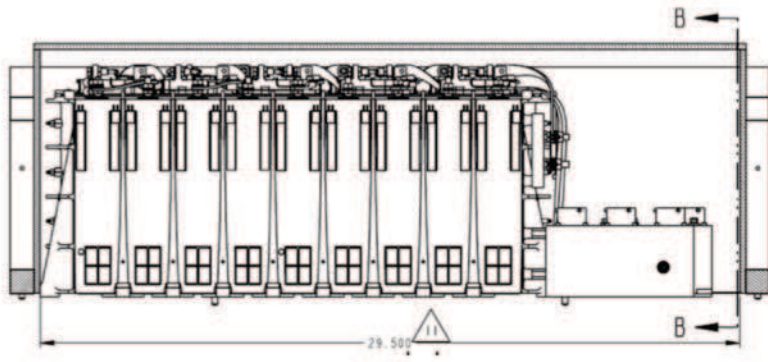

SAR-10197 CHARGE/DISCHARGE VOLTAGE PROFILES

