

CP16 CompactPCI® SINGLE BOARD COMPUTER

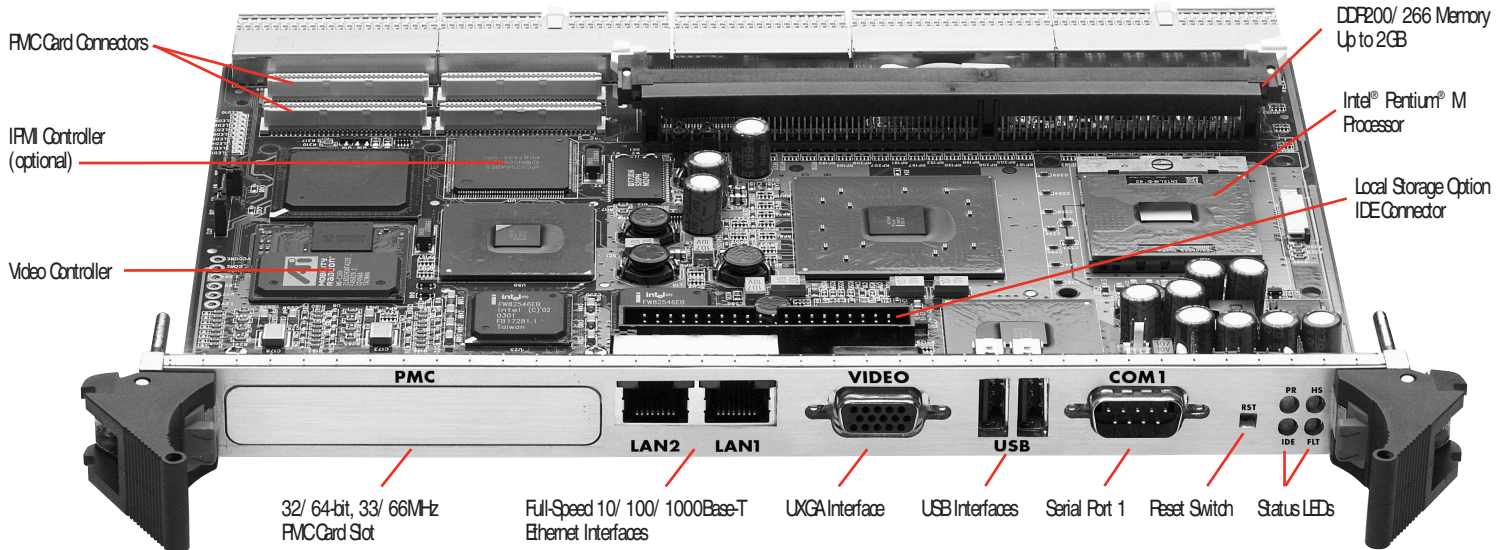

The flexible design features of Trenton's CP16 enable the SBC to excel in a wide variety of applications. Optional plug-in local storage, the ability to switch off the CompactPCI® bus, PICMG® Packet Switching Backplane, Hot Swap and IPMI support enable the CP16 for use in CompactPCI system board or server blade computing applications.

PROCESSOR:

Intel® Pentium® M processor at speeds of 1.3GHz to 1.8GHz* Processor Package: Micro-FCPGA

*Higher speeds as available

The Intel® Pentium® M processor combines micro-architecture enhancements with innovative power management techniques to produce a processor ideal for CompactPCI applications. These enhancements and innovations include:

- A2MB Level 2 (L2) cache memory is available on processor speeds 1.8GHz and above. Processors below 1.8GHz have an L2 cache of 1MB.
- Enhanced Intel SpeedStep® Technology (EST)
- Processor speeds of 1.8GHz and above are produced using Intel's 90nm process technology. Processors below 1.8GHz use the .13 micron process.
- New micro-op engine (Micro-op fusion)
- Demand Based Switching (DBS)
- Advanced branch prediction unit

CHIPSET:

The CP16 uses Intel's E7501 chipset which provides support for DDP200/ 266 memory with ECC and a high-speed Hub Link 2.0 interface. Intel® Pentium® M processors support a 400MHz FSB.

PMC OPTION CARD SLOT:

FMC32/ 64-bit, 33/ 66MHz option cards are supported by the CP16 via an access slot in the SBC's front panel.

PACKET SWITCHING BACKPLANE SUPPORT:

Channel B of each Ethernet controller provides a redundant 10/ 100/ 1000Base-T Ethernet interface via connector J3 to the CompactPCI backplane. This allows Ethernet communication and control between the CP16 and other boards in the CompactPCI chassis. The interface implementation is fully compatible with the RGMII 2.16, R1.0 specification.

CompactPCI® BUS:

The CP16 provides direct support for up to seven expansion CompactPCI slots at 32-bit/ 33MHz and up to four expansion slots at 64-bit/ 66MHz. Each slot provides support for PCI Bus mastering. The CompactPCI bus can be turned off via the CP16's CompactPCI bus switches for server blade applications.

LOCAL STORAGE OPTION:

A Compact Media Daughter Card (CMD) plugs into connector P1A on the CP16 and provides support for either a CompactFlash™ or Microdrive storage device. In server blade applications this option is useful for storing the operating system and application.

HOT SWAP & IPMI SUPPORT:

The CP16 offers standard support for the Hot Swap (RGMII 2.1, P2.0) and Hot Swap Infrastructure (RGMII 2.12, P2.0) specifications with optional support available for the Intelligent Platform Management Interface (IPMI, RGMII 2.9, R1.0). Consult Trenton for ordering details.

BUS SPEEDS:

CompactPCI Bus	- 32-bit/ 33MHz, 32-bit/ 66MHz, 64-bit/ 33MHz, 64-bit/ 66MHz
PCI-X Local Bus	- 64-bit/ 100MHz
PCI Local Bus	- 32-bit/ 33MHz & 64-bit/ 66MHz
Hub Link 2.0*	- 1GB/s
System or FSB	- 400MHz

*Hub Link D is routed to J4 for high-speed interface usage on the optional R1M25.

BIOS (FLASH):

The CP16's BIOS is AMIBIOS8 with optional IPMI extensions. The flash BIOS resides in the 82802 Firmware Hub (FWH). Some of the key features of the BIOS are:

- Boot from network, USB mass storage devices, IDE, ATAPI or SCSI
- Serial port console redirection to support headless operation
- Optional IPMI v1.5 Baseboard Management Controller (BMC) support
- BMC console (text) redirection
- Intel® SpeedStep support
- Optional CompactPCI bus support
- Supports either system board or blade card applications

DUAL ETHERNET INTERFACES - 10/100/1000BASE-T:

An internal 64-bit/ 100MHz PCI-X bus connects to the Intel 82546EB Ethernet controllers, ensuring full-speed Gigabit Ethernet in applications using 1000Base-T Ethernet communications. Channel A on each controller supports 10/ 100/ 1000Base-T Ethernet connectivity to the RJ45 connectors located on the CP16's front panel. Channel B on each controller enables the SBC's Packet Switching Backplane capability.

REAR TRANSITION MODULE (OPTIONAL):

The R1M25 is available for use in CP16 applications where rear access I/O panel connectors are required. The R1M25 is not required for the CP16 to function. The R1M25's optional Ultra320 SCSI interfaces utilize the high-speed, 1GB/s Hub Link 2.0 interface from the CP16's E7501 Memory Controller Hub.



Dependable, always.

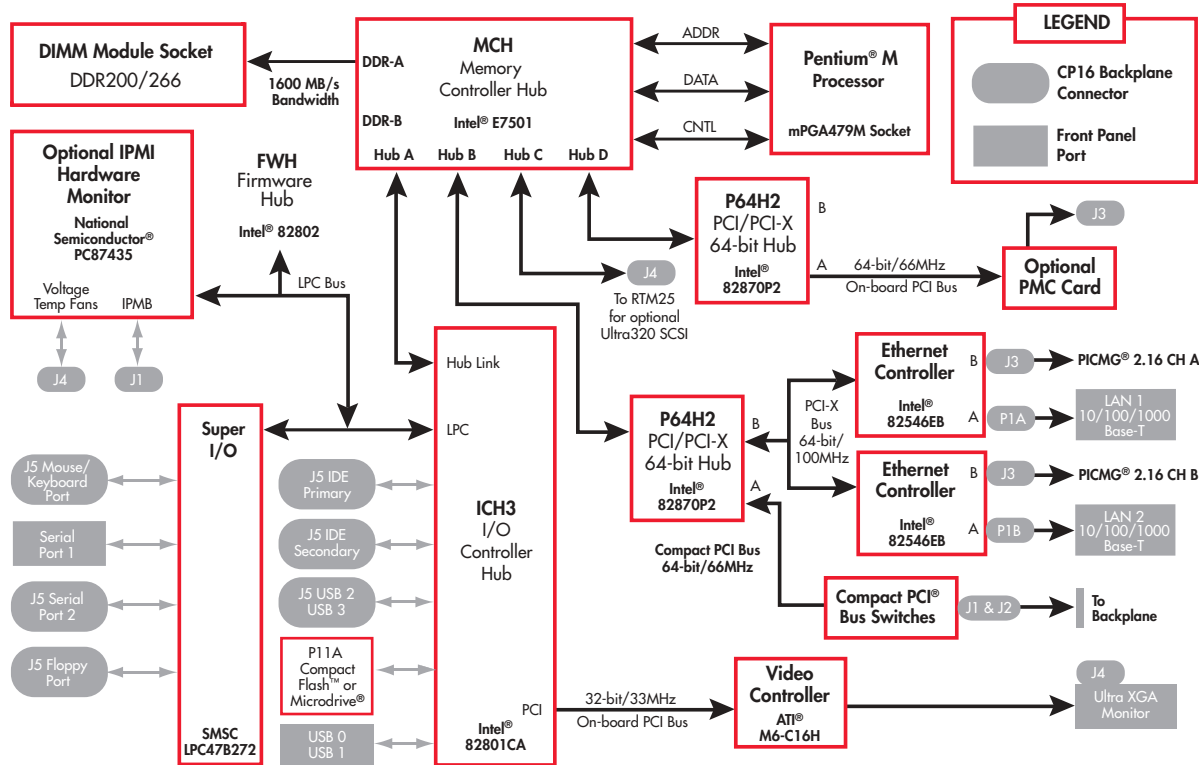

ULTRA XGA INTERFACE:

The ATI® M6-C16H video controller enables 2D/3D video acceleration and provides 16MB of integrated video DDR memory. The video controller supports pixel resolutions up to 1600 x 1200 (UXGA). Software drivers are available for most popular operating systems.

DUAL ULTRA ATA/100 INTERFACES:

Dual high-performance FDI EIDE interfaces are capable of supporting up to two IDE disk drives each in a master/slave configuration. The interfaces support Ultra ATA/100 with synchronous ATA mode transfers up to 100MB per second. The interfaces are routed through backplane connector J5. Dual EIDE connectors are available on the optional RTM25 rear transition module.

DDR200/266 MEMORY:

The CP16 provides a single channel DDR memory interface terminating at a DIMM socket. The memory interface supports up to 2GB of memory and has an interface bandwidth of 1600MB/s. The SBC accepts a single ECC, registered PC1600 or PC2100 DIMM.

UNIVERSAL SERIAL BUS (USB):

A total of four (4) USB ports are available on the CP16. USB ports 0 and 1 are located on the CP16's front panel and USB ports 2 and 3 are available at connector J5. The CP16's E7501 chipset supports USB revision 1.1.

ADDITIONAL CP16 FEATURES:

- Two high-speed serial ports
- PS/2 mouse/keyboard interface via J5
- Floppy drive interface
- Programmable watchdog timer

FORM FACTOR:

The CP16 is a single slot module (4HP width) with a 6U height and is fully compliant with the CompactPCI® Core Specification, FICMG® 2.0, F8.0.

CP16 APPLICATION CONSIDERATIONS:

Power Requirements:

Typical Values

PROCESSOR	+5V	+12V	+3.3V
1.8GHz*	6.25A	0.20A	4.10A
1.8GHz**	4.03A	0.20A	5.96A
1.6GHz*	6.20A	0.20A	3.99A
1.6GHz**	4.00A	0.20A	5.80A

-12V @ <100mA

*5V(I/O) configured backplane

**3.3V(I/O) configured backplane

Temperature/Environment:

Operating Temperature: 0° to 55° C with 350 LFM of airflow

Storage Temperature: -20° to 70° C with 350 LFM of airflow

Humidity: 5% to 90% non-condensing

Cooling Solution: Passive Heat Sink

STANDARDS:

- PCI Local Bus Specification 2.1
- CompactPCI® Core Specification, FICMG® 2.0, F8.0
- CompactPCI® Hot Swap Specification, FICMG® 2.1, F2.0
- CompactPCI® Hot Swap Infrastructure Specification, FICMG® 2.12, F2.0
- CompactPCI® PCI Telecom Mezzanine Card (PTMC) Specification, FICMG® 2.15, F1.0
- CompactPCI® System Management Specification, FICMG® 2.9, F1.0 (Intelligent Platform Management Interface (IPMI) support)
- CompactPCI® Packet Switching Backplane Specification, FICMG 2.16, F1.0

AGENCY APPROVALS:

Designed for UL 1950, CAN/CSA C22.22 Number 950-95, EN5022:1994/A2:1997, CLASS A EN5024, EN61006-2:1999, EN61000-3-2:2001

ORDERING INFORMATION:

Model #	Model Name: CP16 CPU Speed with IPMI	FSB Speed
6137-206-xM	1.8GHz	With J4 I/O
6137-004-xM	1.6GHz	With J4 I/O
6137-246-xM	1.8GHz	Without J4 I/O
6137-044-xM	1.6GHz	Without J4 I/O
	without IPMI	
6137-706-xM	1.8GHz	With J4 I/O
6137-504-xM	1.6GHz	With J4 I/O
6137-746-xM	1.8GHz	Without J4 I/O
6137-544-xM	1.6GHz	Without J4 I/O

(xM = Memory)

Rear Transition Module

with SCSI

6142-000	RTM25	With J4 I/O
6142-020	without SCSI	
6142-040	RTM25-NS	With J4 I/O
	RTM25-NJ	Without J4 I/O

Model Name: OMDC

Model #	Description
6245-000	With Type 2 media connector

Intel, Pentium and SpeedStep are trademarks or registered trademarks of Intel Corporation. All other product names are trademarks of their respective owners.

Copyright ©2004 by TRENTON Technology Inc. All rights reserved.



Dependable, always.

Intel®
Communications
Alliance
Associate Member
SILVER