

FEATURES

- Small Form Factor (SFF) backplane supports one PICMG® 1.3 server-class system host board
- One PCI Express® and two PCI-X option card slots
- PCIe card slot configuration: PCIe x16 mechanical / x16 electrical
- PCI-X card slot configurations: two 64-bit/133MHz
- Optimized for use with Trenton high-performance PICMG 1.3 system host boards
- Four USB 2.0 backplane I/O connections**
- ATX/EPS, +12V AUX vertical and right-angle input power connector configuration options
- Five-year factory warranty
- Made in U. S. A.

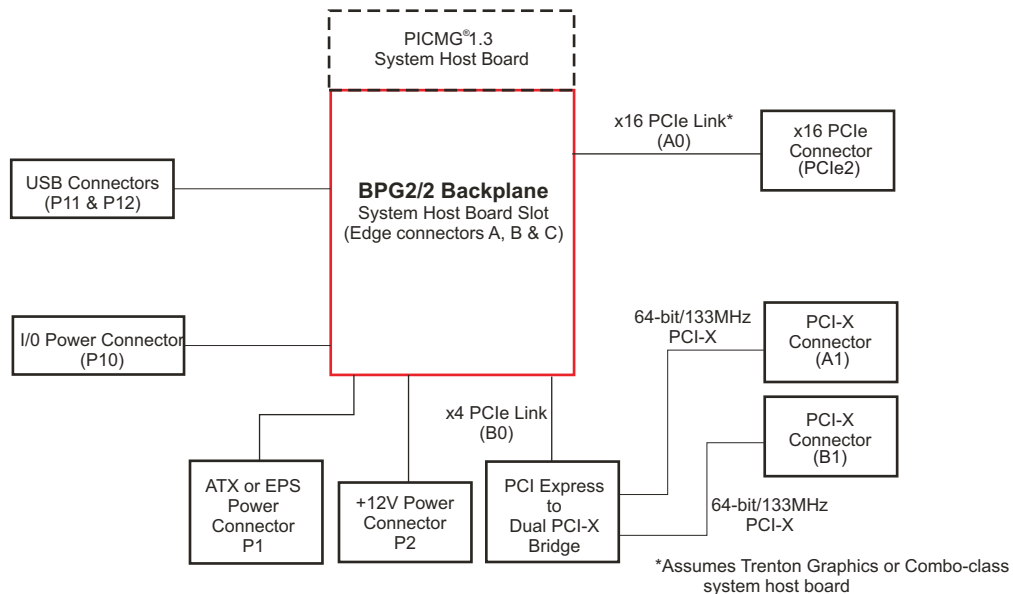

BLOCK DIAGRAM:



SMALL FORM FACTOR PCI EXPRESS BACKPLANE:

The PCI Express® link design of the Trenton BPG2/2 backplane supports PICMG® 1.3 graphics-class SHBs. Card slot PCIe2 is a x16 mechanical slot connected directly to the SHB and driven with a x16 PCIe electrical link. The backplane also includes two 64-bit/133MHz card slots connected to the SHB via a x4 PCI Express link and a PCI Express-to-PCI-X bridge chip. The bridge chip ensures secure data communications between the SHB and the PCI-X/PCI cards. The chip also throttles-down the bus interface speed to match any card placed in either slot A1 or B1 that has an interface bus speed less than 133MHz.

APPLICATION EXAMPLES:

A system design that needs a small form factor (SFF) backplane to fit inside a tight location within a machine such as a medical diagnostic unit or a silicon wafer processing machine are typical applications for the BPG2/2 backplane. COTS option card support for one x16 PCIe video/graphics card and two PCI-X/PCI cards simultaneously is the ideal application scenario for the Trenton BPG2/2 backplane. The backplane's compact, SFF design offers a good blend of serial PCI Express and parallel PCI-X/PCI interconnect technology. This eliminates service interruptions caused by video and graphics cards technology transitions.

BACKPLANE MODEL: BPG2/2

MODEL#	MODEL NAME	DESCRIPTION
6532-007	BPG2/2-CRA	Right-angle ATX/EPS and +12V AUX connectors
6532-008	BPG2/2-CST	Vertical ATX/EPS and +12V AUX connectors

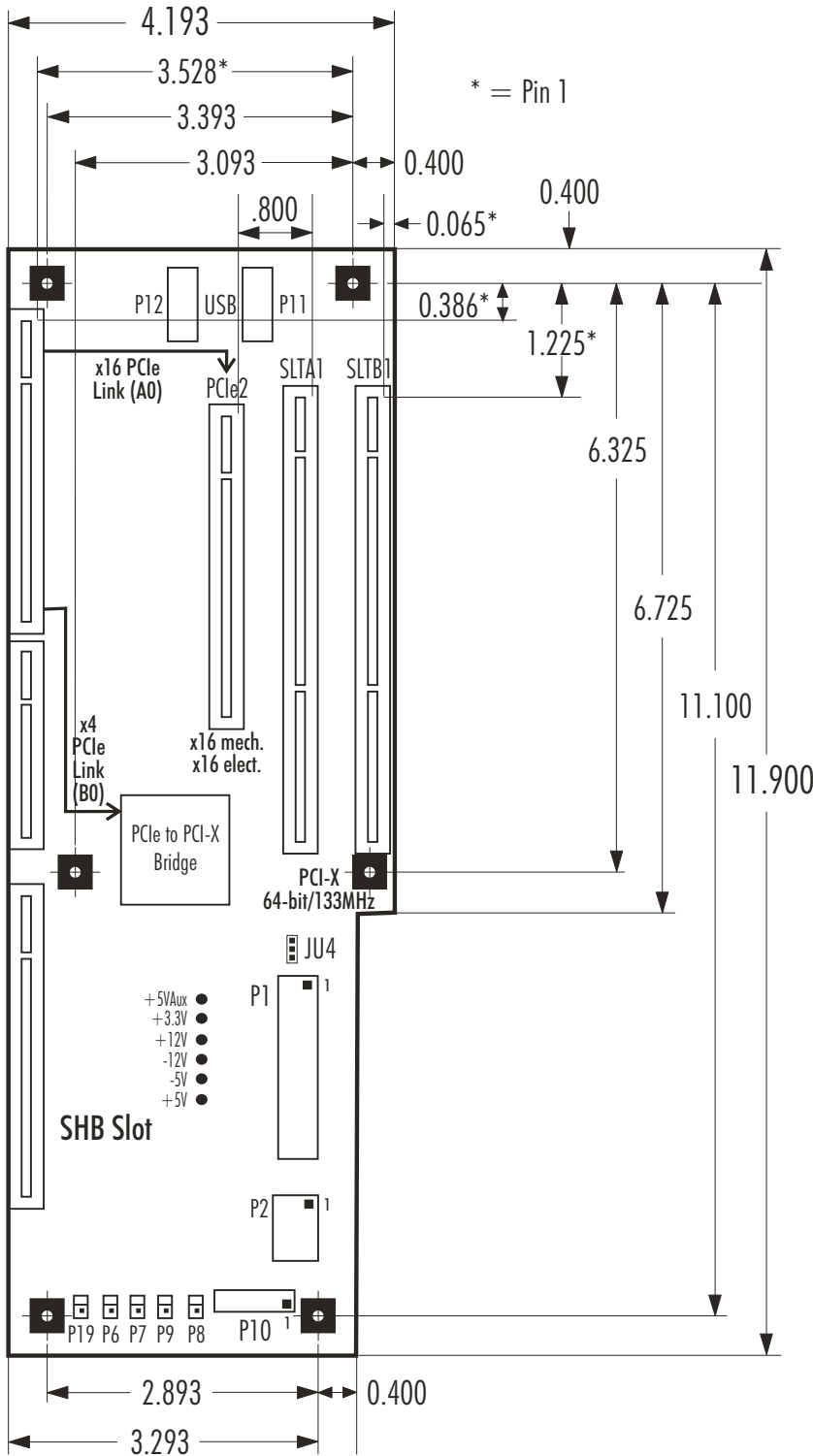

SUGGESTED TRENTON PICMG 1.3 SHBs:
DUAL PROCESSOR SYSTEM HOST BOARDS

BXT7059 JXT6966

SINGLE PROCESSOR SYSTEM HOST BOARDS

TSB7053 TQ9 BXTS7059 JXTS6966

ENVIRONMENTAL SPECIFICATIONS:#

Operating Temp.: 0° C. to 60° C

Storage Temp.: -40° C. to 70° C

Humidity: 5% to 90%, non-condensing

Environmental specifications for system host boards / single board computers are usually lower than those of the backplane. Check with your SHB/SBC vendor.

The Trenton BPG2/2 is a lead-free, RoHS compliant backplane.

This backplane is designed to meet worldwide EMI emissions requirements, CE conformity and immunity standards. Contact Trenton for specific standard numbers.

The Trenton BPG2/2 backplane is designed for UL60950 and CAN/CSA C22.2 No. 60950-00.

Engineering Notes:

All power connectors are shown in the layout drawings. The connectors are populated based on model.

Nominal PCB thickness: 0.062"

Connector spacing: .800" centers – To find the center of a PCI-X/PCI option card connector to the left of the reference dimension hole, add 0.150" to the pin 1 location dimension. To find the center of a PCI Express option card connector and the SHB slot add 0.049" to the pin 1 location dimension.

Mounting holes: 0.156" diameter

All dimensions are inches.

** Optional USB connectivity provided by the PICMG 1.3 System Host Board. Not all SHBs support this capability.

Product Photo Note: The photo of the 6532 backplane shown on page one is provided for illustrative purposes only. Actual connector locations are illustrated in the backplane layout drawings and on the Trenton website.

PICMG is a registered trademark of the PCI Industrial Computer Manufacturers Group. All other product names are trademarks of their respective owners.

Copyright © 2014 by TRENTON Systems, Inc., All rights reserved

