

FEATURES

- Small Form Factor (SFF) backplane supports one PICMG® 1.3 graphics-class system host board
- Three PCI Express® option card slots
- PCIe card slot configurations: one PCIe x16 mechanical / x16 electrical and two PCIe x8 mechanical / x4 electrical*
- Optimized for use with Trenton high-performance PICMG 1.3 system host boards
- Two 10/100/1000Base-T backplane Ethernet ports**
- Four USB 2.0 backplane I/O connections**
- ATX/EPS, + 12V AUX vertical and right-angle input power connector configuration options
- Five-year factory warranty
- Made in U. S. A.

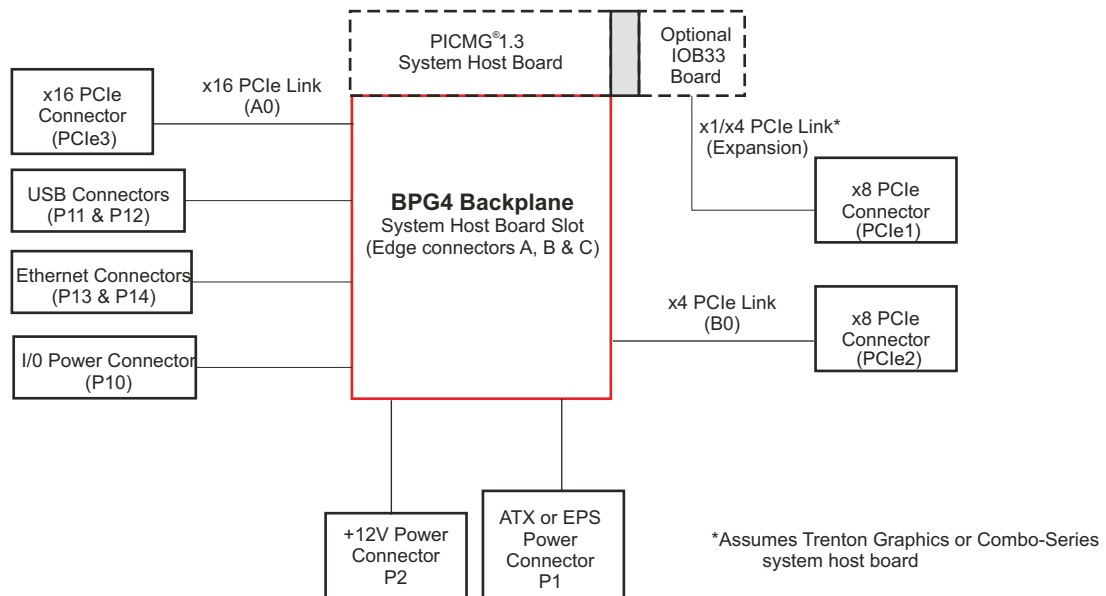

BLOCK DIAGRAM:



SMALL FORM FACTOR PCI EXPRESS BACKPLANE:

The PCI Express® link design of the Trenton BPG4 backplane supports PICMG® 1.3 graphics-class SHBs. On this PCI Express-only backplane, all of the option card slots are connected directly to the system host board ensuring maximum possible PCIe data throughput speeds. Card slot PCIe3 is a x16 mechanical slot connected directly to the SHB and driven with a x16 PCIe electrical link. PCIe1 and PCIe2 are x8 mechanical slots and PCIe2 is driven with a x4 PCIe link directly from the SHB. The PCIe1 slot is driven by a x4 electrical link delivered to the card slot via an IOB33 module installed on a Trenton SHB.

APPLICATION EXAMPLES:

A system design that needs to support multiple PCI Express option cards on a small form factor backplane that can fit inside tight locations within data gathering, diagnostic, mechanical assembly or inspection machines are typical applications for the Trenton BPG4 backplane. The x16 electrical link provided on card slot PCIe3 of the BPG4 backplane supports high-end PCI Express video and graphics cards common in demanding video and graphics applications. The backplane's direct and high-speed PCIe card interconnects ensures that the system's COTS option cards take full advantage of PCI Express technology.

BACKPLANE MODEL: BPG4

MODEL#	MODEL NAME	DESCRIPTION
6537-007	BPG4-CRA	Right-angle ATX/EPS and + 12V AUX connectors
6537-008	BPG4-CST	Vertical ATX/EPS and + 12V AUX connectors

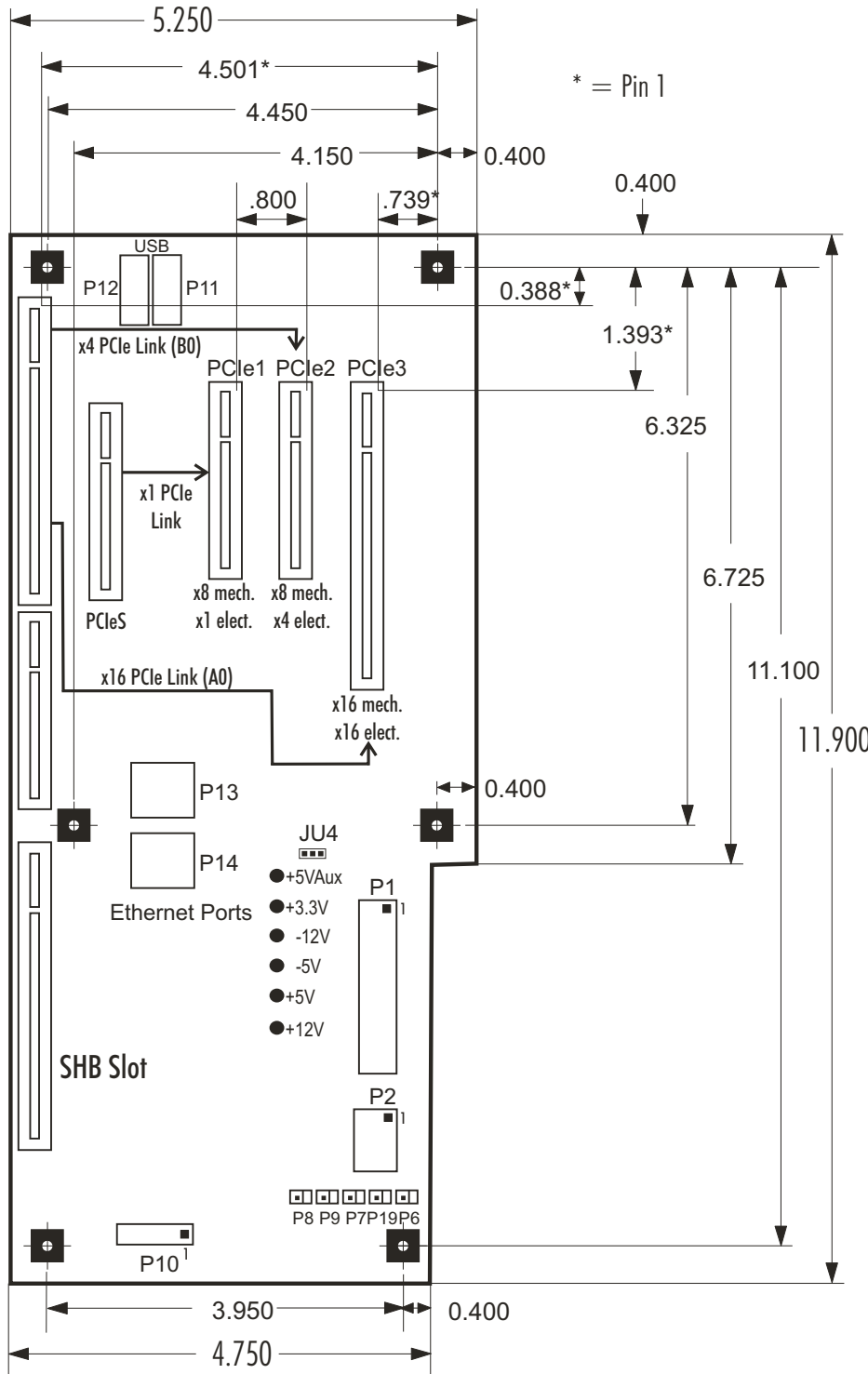

**SUGGESTED TRENTON PICMG 1.3 SHBs:
DUAL PROCESSOR SYSTEM HOST BOARDS**

BXT7059 JXT6966

SINGLE PROCESSOR SYSTEM HOST BOARDS

TSB7053 BXTS7059 JXTS6966 TQ9

ENVIRONMENTAL SPECIFICATIONS:#

Operating Temp.: 0° C. to 60° C
Storage Temp.: -40° C. to 70° C
Humidity: 5% to 90%, non-condensing

Environmental specifications for system host boards / single board computers are usually lower than those of the backplane. Check with your SHB/SBC vendor.

The Trenton BPG4 is a lead-free, RoHS compliant backplane. This backplane is designed to meet worldwide EMI emissions requirements, CE conformity and immunity standards. Contact Trenton for specific standard numbers.

The Trenton BPG4 backplane is designed for UL60950 and CAN/CSA C22.2 No. 60950-00.

Engineering Notes:
All power connectors are shown in the layout drawings. The connectors are populated based on model.

Nominal PCB thickness: 0.062"

Connector spacing: .800" centers – To find the center of a PCI Express option card connector and the SHB slot add 0.049" to the pin 1 location dimension.

Mounting holes: 0.156" diameter

All dimensions are inches.

*PCIe1 slot functionality requires an IOB33 installed on the SHB. Depending on the SHB, the link delivered to the backplane by the IOB33 may be either a x1 or x4 PCIe link.

** Optional USB and Ethernet connectivity provided by the PICMG 1.3 System Host Board. Not all SHBs support this capability.

Product Photo Note: The photo of the 6537 backplane shown on page one is provided for illustrative purposes only. Actual connector locations are illustrated in the backplane layout drawings and on the Trenton website.

PICMG is a registered trademark of the PCI Industrial Computer Manufacturers Group. All other product names are trademarks of their respective owners.

Copyright © 2014 by TRENTON Systems, Inc., All rights reserved

