

# BPG6714

## SMALL FORM FACTOR PCI EXPRESS® BACKPLANE



### FEATURES

- Small Form Factor (SFF) backplane supports one PICMG® 1.3 graphics-class system host board
- Two PCI Express® and three PCI-X option card slots
- PCIe card slot configurations: one PCIe x16 mechanical / x16 electrical and one PCIe x8 mechanical / x4 electrical\*
- PCI-X card slot configurations: one 64-bit/133MHz and two 64-bit/100MHz
- Optimized for use with Trenton high-performance PICMG 1.3 system host boards
- Two 10/100/1000Base-T backplane Ethernet ports\*\*
- Four USB 2.0 backplane I/O connections\*\*
- ATX/EPS, +12V AUX vertical and right-angle input power connector configuration options
- Five-year factory warranty
- Made in U. S. A.



### BLOCK DIAGRAM:

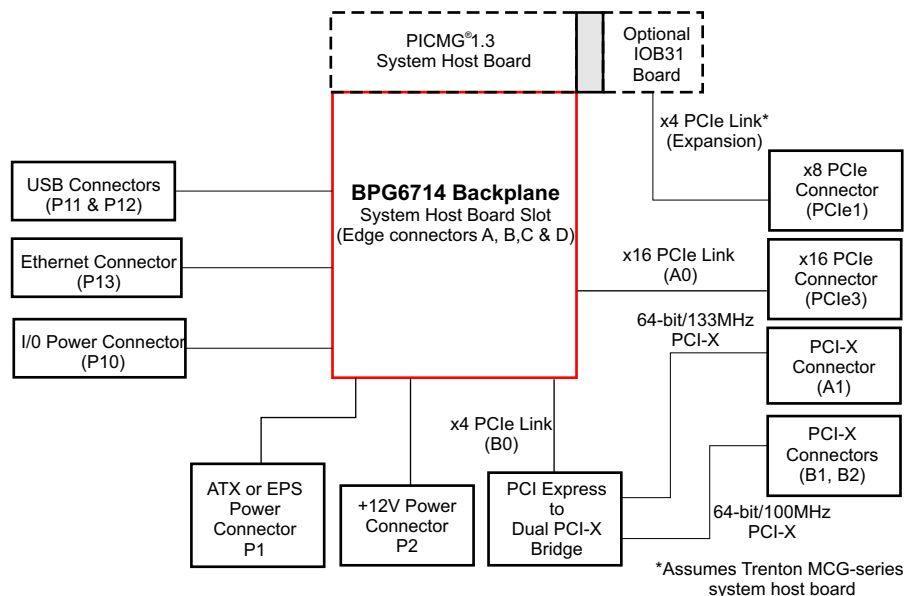

### SMALL FORM FACTOR PCI EXPRESS BACKPLANE:

The PCI Express® link design of the Trenton BPG6714 backplane supports PICMG® 1.3 graphics-class SHBs. Card slot PCIe3 is a x16 mechanical slot that is driven with a x16 electrical link directly from the SHB making it an ideal slot for high-end PCI Express graphics and video cards. PCIe1 is a x8 mechanical slot driven with a x4 electrical link delivered to the card slot via an IOB31 module installed on a Trenton MCG-series SHB. The backplane also includes one 64-bit/133MHz and two 64-bit/100MHz PCI-X card slots. The PCI-X slots are capable of supporting universal, 64 or 32-bit PCI cards.

### APPLICATION EXAMPLES:

A system design that needs a small form factor backplane that can fit inside a tight location within a machine such as a medical diagnostic unit or a machine vision inspection system are typical applications for the Trenton BPG6714 backplane. Applications with very high-end video and graphics requirements such as a x16 PCI Express and a 64-bit/133MHz PCI-X card are ideal application scenarios for the BPG6714 backplane. The backplane's blend of serial PCI Express and parallel PCI-X/PCI interconnect technology eliminates any service interruptions caused by future technology transitions of COTS option card technology.

### BACKPLANE MODEL: BPG6714

MODEL#	MODEL NAME	DESCRIPTION
6714-007	BPG6714-CRA	Right-angle ATX/EPS and +12V AUX connectors
6714-008	BPG6714-CST	Vertical ATX/EPS and +12V AUX connectors

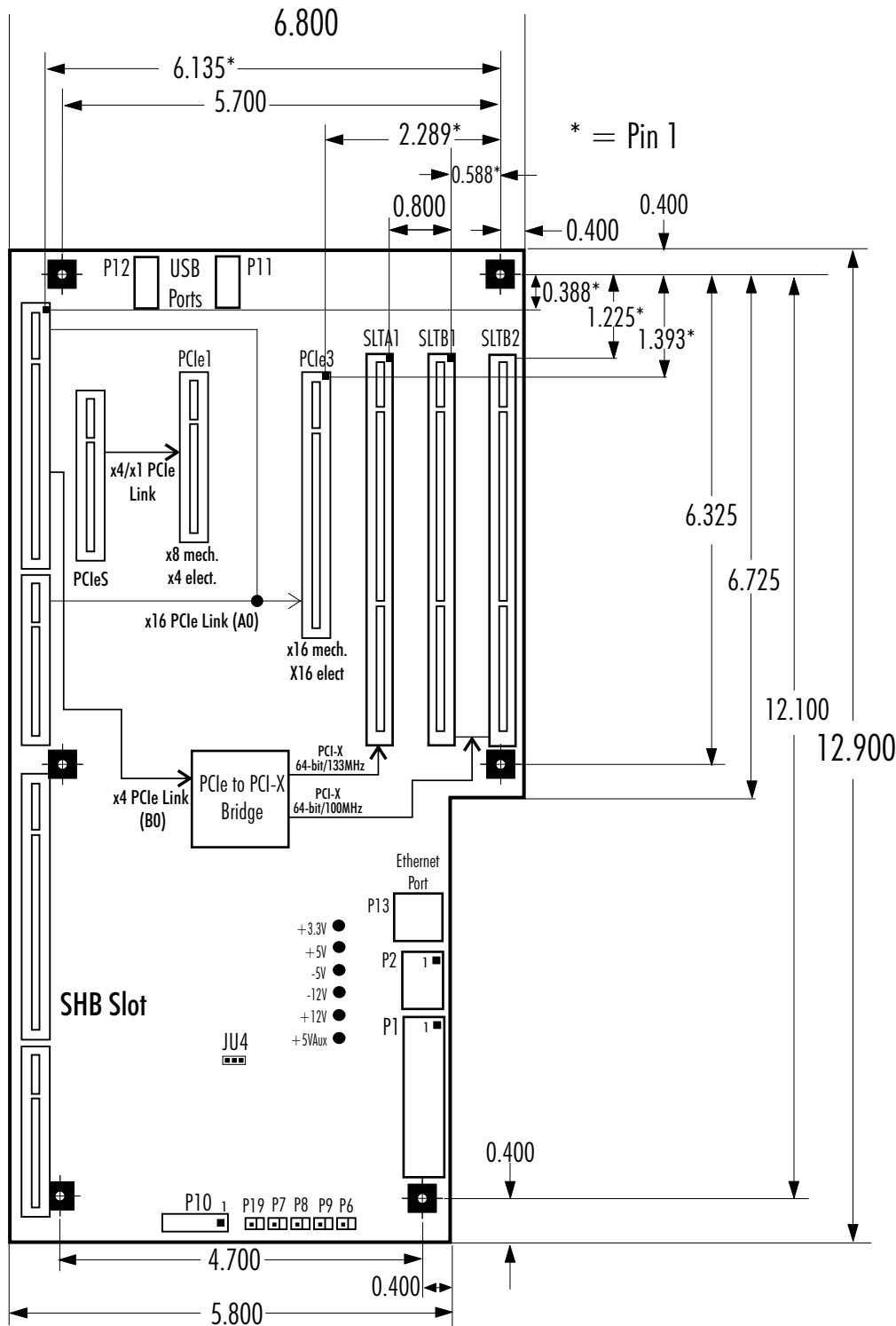

**SUGGESTED TRENTON GRAPHICS**

**CLASS PICMG 1.3 SHBs:**

**DUAL PROCESSOR SYSTEM  
HOST BOARDS**

MCGT MCGT-E

**SINGLE PROCESSOR SYSTEM HOST  
BOARDS**

MCGI TQ9 TML T4L

**ENVIRONMENTAL SPECIFICATIONS:#**

Operating Temp.: 0° C. to 60° C

Storage Temp.: -20° C. to 70° C

Humidity: 5% to 90%, non-condensing

# Environmental specifications for system host boards / single board computers are usually lower than those of the backplane. Check with your SHB/SBC vendor.

The Trenton BPG6714 is a lead-free, RoHS compliant backplane.

This backplane is designed to meet worldwide EMI emissions requirements, CE conformity and immunity standards. Contact Trenton for specific standard numbers.

The Trenton BPG6714 backplane is designed for UL60950 and CAN/CSA C22.2 No. 60950-00.

**Engineering Notes:**

All power connectors are shown in the layout drawings. The connectors are populated based on model.

Nominal PCB thickness: 0.062"

Connector spacing: .800" centers

To find the center of a PCI-X/PCI option card connector to the left of the reference dimension hole, add 0.150" to the pin 1 location dimension.

To find the center of a PCI Express option card connector and the SHB slot add 0.049" to the pin 1 location dimension.

Mounting holes: 0.156" diameter

All dimensions are inches.

\*PCIe1 slot functionality requires an IOB31 installed on the SHB. Trenton MCG-series SHBs deliver a x4 PCIe link, while TQ9, TML and T4L-class of SHBs deliver a x1 PCIe link to the option card slot.

\*\* Optional USB and Ethernet connectivity provided by the PICMG 1.3 System Host Board. Not all SHBs support this capability.

*Product Photo Note: The photo of the 6714 backplane shown on page one is provided for illustrative purposes only. Actual connector locations are illustrated in the backplane layout drawings and on the Trenton website.*

PICMG is a registered trademark of the PCI Industrial Computer Manufacturers Group. All other product names are trademarks of their respective owners.

Copyright ©2009 by TRENTON Technology Inc.

All rights reserved

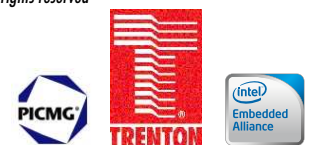

Dependable, always.