

BP6FS6605

SIX-SEGMENT PCI EXPRESS BACKPLANE



Model number 6605-136 shown*

FEATURES

- 20-slot form factor supports up to six PICMG[®] 1.3 graphic-class or server-class system host boards (SHBs)
- One x16 PCI Express[®] mechanical slot per segment
- Three segments offer an additional x8 mechanical slot
- Optimized for use with Trenton SLT and SLI server-class or Trenton TML graphics-class PICMG 1.3 system host boards
- Available in stand-alone or Ethernet fabric configurations
- Ideal for cluster computing system applications with low-profile SHBs
- ATX/EPS and +12V AUX power connector option
- +12V terminal block connector option in which +5 and +3.3 voltage levels are generated in each SHB segment of the backplane
- Five-year factory warranty
- Made in U. S. A.



TRENTON
Dependable, always.

BLOCK DIAGRAMS:

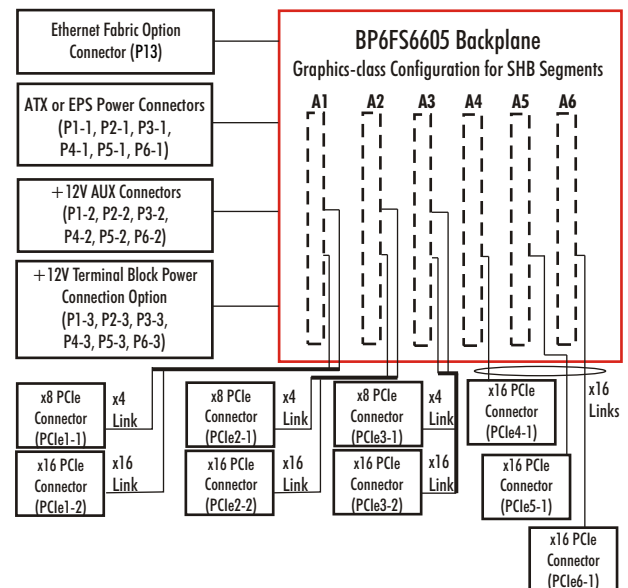
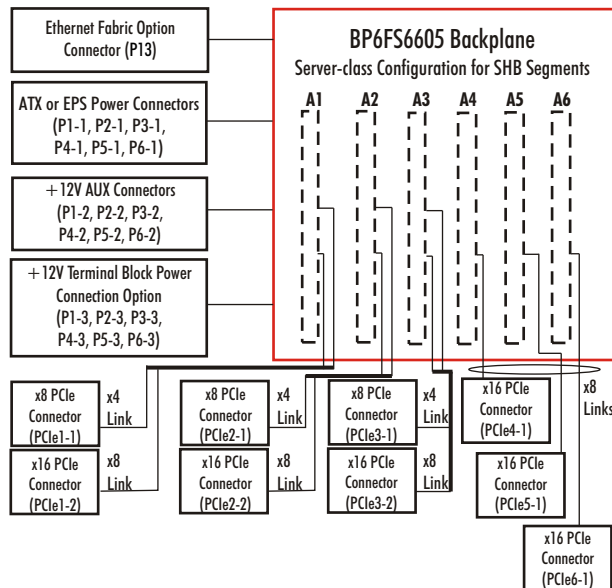

SIX-SEGMENT PCI EXPRESS BACKPLANE:

The six system host board (SHB) segments on the Trenton BP6FS6605 backplane are flexible enough to be ordered in either a graphics-class or server-class configuration. Each segment supports either a low-profile graphics-class or server-class SHB and one or two PCI Express option card slots. Backplane versions are available that enable the SHB segments to operate independently or as part of the backplane's Ethernet fabric network. Additional backplane ordering options are available that allow the segments to have power applied using either standard ATX/EPS power connectors or terminal blocks.

APPLICATION EXAMPLES:

Cluster computing applications that require the processing capabilities of several single or dual processor single board computers working independently or as part of the backplanes optional Ethernet fabric network and housed in a rugged 4U, 19" rackmount chassis are typical system configurations for the backplane. A few application examples for the six segment backplane include cryptography, aircraft communications and control, missile telemetry, complex fabrication machines used in silicon wafer processing, oil and mineral exploration and automatic toll-booths.

BACKPLANE MODEL: BP6FS6605

MODEL#	MODEL NAME	DESCRIPTION -- SERVER-CLASS CONFIGURATIONS
6605-005	BP6FS6605-SCSV	Server-class, Standalone Communications, Vertical EPS/ATX and +12V AUX connectors
6605-016	BP6FS6605-SCST	Server-class, Standalone Communications, +12V Terminal Block connectors
6605-025	BP6FS6605-SCEV	Server-class, Ethernet Fabric Communications, Vertical EPS/ATX and +12V AUX connectors
6605-036	BP6FS6605-SCET	Server-class, Ethernet Fabric Communications, +12V Terminal Block connectors
MODEL#	MODEL NAME	DESCRIPTION -- GRAPHICS-CLASS CONFIGURATIONS
6605-105	BP6FS6605-GCSV	Graphics-class, Standalone Communications, Vertical EPS/ATX and +12V AUX connectors
6605-116	BP6FS6605-GCST	Graphics-class, Standalone Communications, +12V Terminal Block connectors
6605-125	BP6FS6605-GCEV	Graphics-class, Ethernet Fabric Communications, Vertical EPS/ATX and +12V AUX connectors
6605-136	BP6FS6605-GCET	Graphics-class, Ethernet Fabric Communications, +12V Terminal Block connectors

BP6FS6605 LAYOUT - SERVER-CLASS CONFIGURATION

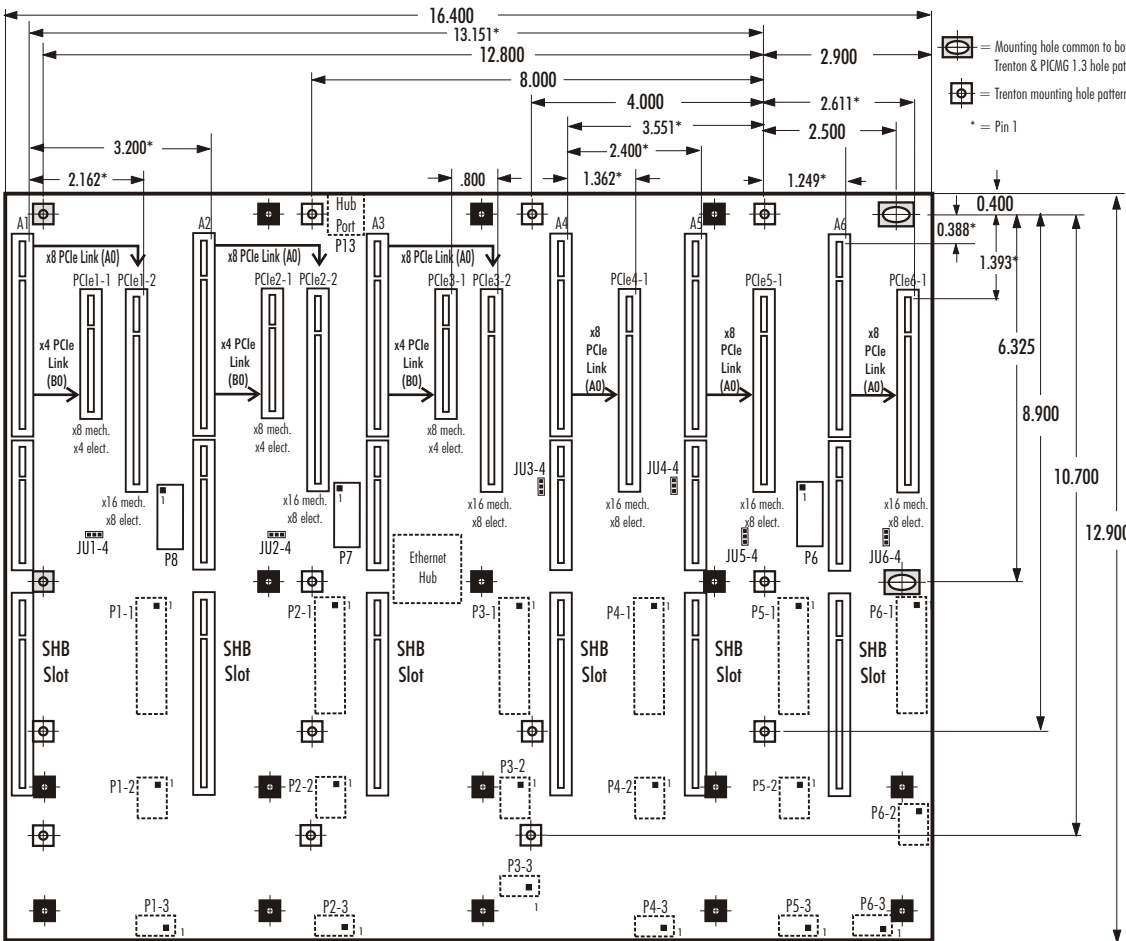

**SUGGESTED SERVER-CLASS
TRENTON PICMG 1.3 SHBs:
DUAL PROCESSOR SYSTEM
HOST BOARD
SLT**

**SINGLE PROCESSOR SYSTEM
HOST BOARD
SLI**

Note: The optional PICMG 1.3 Ethernet edge connector interface to the backplane is not supported on the Trenton SLT and SLI system host boards.

Notes: Dotted lines indicate connectors and other components that are populated based on model name and number. Typical PCIe connector centers are 0.049" from pin 1. Mounting holes: 0.156" diameter. Nominal PCB thickness: 0.080". All dimensions are inches.

*NOTE: The photo of the 6605 backplane shown on page one is provided for illustrative purposes only. Actual connector locations are illustrated in the backplane layout drawings and on the Trenton website.

PICMG is a registered trademark of the PCI Industrial Computer Manufacturers Group. All other product names are trademarks of their respective owners.

BP6FS6605 LAYOUT - GRAPHICS-CLASS CONFIGURATION:

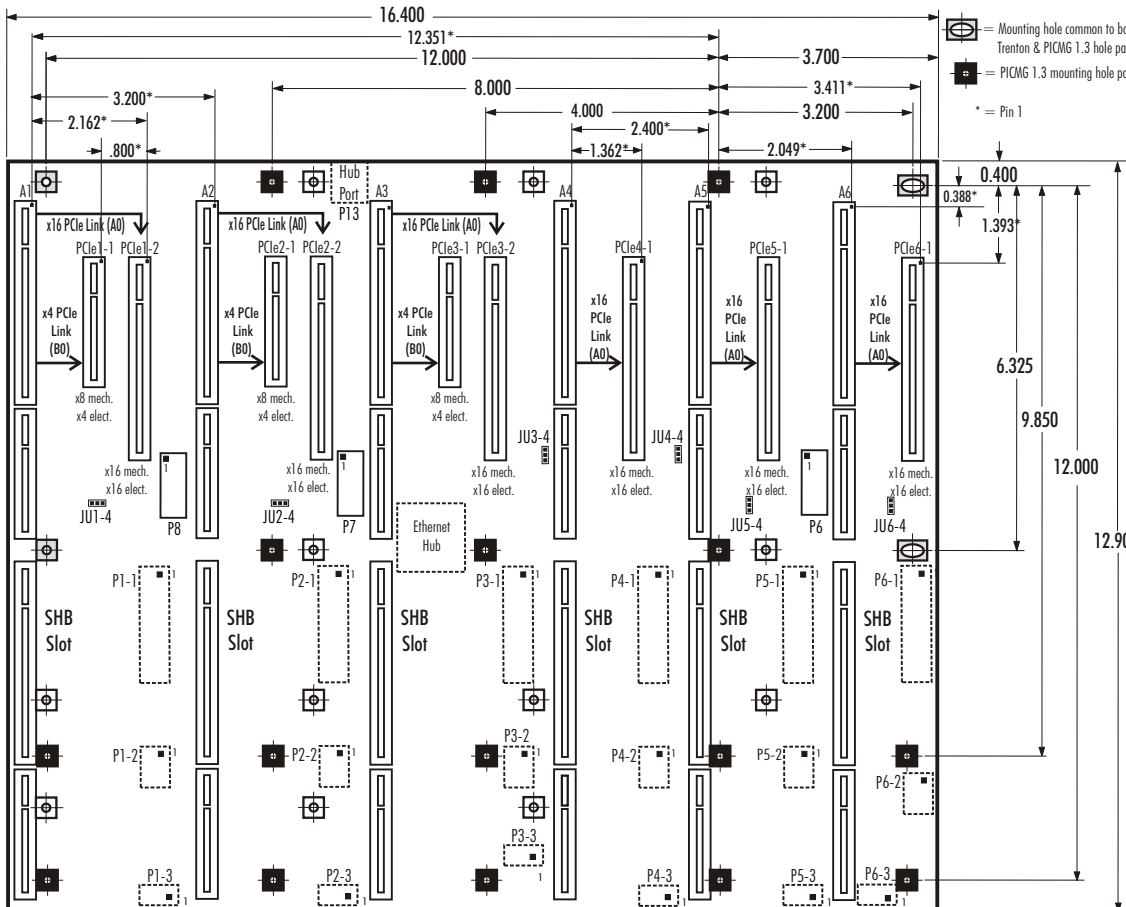

**SUGGESTED GRAPHICS-CLASS
TRENTON PICMG 1.3 SHB:
SINGLE PROCESSOR SYSTEM
HOST BOARD
TML**

ENVIRONMENTAL SPECS.:

Operating Temp.: 0° C. to 60° C
Storage Temp.: -40° C. to 70° C
Humidity: 5% to 90%, non-condensing

The Trenton BP6FS6605 is a lead-free, RoHS compliant backplane.

This backplane is designed to meet worldwide EMI emissions requirements, CE conformity and immunity standards. Contact Trenton for the specific standard numbers this product.

The Trenton BP6FS6605 backplane is designed for UL60950 and CAN/CSA C22.2 No. 60950-00.

Copyright ©2009 by TRENTON Technology Inc. All rights reserved

