

BPX8093

PCI EXPRESS GEN 3 BACKPLANE

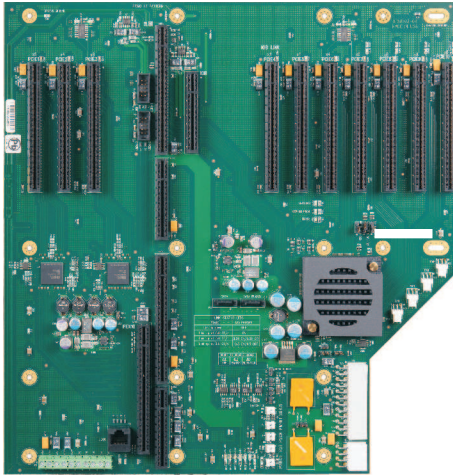

FEATURES

- 14-slot form factor supports one PICMG® 1.3 system host board
- Ideal for dual-processor Trenton BXT7059 system host boards
- Supports industry standard PCI Express® Gen 3.0, 2.0 and Gen 1.1 option cards
- Ten x16 PCI Express mechanical card slots
- PCIe card slot electrical configuration: Six (6) PCIe x8 and four (4) PCIe x4
- Offers seamless PCI Express 3.0 operations when using a BXT7059 SHB**
- One 10/100/1000Base-T backplane Ethernet port**
- Four USB 2.0 and two SATA/300 backplane I/O connections**
- ATX/EPS, +12V AUX and terminal block input power connectors
- Five-year factory warranty
- Made in U. S. A.



BLOCK DIAGRAM:

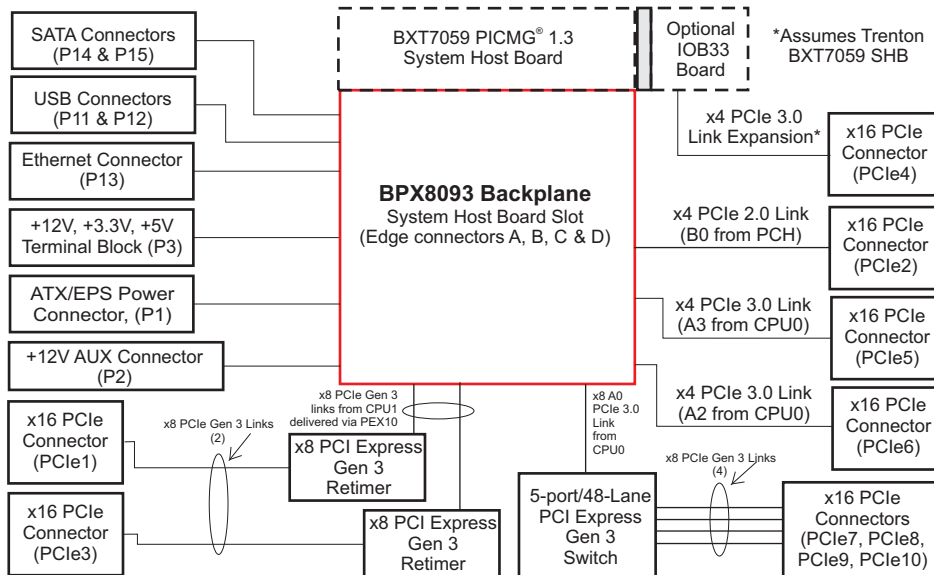

PCI EXPRESS Gen 3 BACKPLANE:

The PCIe 3.0 link design of the BPX8093 backplane supports PCIe Gen 3 links from Trenton's BXT7059 system host board. The backplane's 5-port/48-Lane Gen 3 switch delivers PCIe 3.0 links to option card slots PCIe7, 8, 9 and 10. Direct Gen 3 links from the BXT7059 board are routed to card slots PCIe1, 3, 5 and 6 while PCIe2 is driven with a PCIe 2.0 link. Both the switch and the BXT7059 automatically establish communications with either PCI Express 3.0, 2.0 or 1.1 option cards. All option card slots utilize x16 mechanical connectors and slots PCIe1, 3, 7, 8, 9 and 10 are driven with x8 electrical links while card slots PCIe2, 4, 5 and 6 are driven with x4 links. PCIe4 is a slot driven with a x4 link from the BXT7059's IOB33 expansion board and slots PCIe 1 and 3 require the PEX10 plug in board to receive the PCIe links from SHB's CPU1. The BPX8093 backplane has right angle ATX/EPS and 12V AUX power connectors plus a terminal block to meet expanded system power demands.

APPLICATION EXAMPLES:

Any system design that deploys the latest PCI Express option cards is a good candidate for the BPX8093 backplane. The ability of the backplane to automatically support either PCI Express 3.0, 2.0 or 1.1 cards builds an element of scalability into any COTS rackmount computer design. The backplane brings the added value of flexibility to the system by supporting many different types of PCI Express option cards. The backplane's smaller 14-slot form factor lends itself well to medical diagnostics, military/aerospace, and communication system designs. The slot support of the backplane enables system designs that can grow and adapt to changing requirements without incurring significant system upgrade expense. The BPX8093's ability to support up to ten PCI Express COTS cards, coupled with the backplane's advanced PCI Express 3.0 features enable system designs that offer robust data communications with maximum PCI Express option card flexibility.

BACKPLANE MODEL: BPX8093

MODEL#	MODEL NAME	DESCRIPTION
8093-007	BPX8093-CRA	ATX/EPS and 12V AUX right-angle power connectors, one terminal block

BPX8093 LAYOUT & MOUNTING HOLE PATTERN DIMENSIONS:

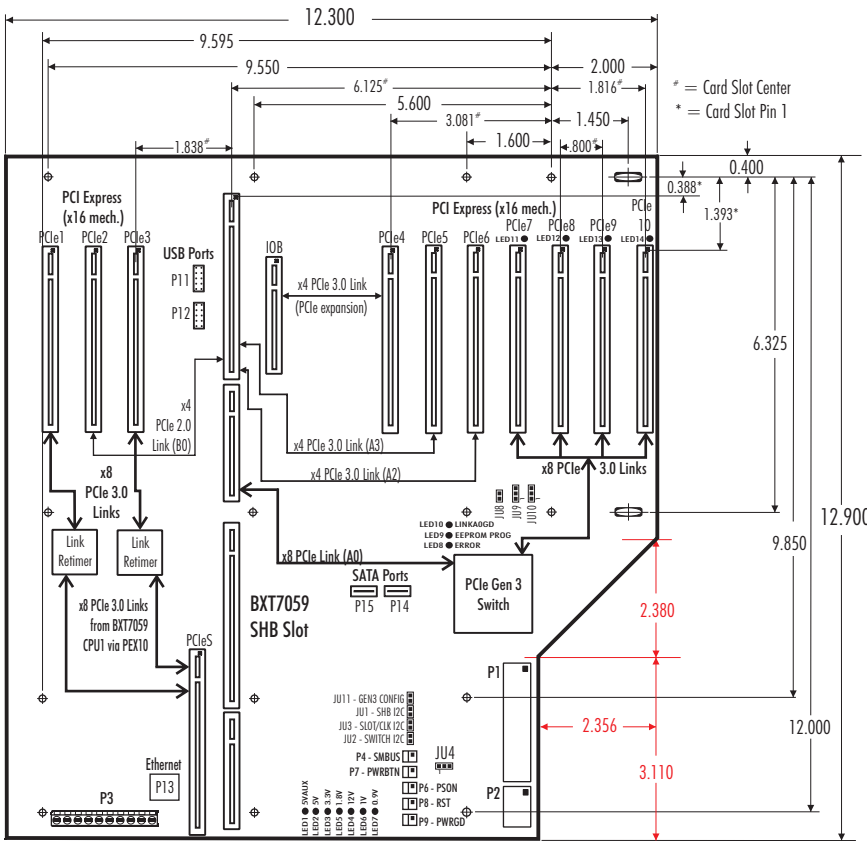

**SUGGESTED TRENTON PICMG 1.3 SYSTEM HOST BOARD:
DUAL PROCESSOR SYSTEM HOST BOARD: BXT7059**

ENVIRONMENTAL SPECS.:#

Operating Temp.: 0° C to 60° C

Storage Temp.: -40° C to 70° C

Humidity: 5% to 90%, non-condensing

Environmental specifications for system host boards / single board computers are usually lower than those of the backplane. Check with your SHB/SBC vendor.

The Trenton BPX8093 is a lead-free, RoHS compliant backplane.

This backplane is designed to meet worldwide EMI emissions requirements, CE conformity and immunity standards. Contact Trenton for the specific standard numbers this product.

The Trenton BPX8093 backplane is designed for UL60950 and CAN/CSA C22.2 No. 60950-00.

ENGINEERING NOTES:

1. The power connectors are shown in the layout drawing represents backplane model number 8093-007.
2. Mounting holes: 0.156" diameter
3. Nominal PCB thickness: 0.080"
4. All dimensions are inches.
5. ** (from page one) The PCI Express 3.0 links and the optional USB, SATA and Ethernet connectivity is provided by the BXT7059 PICMG 1.3 System Host Board. Not all SHBs support these capabilities.

PCI EXPRESS 3.0 LINK STATUS LEDs:

The BPX8093 provides five PCI Express link status LEDs to provide a visual check on the operational speed of the backplane's critical PCI Express links. The links monitored by the LEDs include A0 from the SHB to the 5-port / 48-lane PCI Express Gen 3 and the links routed to card slots PCIe 7, 8, 9 and 10. The possible status states of the multi-purpose LEDs are illustrated in the table below.

- PCI Express Link Status LEDs - LED10, 11, 12,13 and 14 -

State	LED Pattern
Link is down	Off
Link is up at 8.0 GT/s (PCIe 3.0)	On
Link is up at 5.0 GT/s (PCIe 2.0)	0.25s On / 0.25s Off
Link is up at 2/5 GT/s (PCIe 1.1)	0.5s On / 0.5s Off

BACKPLANE JUMPER SETTINGS:

The BPX8093 jumpers are for the most part used during the manufacturing and test of the backplane and have no operational value in most system applications. However, JU4 is the exception to this general rule. JU4 is a +5VAUX jumper that offers a way around the lack of a of the required +5VAUX voltage needed by the SHB in those system configurations using non-ATX/EPS power supplies. Here are the jumper default settings:

Jumper	Function	Pins To Short
JU1	SHB I2C Bus	Leave Open, Do No Populate Jumper
JU2	PCIe Switch I2C Bus	Leave Open, Do No Populate Jumper
JU3	Slot/Clock I2C Bus	Leave Open, Do No Populate Jumper
JU4	+5VAUX Source	ATX/EPS supply, Jumper Pins 2-3
JU8	PCIe Switch (u31) Config.	Jumper Pins 1-2
JU9	PCIe Switch (u31) I2C Bus	Jumper Pins 2-3
JU10	PCIe Switch (u31) GEN	Jumper Pins 1-2
JU11	GEN3 Configuration	Leave Open, Do No Populate Jumper

Product Photo Note: The photo of the BPX8093 backplane shown on page one is a provided for illustrative purposes only. Actual connector and mounting locations are illustrated in the backplane layout drawing.

PICMG is a registered trademark of the PCI Industrial Computer Manufacturers Group. All other product names are trademarks of their respective owners.

Copyright ©2013 by TRENTON Systems Inc. All rights reserved

