

BPG8150

SMALL FORM FACTOR PCIe GEN3 BACKPLANE

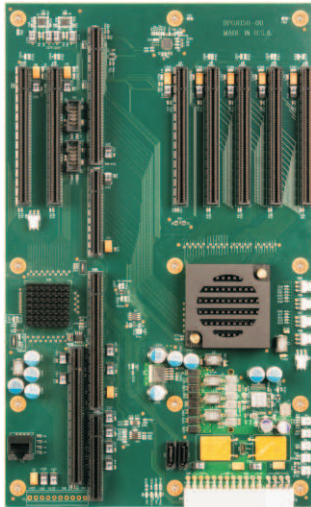

FEATURES

- Small form factor backplane supports one dual-processor PICMG® 1.3 SHB and up to seven PCI Express I/O cards
- Fully compatible with the dual-processor Trenton BXT7059 and other DP PCIe 3.0 SHBs
- Ideal for industry standard PCI Express® 3.0, 2.0 and 1.1 option cards including high-performance video and graphics cards plus GPUs
- Seven x16 PCI Express mechanical card slots
- PCIe card slot electrical configuration: four x16, two PCIe x8 and one PCIe x4
- Offers seamless PCI Express 3.0 operations when using a BXT7059 system host board
- One 10/100/1000Base-T backplane Ethernet port**
- Four USB 2.0 and two SATA/300 backplane I/O connections**
- ATX/EPS, +12V AUX and terminal block input power connectors
- Five-year factory warranty
- Made in U. S. A.



BLOCK DIAGRAM:

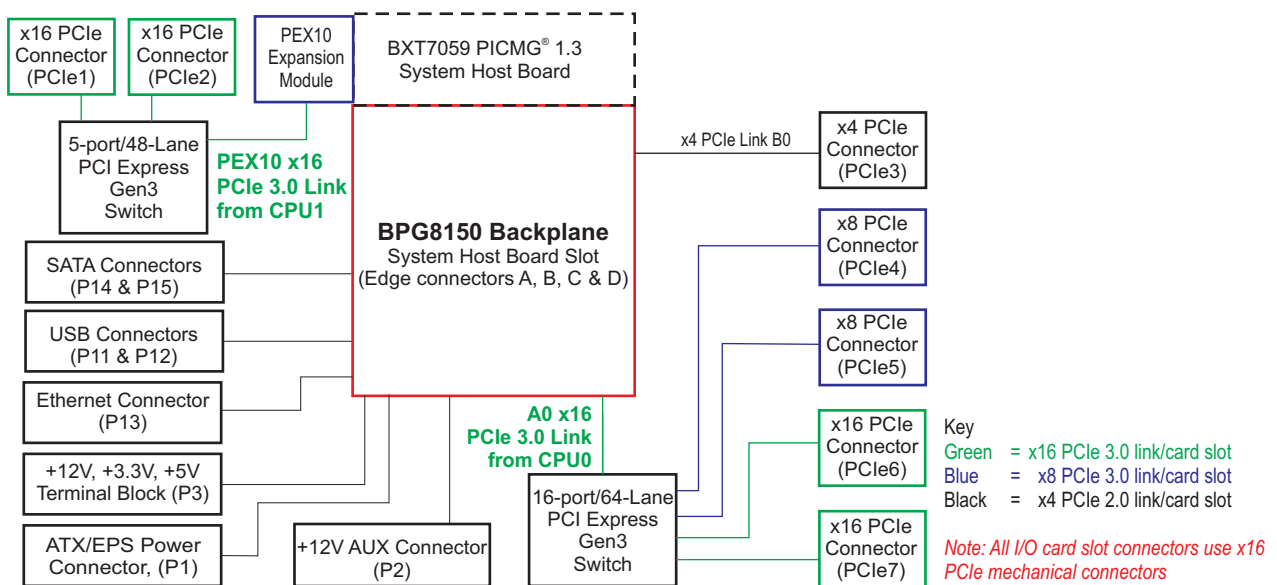

SMALL FORM FACTOR PCI EXPRESS Gen3 BACKPLANE:

The small form factor and the PCIe 3.0 link design of the BPG8150 backplane supports two x16 PCIe Gen3 links from Trenton's current BXT7059 system host board with the PEX10 PCIe link expansion option card installed. Future PCIe Gen3 PICMG 1.3 SHBs from Trenton will also be compatible with this backplane. The backplane's two, PCIe Gen3 switches deliver PCIe 3.0 links to all option card slots except PCIe3. Slot PCIe3 is driven with PCIe 2.0 B0 link from the BXT7059 SHB. This may be a Gen3 link in future SHBs. Both the switches and the BXT7059 automatically establish communications with either PCI Express 3.0, 2.0 or 1.1 option cards. All option card slots utilize x16 mechanical connectors. Card slots PCIe1, 2, 6 and 7 are driven with x16 electrical links while card slots PCIe4 and 5 are driven with x8 electrical links. PCIe3 is a slot driven with a x4 interface from the BXT7059's B0 link. The BPG8150 backplane has a right angle ATX/EPS and 12V AUX power connector plus an optional terminal block is available to meet expanded system power demands.

APPLICATION EXAMPLES:

The BPG8150's small form factor design enables the placement of two backplanes in a 5U rackmount computer; as well as one backplane in smaller custom enclosures and just about any 4U rackmount chassis. The ability of the backplane to automatically support either PCIe 3.0, 2.0 or 1.1 cards builds an element of scalability into any COTS system design. Any system design deploying the latest PCI Express, I/O, video, graphics or GPU cards is a good candidate for the BPG8150 backplane. The backplane's small form factor lends itself well to medical diagnostics, military/aerospace, video display wall controllers and communication system designs. The diverse slot support designed into the backplane enables system designs that can grow and adapt to changing requirements without incurring significant system upgrade expense. The BPG8150's ability to support up to seven total cards; with four of the card slots driven by x16 PCIe Gen3 interfaces, maximizes system design flexibility, scalability while enabling robust data communications with standard COTS cards.

BACKPLANE MODEL: BPG8150

| MODEL# | MODEL NAME | DESCRIPTION |
|----------|-------------|---|
| 8150-007 | BPG8150-CRA | One ATX/EPS and one 12V AUX right-angle power connector |

BPG8150 LAYOUT & MOUNTING HOLE PATTERN DIMENSIONS:

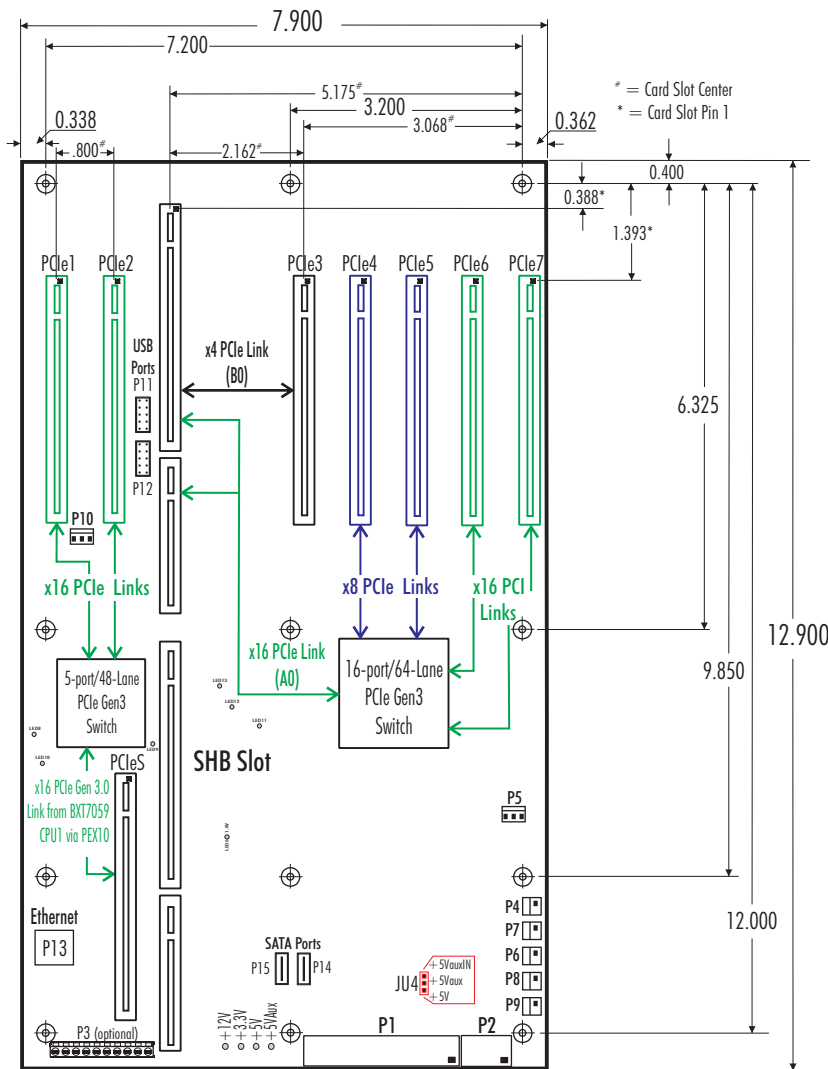

SUGGESTED TRENTON PICMG 1.3 SYSTEM HOST BOARD: DUAL PROCESSOR SYSTEM HOST BOARD: BXT7059

ENVIRONMENTAL SPECS.:#

Operating Temp.: 0° C to 60° C

Storage Temp.: -40° C to 70° C

Humidity: 5% to 90%, non-condensing

*Environmental specifications for system host boards / single board computers are usually lower than those of the backplane. Check with your SHB/SBC vendor.

The Trenton BPG8150 is a lead-free, RoHS compliant backplane.

This backplane is designed to meet worldwide EMI emissions requirements, CE conformity and immunity standards. Contact Trenton for the specific standard numbers this product.

The Trenton BPG8150 backplane is designed for UL60950 and CAN/CSA C22.2 No. 60950-00.

ENGINEERING NOTES:

1. The power connectors are shown in the layout drawing represents backplane model number 8150-007 with terminal block P3 unpopulated.
2. Mounting holes: 0.156" diameter
3. Nominal PCB thickness: 0.080"
4. All dimensions are inches.
5. ** (from page one) The PCI Express 3.0 links and the optional USB, SATA and Ethernet connectivity is provided by the BXT7059 PICMG 1.3 System Host Board. Not all SHBs support these capabilities.
6. PCIe electrical interface key for the option card slots:
 Green = Slot driven with a x16 PCIe 3.0 link
 Blue = Slot driven with a x8 PCIe 3.0 link/card slot
 Black = Slot driven with a x4 PCIe 2.0 link/card slot
7. If a single processor SHB like the Trenton TSB7053 is used in the SHB slot, I/O card slots PCIe1 and PCIe2 will be unavailable.

PCI EXPRESS 3.0 LINK STATUS LEDs:

The BPG8150 provides two PCI Express link status LEDs to provide a visual check on the operational speed of the backplane's critical PCI Express links. The links monitored by the LEDs include A0 from the SHB's CPU0 processor to the 16-port/64-lane PCI Express Gen3 and the PEX10 x16 link routed from the SHB's CPU1 processor to the 12-port/48-lane PCIe Gen3 switch. The possible status states of these two multi-purpose LEDs are illustrated in the table below.

- PCI Express Link Status LEDs - LED10 and LED13 -

| State | LED Pattern |
|-----------------------------------|----------------------|
| Link is down | Off |
| Link is up at 8.0 GT/s (PCIe 3.0) | On |
| Link is up at 5.0 GT/s (PCIe 2.0) | 0.25s On / 0.25s Off |
| Link is up at 2.5 GT/s (PCIe 1.1) | 0.5s On / 0.5s Off |

Ju4 BACKPLANE JUMPER SETTINGS:

The factory default setting for the JU4 jumper connects the TOP pins 2-3 together; these are the two jumper pins closest to the I/O card slots. This jumper setting is used if the +5V auxiliary voltage is provided by a separate +5VAUX signal input pin from standard ATX or EPS power supplies. This enables the necessary SHB power signaling and allows system recovery from a sleep mode event. The JU4 +5VAUX jumper also offers a way around the lack of a of the required +5VAUX voltage needed by the SHB in those system configurations using non-ATX/EPS power supplies. In this case the jumper would be moved to the BOTTOM position to connect pins 1 and 2 together.

| Jumper | Function | Pins To Short |
|--------|---------------|---------------------------------|
| JU4 | +5VAUX Source | ATX/EPS supply, Jumper Pins 2-3 |

Product Photo Note: The photo of the BPG8150 backplane shown on page one is a provided for illustrative purposes only. Actual connector and mounting locations are illustrated in the backplane layout drawing.

PICMG is a registered trademark of the PCI Industrial Computer Manufacturers Group. All other product names are trademarks of their respective owners.

Copyright ©2014 by TRENTON Systems Inc. All rights reserved

