

BPC8219

PCI EXPRESS 2U BACKPLANE

BPC8219 - Side A

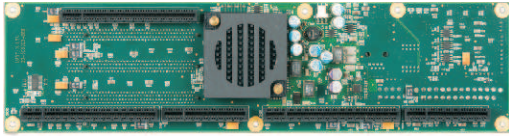

BPC8219 - Side B

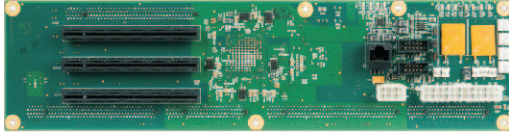

FEATURES

- Butterfly form factor backplane designed for 2U rackmount chassis
- Supports one PICMG® 1.3 system host board
- Ideal for dual-processor Trenton BXT7059 and other PCI Express® system host boards
- 16-Port/64-Lane PCIe Gen2 switch supports industry standard PCI Express I/O cards
- Four x16 PCI Express mechanical card slots
- PCIe card slot electrical configuration: three x16 PCIe 2.0 card interfaces and one x4
- One 10/100/1000Base-T backplane Ethernet port**
- Four USB 2.0 and two SATA/300 backplane I/O connections**
- Vertical ATX/EPS and +12V AUX input power connectors
- Five-year factory warranty
- Made in U. S. A.



BLOCK DIAGRAM:

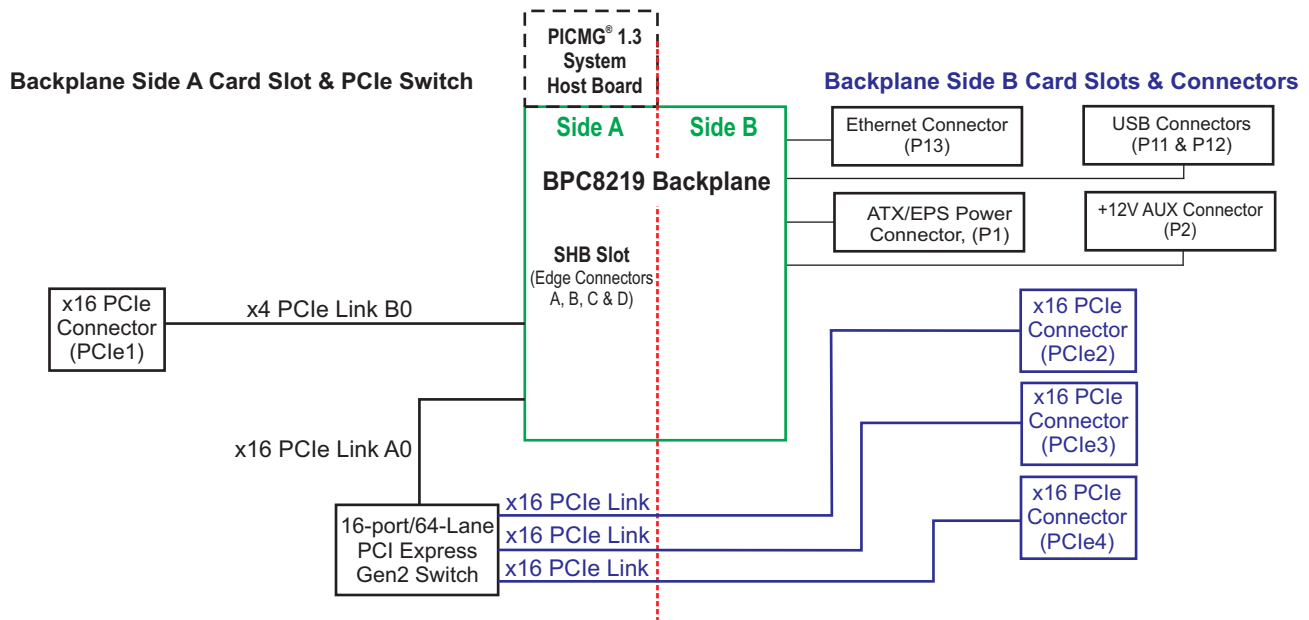

PCI EXPRESS 2U BACKPLANE:

The PCI Express link design of the BPC8219 2U butterfly backplane supports three x16 PCIe Gen2 links out of a 16-port/64-lane PCI Express 2.0 switch. The x16 root link that drives the switch comes from any standard PICMG 1.3 system host board such as Trenton's dual-processor BXT7059 or single-processor TSB7053. The backplane's three x16 PCIe Gen2 links drive the backplane's side B card slots: PCIe2, PCIe3, and PCIe4. The PCIe1 card slot on side A is driven with the SHB's x4 PCIe link B0. When used with Trenton SHB's, all four PCIe backplane interfaces automatically establish communications with either PCI Express 3.0, 2.0 or 1.1 option cards. All option card slots utilize x16 mechanical connectors thereby providing an increased level of 2U rackmount computer application flexibility. The BPC8219 backplane uses vertical ATX/EPS and 12V AUX power connectors in order to simplify the cable harness design and to enable optimal airflow within a 2U rackmount chassis.

APPLICATION EXAMPLES:

Any 2U rackmount computer design deploying the latest x16 PCIe option cards is a good candidate for the BPC8219 backplane. The backplane's side B slot spacing is designed to accommodate the added physical width common with many high-performance x16 video, graphics and GPU cards. The ability of Trenton PICMG 1.3 SHBs and the backplane to automatically support either PCI Express 3.0, 2.0 or 1.1 cards builds an element of scalability into any COTS system design. The backplane's small butterfly form factor lends itself well to 2U rackmount video display wall controllers, military/aerospace, medical diagnostics, and communication system designs. The BPC8219's expanded I/O capability, that enables support for up to four USB interfaces and a 10/100/1000Base-T Ethernet connection directly on the backplane, opens up numerous 2U rackmount computer system configuration options while delivering increased application flexibility and performance.

BACKPLANE MODEL: BPC8219

| MODEL# | MODEL NAME | DESCRIPTION |
|----------|-------------|--|
| 8219-013 | BPC8219-VER | One ATX/EPS and one 12V AUX vertical power connector plus support for one Ethernet and four USB backplane interfaces |

BPC8219 LAYOUT & MOUNTING HOLE PATTERN DIMENSIONS:

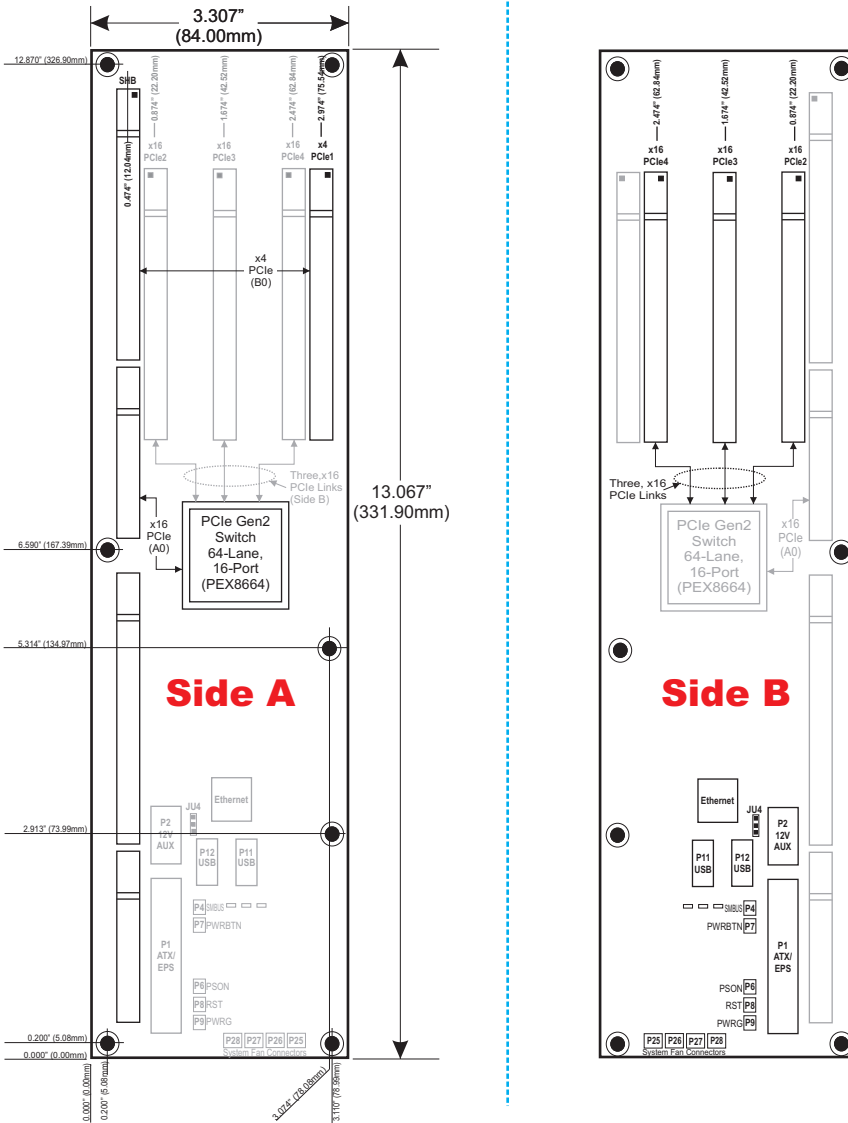

SUGGESTED TRENTON PICMG 1.3 SYSTEM HOST BOARDS: DUAL PROCESSOR SYSTEM HOST BOARD: BXT7059

SINGLE PROCESSOR SYSTEM HOST BOARD: TSB7053

ENVIRONMENTAL SPECIFICATIONS:#

Operating Temp.: 0° C to 60° C

Storage Temp.: -40° C to 70° C

Humidity: 5% to 90%, non-condensing

#Environmental specifications for system host boards / single board computers are usually lower than those of the backplane. Check with your SHB/SBC vendor.

The Trenton BPC8219 is a lead-free, RoHS compliant backplane.

This backplane is designed to meet worldwide EMI emissions requirements, CE conformity and immunity standards. Contact Trenton for the specific standard numbers this product.

The Trenton BPC8219 backplane is designed for UL60950 and CAN/CSA C22.2 No. 60950-00.

ENGINEERING NOTES:

1. The power connectors are shown in the layout drawing represents backplane model number 8219-013.
2. Mounting holes: 0.156" diameter
3. Nominal PCB thickness: 0.080"
4. All dimensions are inches.
5. ** (from page one) The optional USB, SATA and Ethernet connectivity is provided by the Trenton PICMG 1.3 System Host Boards. Not all SHBs support these capabilities.
6. Page one PCIe electrical interface key for the option card slots:
Green = Slot driven with a x16 PCIe 2.0 link
Black = Slot driven with a x4 PCIe 2.0 link/card slot

PCI EXPRESS 2.0 LINK STATUS LEDs:

The BPC8219 provides multiple PCI Express link status LEDs to provide a visual check on the operational speed of the backplane's x16 PCI Express links. The links monitored by the LEDs include A0 from the SHB to the 16-port/64-lane PCI Express Gen2 and the links routed to x16 card slots PCIe2, PCIe3 and PCIe4. The possible status states of the multi-purpose LEDs are illustrated in the table below.

- PCI Express Link Status LEDs - LED7 through LED11 -

| State | LED Pattern |
|-----------------------------------|----------------------|
| Link is down | Off |
| Link is up at 5.0 GT/s (PCIe 2.0) | On |
| Link is up at 2.5 GT/s (PCIe 1.1) | 0.25s On / 0.25s Off |

BACKPLANE JUMPER SETTINGS:

The BPC8219 jumpers are for the most part used during the manufacturing and test of the backplane and have no operational value in most system applications. However, JU4 is the exception to this general rule. JU4 is a +5VAUX jumper that offers a way around the lack of a of the required +5VAUX voltage needed by the SHB in those system configurations using non-ATX/EPS power supplies. Here are the jumper default settings:

| Jumper | Function | Pins To Short |
|--------|---------------------|-----------------------------------|
| JU1 | SHB I2C Bus | Leave Open, Do No Populate Jumper |
| JU2 | PCIe Switch I2C Bus | Leave Open, Do No Populate Jumper |
| JU3 | Slot/Clock I2C Bus | Leave Open, Do No Populate Jumper |
| JU4 | +5VAUX Source | ATX/EPS supply, Jumper Pins 2-3 |

Product Photo Note: The photo of the BPC8219 backplane shown on page one is provided for illustrative purposes only. Actual connector and mounting locations are illustrated in the backplane layout drawing.

PICMG is a registered trademark of the PCI Industrial Computer Manufacturers Group. All other product names are trademarks of their respective owners.

Copyright ©2014 by TRENTON Systems Inc. All rights reserved

**TRENTON
SYSTEMS®**
Engineered For Reliability

