

RL-5530

FLYBACK TRANSFORMER

FOR NATIONAL SEMICONDUCTOR

DESCRIPTION

- Flyback Transformer
- LM-258X-T1

ENVIRONMENTAL DATA

- Storage temperature range: -55°C to +130°C
- Operating temperature range: -40°C to +130°C

PACKAGING INFORMATION

- Packaging information: pg. 495

FEATURES & APPLICATIONS

- Compact through-hole transformer
- Flyback topology power supplies

Verify operation with sample in actual circuit. Order samples at www.rencousa.com.

MECHANICAL DIMENSIONS

U.S. Standard (mm)

PART NUMBER	A (MAX.)	B	C (MAX.)	D (MAX.)	E (MIN.)	F (TYP.)	G
RL-5530	0.93 (23.62)	0.515 (13.08)	0.78 (19.81)	0.70 (17.78)	0.125 (3.17)	0.20 (5.08)	0.15 (3.81)

PART NUMBER	PART WEIGHT
RL-5530	10.0g (0.35oz)

TEST MEASUREMENTS:

1. L (1-4) = 22.0 μ H \pm 10% AT 0.1 VRMS 10 kHz
2. RDC (1-4) = 0.022 Ω \pm 15% AT 25°
3. HIPOT: 600 VRMS BETWEEN (1-2) AND ALL OTHER WINDINGS

FRONT VIEW

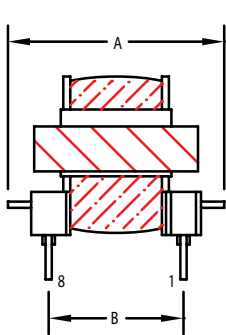

SIDE VIEW

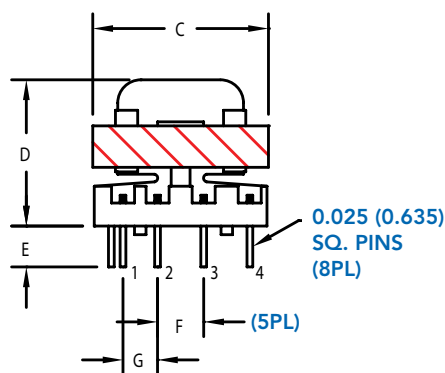

SCHEMATIC

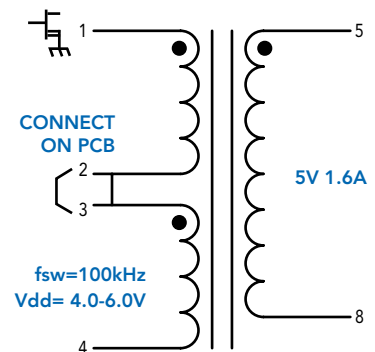

REFERENCE DESIGNS



RENCO ELECTRONICS INC.

595 International Place, Rockledge, FL 32955-4200 USA • www.rencousa.com • ISO 9001 Certified
Toll Free Engineering Hot Line: 800.645.5828 • P: 321.637.1000 • F: 321.637.1600

