

Data sheet

Carbon composition film preset potentiometers

Ordering code no.: 00 215



Series 215
Type PCH 215 / 10

Basic design: laminate base, plastic encased, double metal wiper

Special versions:

- Snap-in soldering terminals
- Centre notch detent

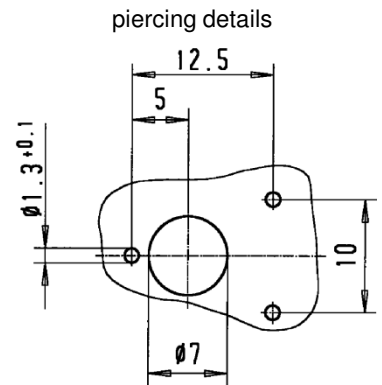
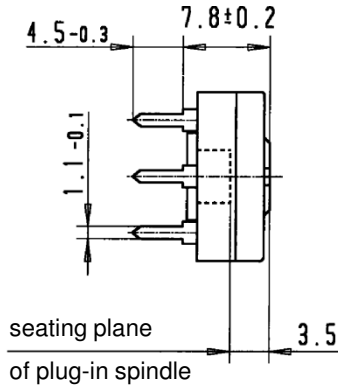
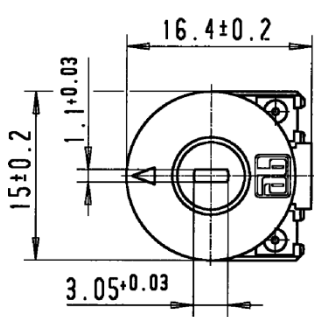

Technical data

Rated resistance range	100 Ω – 4.7 MΩ	Temperature coefficient	± 1 000 ppm / °C *
Resistance tolerance	± 20 % *	Electrical travel	240° ± 10° *
Law (resistance taper)	lin *	Mechanical travel	270° ± 10°
Independent linearity	± 10 % *	Operating torque	0.5 – 2.5 Ncm
Rated dissipation	0.15 W / 40 °C	End stop torque	≥ 10 Ncm
Limiting element voltage	250 V	Durability	100 cycles
Temperature range	-25 °C to + 70 °C		

Plastic moulded spindles

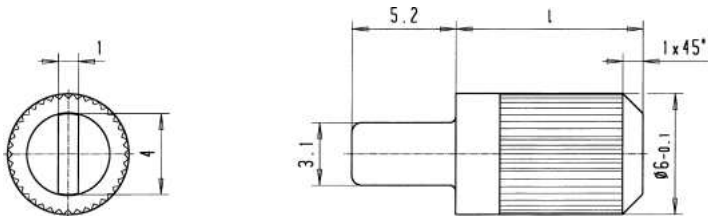

l = 9.3 mm ordering code no.: 20 103
l = 12.5 mm ordering code no.: 20 115

Colour: black

* other values on request

Technical details subject to change

This catalogue gives no information on product availability. The information is only for product description and is not legally binding. Any technical item is subject to change.