

SYSTIUM® MODEL 526 uATX CONVERTIBLE MICRO-TOWER/DESKTOP



The Systium® Model 526 is a small form factor uATX compliant convertible Micro-Tower/Desktop. The unique, long life design allows for the operation of the system in a vertical or horizontal configuration. The 526's unique form factor, convertibility and hidden CDROM makes this product a perfect choice for OEM applications without that "PC" look. CSA-UL, FCC-CE Certifications make this your perfect choice. Available with or without certifications.

- **Motherboards:** ITX, uATX
- **Power Supply:** 350W PSU- PFC, Auto-ranging
- **Drives: External** 1- 5.25", 1- 3.5"
- **Drives: Internal** 1- 3.5" Drive Bay (2nd w/ bracket option)
- **Add in Cards:** 4- Expansion Slots, Full height Full Length
- **Cooling:** 2- Rear 60mm Fans
- **Front Panel:** Power switch , 2 USB ports
- **Front Panel Indicators:** Power, HDD status LEDs
- **Unit Dimensions:**

	<u>H</u>	<u>W</u>	<u>D</u>
Weight	13"	5.4"	15.5"
	(329mm)	(136mm)	(394mm)
w/packaging	18.25"	9.75"	19.25"
	(463mm)	(247mm)	(489mm)

Finish

Black
52603-00R

Cool Gray
52604-00R

Options:

Fan filter, extra USB ports

Wall Mount Kit



Spare Drive Bracket



- **Certification** FCC Class B, CSA and CE approvals are available when the unit is integrated according to the Model 526 Assembly Guide included with the product. 526xx-xxR
- **Approved Motherboards:** BCM®, ITOX®, Intel®, RadiSys®
For a complete list of system engineered and agency approved motherboards please visit our website.

SYSTIUM® Technologies
MotherBoard Ready™ Solutions

4301 QUEBEC AVENUE NORTH, UNIT 1, NEW HOPE, MN 55428

Please contact your local Systium
Distributor for more information.

See www.systium.com

(763) 537-3600

Fax (763) 537-3625

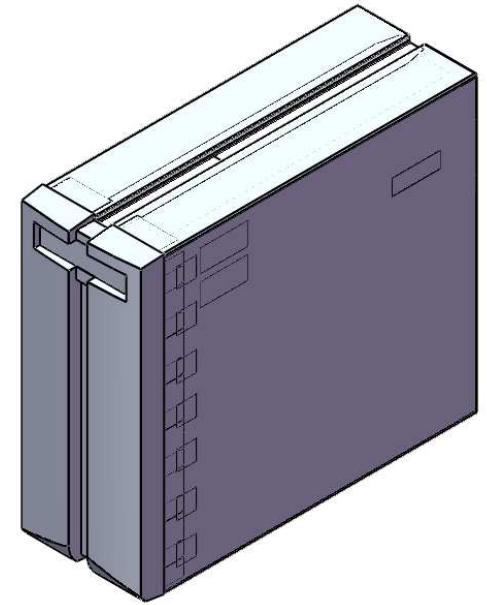
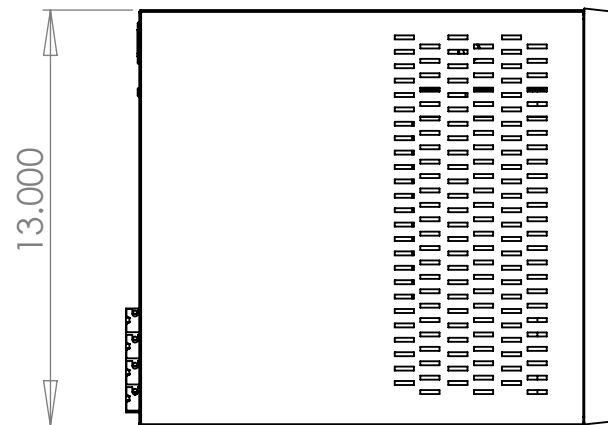
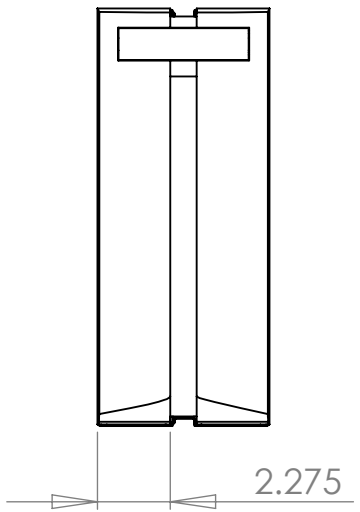
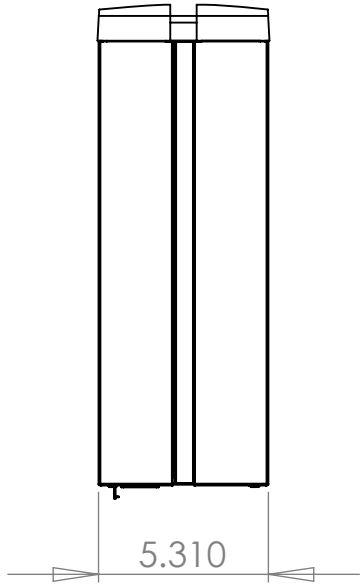

	NAME	DATE	Systemium Technologies, LLC	
DRAWN	DSC	11/24/2009	TITLE:	
PROPRIETARY AND CONFIDENTIAL THE INFORMATION CONTAINED IN THIS DRAWING IS THE SOLE PROPERTY OF Systemium Technologies, LLC. ANY REPRODUCTION IN PART OR AS A WHOLE WITHOUT THE WRITTEN PERMISSION OF Systemium Technologies, LLC. IS PROHIBITED. COPYRIGHT SYSTEMIUM TECHNOLOGIES, LLC			MODEL 526	
SIZE	DWG. NO.	REV		
A	526			
SCALE: 1:6	WEIGHT:	SHEET 1 OF 1		