

GT7121



10MHz, Low Power, CMOS, Rail-to-Rail Operational Amplifier

Advanced

1. Features

- Single-Supply Operation from +2.2V ~ +5.5V
- Rail-to-Rail Input / Output
- Gain-Bandwidth Product: 10MHz (Typ.)
- Low Input Bias Current: 10pA (Typ.)
- Low Offset Voltage: 5mV (Max.)
- Quiescent Current: 800 μ A per Amplifier (Typ.)
- Operating Temperature: -40°C ~ +125°C
- Available in SOT23-5 and SOP8 Packages

2. General Description

The GT7121 is wideband, low-noise, low-distortion dual operational amplifier, that offer rail-to-rail inputs/outputs and single-supply operation down to 2.2V. They draw 1.6mA of quiescent supply current while featuring ultra-low distortion (0.0002% THD+N), as well as low input voltage-noise density (15nV/ \sqrt Hz) and low input current-noise density (0.5fA/ \sqrt Hz). These features make the devices an ideal choice for applications that require low distortion and/or low noise.

These amplifiers have inputs and outputs which swing rail-to-rail and their input common-mode voltage range includes ground. The maximum input offset of these amplifiers is less than 5mV. The GT7121 are unity-gain stable with a gain-bandwidth product of 10MHz. The GT7121 is available in SOT23-5 and SOP8 packages. The extended temperature range of -40°C to +125°C over all supply voltages offers additional design flexibility.

3. Applications

- Portable Equipment
- Mobile Communications
- Smoke Detector
- Sensor Interface
- Medical Instrumentation
- Battery-Powered Instruments
- Handheld Test Equipment

4. Pin Configuration

4.1 GT7121 SOP23-5 and SOP8 (Top View)

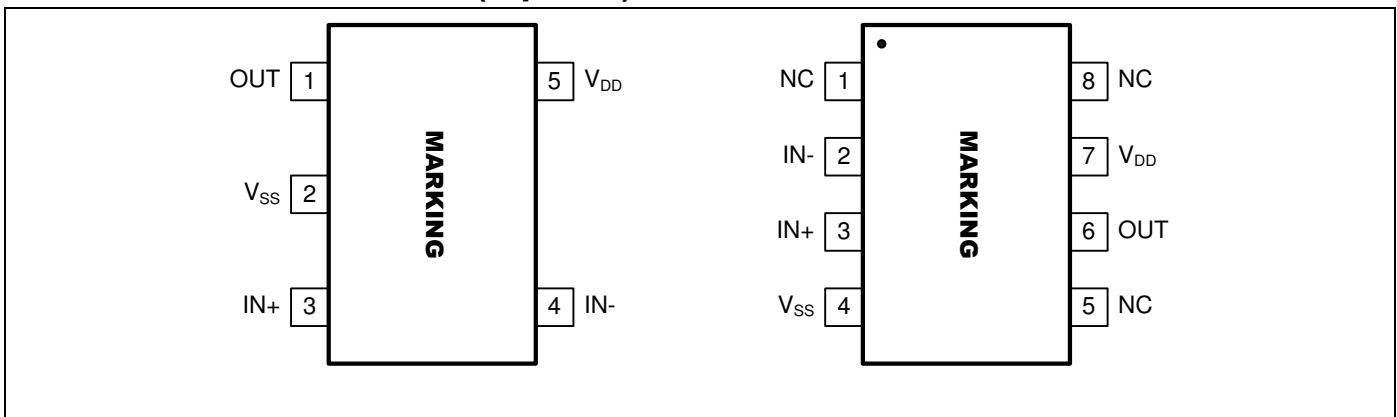

Copyright © 2010 Giantec Semiconductor Inc. (Giantec). All rights reserved. Giantec reserves the right to make changes to this specification and its products at any time without notice. Giantec products are not designed, intended, authorized or warranted for use as components in systems or equipment intended for critical medical or surgical equipment, aerospace or military, or other applications planned to support or sustain life. It is the customer's obligation to optimize the design in their own products for the best performance and optimization on the functionality and etc. Giantec assumes no liability arising out of the application or use of any information, products or services described herein. Customers are advised to obtain the latest version of this device specification before relying on any published information and prior placing orders for products.



GT7121

Figure 1. Pin Assignment Diagram (SOP23-5 and SOP8 Package)

Note: Please see section “**Part Markings**” for detailed Marking Information.



GT7121

5. Application Information

5.1 Size

GT7121 series op amps are unity-gain stable and suitable for a wide range of general-purpose applications. The small footprints of the GT7121 series packages save space on printed circuit boards and enable the design of smaller electronic products.

5.2 Power Supply Bypassing and Board Layout

GT7121 series operates from a single 2.2V to 5.5V supply or dual $\pm 1.1V$ to $\pm 2.75V$ supplies. For best performance, a $0.1\mu F$ ceramic capacitor should be placed close to the V_{DD} pin in single supply operation. For dual supply operation, both V_{DD} and V_{SS} supplies should be bypassed to ground with separate $0.1\mu F$ ceramic capacitors.

5.3 Low Supply Current

The low supply current (typical $400\mu A$) of GT7121 series will help to maximize battery life. They are ideal for battery powered systems

5.4 Operating Voltage

GT7121 series operate under wide input supply voltage (2.2V to 5.5V). In addition, all temperature specifications apply from $-40^{\circ}C$ to $+125^{\circ}C$. Most behavior remains unchanged throughout the full operating voltage range. These guarantees ensure operation throughout the single Li-Ion battery lifetime

5.5 Rail-to-Rail Input

The input common-mode range of GT7121 series extends $100mV$ beyond the supply rails ($V_{SS}-0.1V$ to $V_{DD}+0.1V$). This is achieved by using complementary input stage. For normal operation, inputs should be limited to this range.

5.6 Rail-to-Rail Output

Rail-to-Rail output swing provides maximum possible dynamic range at the output. This is particularly important when operating in low supply voltages. The output voltage of GT7121 series can typically swing to less than $10mV$ from supply rail in light resistive loads ($>100k\Omega$), and $60mV$ of supply rail in moderate resistive loads ($10k\Omega$).

5.7 Capacitive Load Tolerance

The GT7121 series can directly drive $250pF$ capacitive load in unity-gain without oscillation. Increasing the gain enhances the amplifier's ability to drive greater capacitive loads. In unity-gain configurations, the capacitive load drive can be improved by inserting an isolation resistor R_{ISO} in series with the capacitive load, as shown in **Figure 2**.

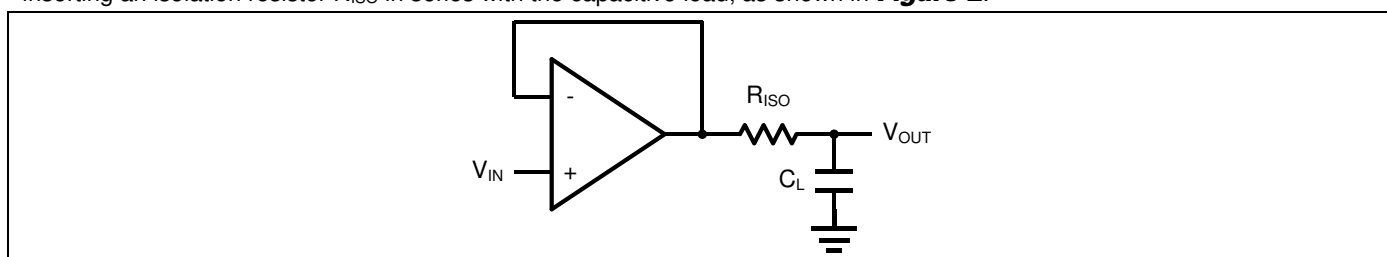

Figure 2. Indirectly Driving a Capacitive Load Using Isolation Resistor

The bigger the R_{ISO} resistor value, the more stable V_{OUT} will be. However, if there is a resistive load R_L in parallel with the capacitive load, a voltage divider (proportional to R_{ISO}/R_L) is formed, this will result in a gain error.

The circuit in **Figure 3** is an improvement to the one in **Figure 2**. R_F provides the DC accuracy by feed-forward the V_{IN} to R_L . C_F and R_{ISO} serve to counteract the loss of phase margin by feeding the high frequency component of the output signal back to the amplifier's inverting input, thereby preserving the phase margin in the overall feedback loop. Capacitive drive can be increased

by increasing the value of C_F . This in turn will slow down the pulse response.

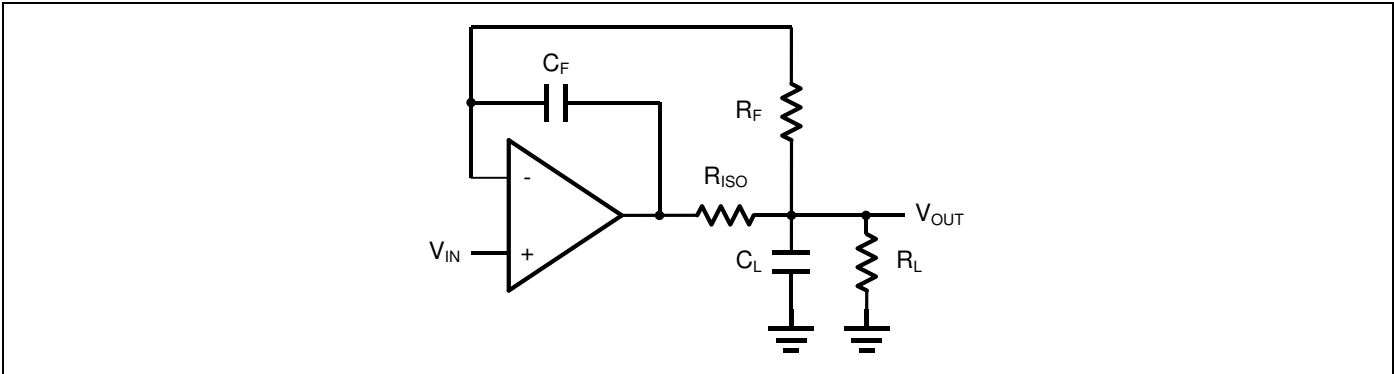

Figure 3. Indirectly Driving a Capacitive Load with DC Accuracy

5.8 Differential amplifier

The differential amplifier allows the subtraction of two input voltages or cancellation of a signal common to the two inputs. It is useful as a computational amplifier in making a differential to single-end conversion or in rejecting a common mode signal. **Figure 4.** shows the differential amplifier using GT7121.

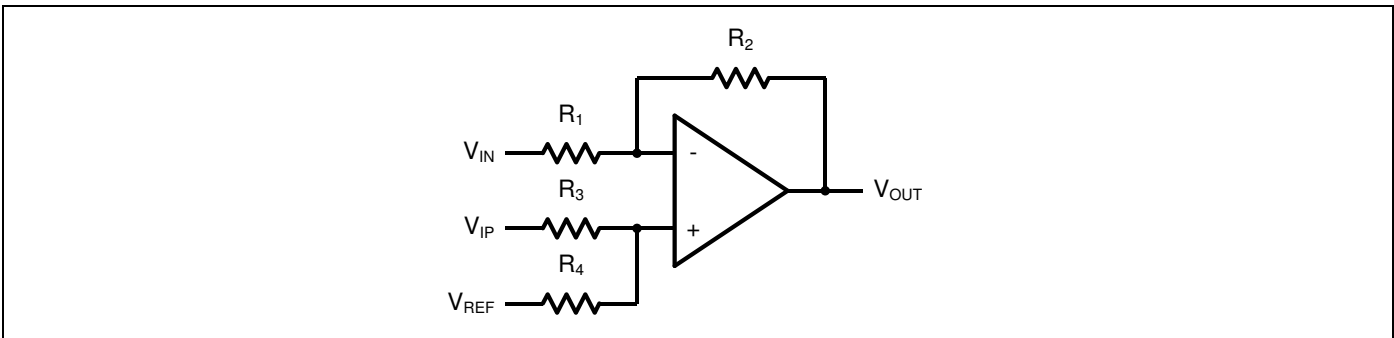

Figure 4. Differential Amplifier

$$V_{OUT} = \left(\frac{R_1+R_2}{R_3+R_4}\right) \frac{R_4}{R_1} V_{IN} - \frac{R_2}{R_1} V_{IP} + \left(\frac{R_1+R_2}{R_3+R_4}\right) \frac{R_3}{R_1} V_{REF}$$

If the resistor ratios are equal (i.e. $R_1=R_3$ and $R_2=R_4$), then

$$V_{OUT} = \frac{R_2}{R_1} (V_{IP} - V_{IN}) + V_{REF}$$

5.9 Instrumentation Amplifier

The input impedance of the previous differential amplifier is set by the resistors R_1 , R_2 , R_3 , and R_4 . To maintain the high input impedance, one can use a voltage follower in front of each input as shown in the following two instrumentation amplifiers.

5.10 Three-Op-Amp Instrumentation Amplifier

The dual GT7121 can be used to build a three-op-amp instrumentation amplifier as shown in **Figure 5.**



GT7121

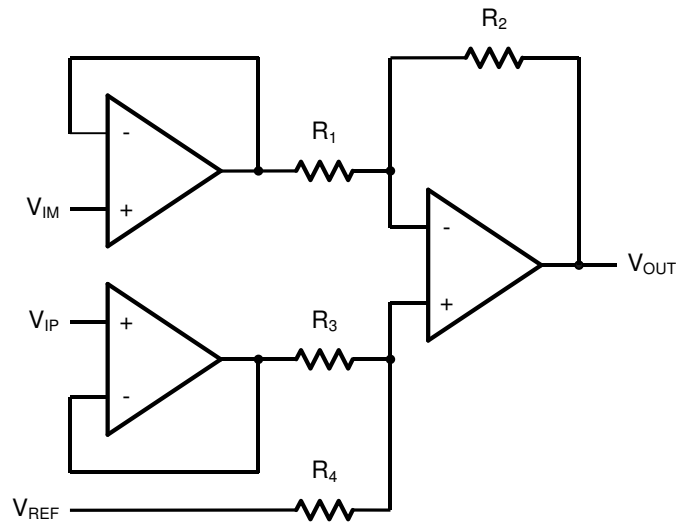

Figure 5. Three-Op-Amp Instrumentation Amplifier

The amplifier in **Figure 5** is a high input impedance differential amplifier with gain of R_2/R_1 . The two differential voltage followers assure the high input impedance of the amplifier.

$$V_o = \left(1 + \frac{R_4}{R_3}\right)(V_{IP} - V_{IN})$$

5.11 Two-Op-Amp Instrumentation Amplifier

GT7121 can also be used to make a high input impedance two-op-amp instrumentation amplifier as shown in **Figure 6**.

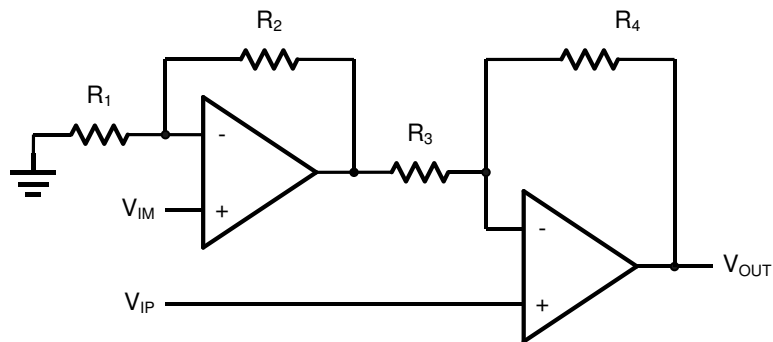

Figure 6. Two-Op-Amp Instrumentation Amplifier

Where $R_1=R_3$ and $R_2=R_4$. If all resistors are equal, then $V_o=2(V_{IP}-V_{IN})$

5.12 Single-Supply Inverting Amplifier

The inverting amplifier is shown in Figure 6. The capacitor C_1 is used to block the DC signal going into the AC signal source V_{IN} . The value of R_1 and C_1 set the cut-off frequency to $f_c=1/(2\pi R_1 C_1)$. The DC gain is defined by $V_{OUT}=-R_2/R_1 V_{IN}$

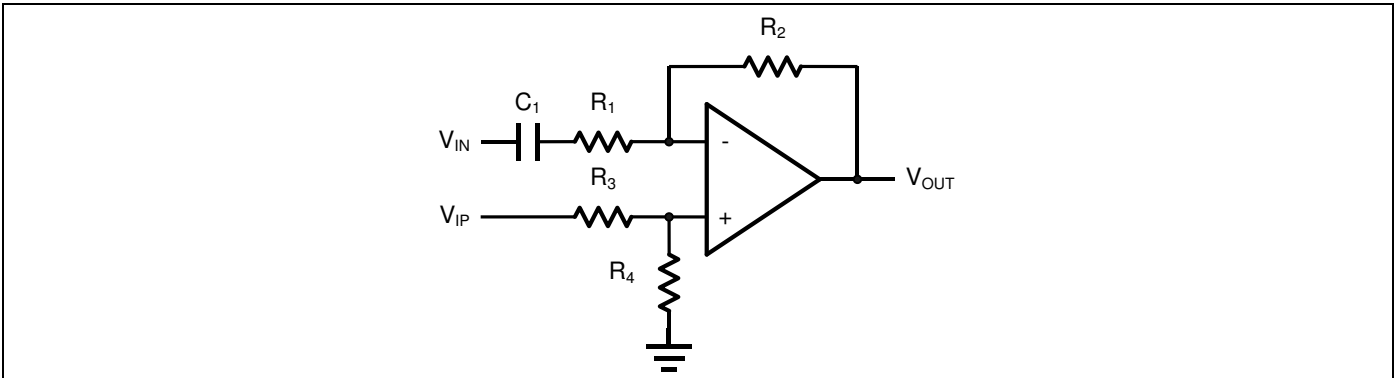

Figure 7. Single Supply Inverting Amplifier

5.13 Low Pass Active Filter

The low pass active filter is shown in **Figure 8**. The DC gain is defined by $-R_2/R_1$. The filter has a -20dB/decade roll-off after its corner frequency $f_c=1/(2\pi R_3 C_1)$.

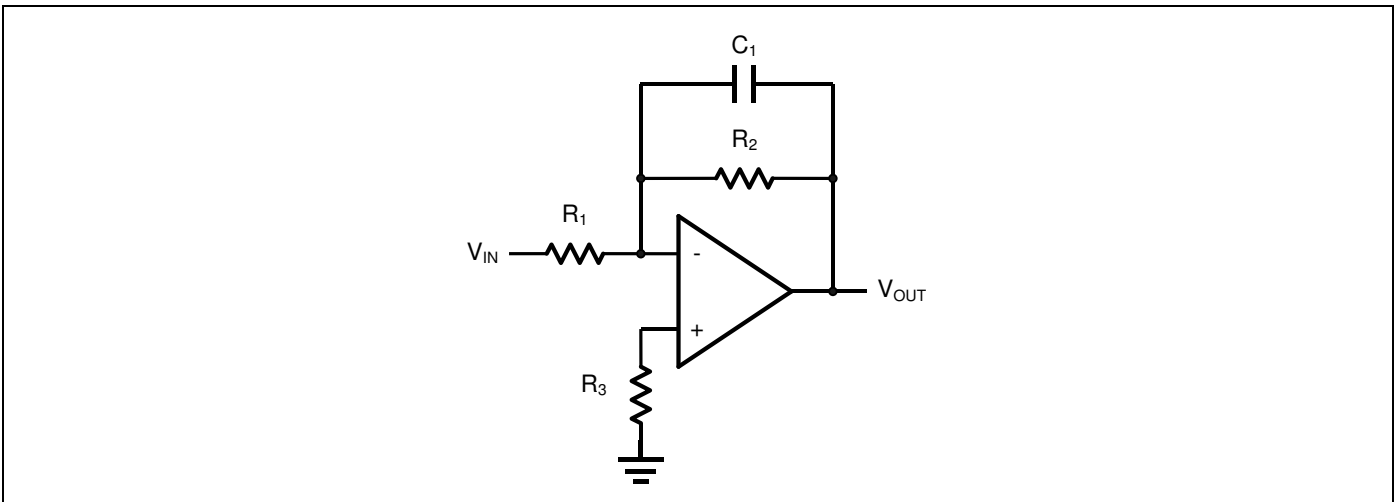

Figure 8. Low Pass Active Filter

5.14 Sallen-Key 2nd Order Active Low-Pass Filter

GT7121 can be used to form a 2nd order Sallen-Key active low-pass filter as shown in **Figure 9**. The transfer function from V_{IN} to V_{OUT} is given by

$$\frac{V_{OUT}}{V_{IN}}(S) = \frac{\frac{1}{C_1 C_2 R_1 R_2} A_{LP}}{S^2 + S \left(\frac{1}{C_1 R_1} + \frac{1}{C_1 R_2} + \frac{1}{C_2 R_2} - \frac{A_{LP}}{C_2 R_2} \right) + \frac{1}{C_1 C_2 R_1 R_2}}$$

Where the DC gain is defined by $A_{LP}=1+R_3/R_4$, and the corner frequency is given by

$$\omega_c = \sqrt{\frac{1}{C_1 C_2 R_1 R_2}}$$

The pole quality factor is given by



GT7121

$$\frac{\omega C}{Q} = \frac{1}{C_1 R_1} + \frac{1}{C_1 R_2} + \frac{1}{C_2 R_2} - \frac{A_{LP}}{C_2 R_2}$$

Let $R_1=R_2=R$ and $C_1=C_2=C$, the corner frequency and the pole quality factor can be simplified as below

$$\omega_C = \frac{1}{CR}$$

And $Q=2-R_3/R_4$

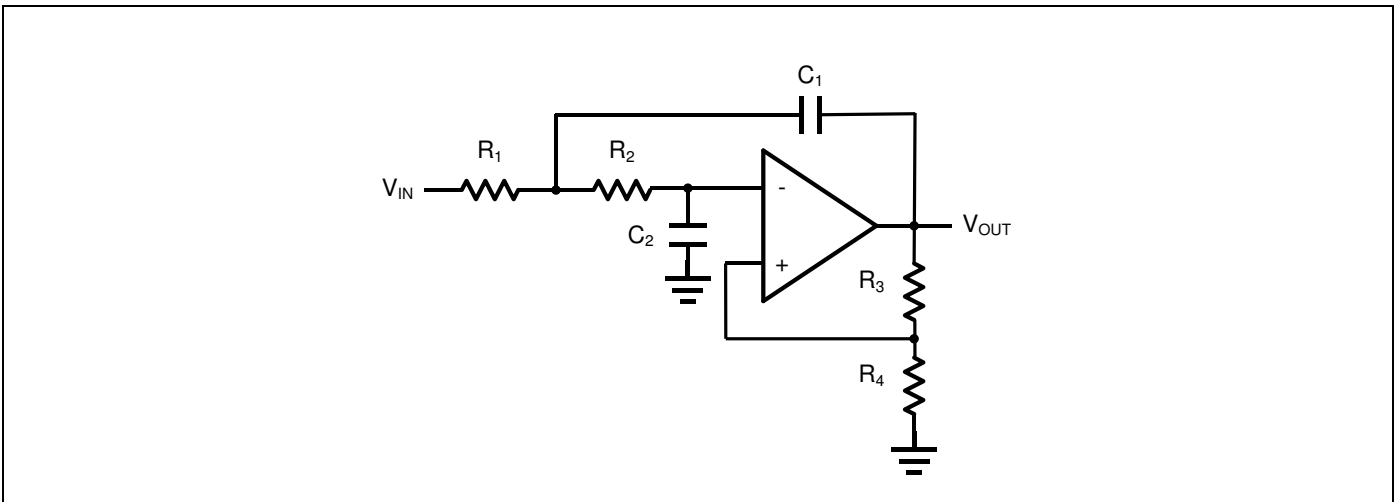

Figure 9. Sallen-Key 2nd Order Active Low-Pass Filter

5.15 Sallen-Key 2nd Order high-Pass Active Filter

The 2nd order Sallen-key high-pass filter can be built by simply interchanging those frequency selective components R_1 , R_2 , C_1 , and C_2 as shown in **Figure 10**.

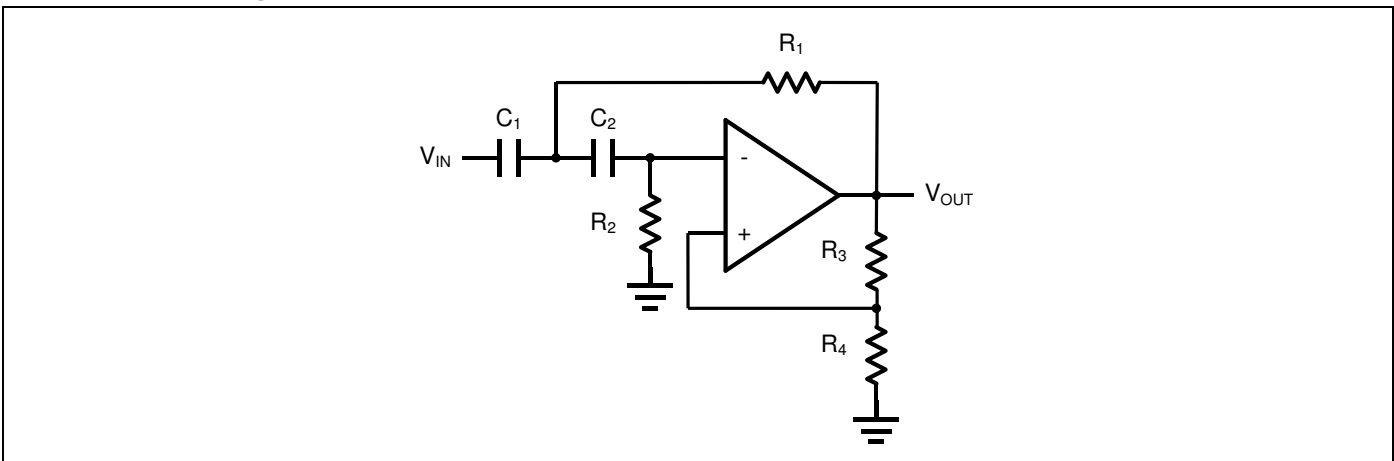

Figure 10. Sallen-Key 2nd Order Active High-Pass Filter

$$\frac{V_{OUT}}{V_{IN}}(S) = \frac{S^2 A_{HP}}{S^2 + S\left(\frac{1}{C_1 R_1} + \frac{1}{C_2 R_2} + \frac{1-A_{HP}}{C_1 R_1}\right) + \frac{1}{C_1 C_2 R_1 R_2}}$$

Where $A_{HP}=1+R_3/R_4$



GT7121

6. Electrical Characteristics

6.1 Absolute Maximum Ratings

Condition	Min	Max
Power Supply Voltage (V_{DD} to V_{SS})	-0.5V	+7V
Analog Input Voltage ($IN+$ or $IN-$)	$V_{SS}-0.5V$	$V_{DD}+0.5V$
PDB Input Voltage	$V_{SS}-0.5V$	+7V
Operating Temperature Range	-40 °C	+125 °C
Junction Temperature	+150 °C	
Storage Temperature Range	-65 °C	+150 °C
Lead Temperature (soldering, 10sec)	+300 °C	
Package Thermal Resistance ($T_A=+25^{\circ}C$)		
SOP8, θ_{JA}	130 °C	
MSOP8, θ_{JA}	210 °C	

Note: Stress greater than those listed under Absolute Maximum Ratings may cause permanent damage to the device. This is a stress rating only and functional operation of the device at these or any other conditions outside those indicated in the operational sections of this specification are not implied. Exposure to absolute maximum rating conditions for extended periods may affect reliability.



GT7121

6.2 Electrical Characteristics

($V_{DD} = +5V$, $V_{SS} = 0V$, $V_{CM} = 0V$, $V_{OUT} = V_{DD}/2$, $R_L = 100K$ tied to $V_{DD}/2$, $SHDNB = V_{DD}$, $T_A = -40^\circ C$ to $+125^\circ C$, unless otherwise noted. Typical values are at $T_A = +25^\circ C$.) (Notes 1)

Parameter	Symbol	Conditions	Min.	Typ.	Max.	Units
Supply-Voltage Range	V_{DD}	Guaranteed by the PSRR test	2.2	-	5.5	V
Quiescent Supply Current (per Amplifier)	I_{DD}	$V_{DD} = 3V$	-	0.8	-	mA
		$V_{DD} = 5V$	-	0.8	1.2	
Input Offset Voltage	V_{OS}	$T_A = +25^\circ C$	-	-	± 5	mV
		$T_A = -40^\circ C$ to $+85^\circ C$	-	-	-	
		$T_A = -40^\circ C$ to $+125^\circ C$	-	-	± 1.5	
Input Offset Voltage Tempco	$\Delta V_{OS}/\Delta T$		-	± 0.3	± 6	$\mu V/^\circ C$
Input Bias Current	I_B	(Note 3)	-	± 1	± 100	pA
Input Offset Current	I_{OS}	(Note 3)	-	± 1	± 100	pA
Input Common-Mode Voltage Range	V_{CM}	Guaranteed by the $T_A = 25^\circ C$	-0.2	-	$V_{DD} + 0.2$	V
		CMRR test $T_A = -40^\circ C$ to $+125^\circ C$	0	-	$V_{DD} 0$	
Common-Mode Rejection Ratio	CMRR	$V_{SS} - 0.2V \leq V_{CM} \leq V_{DD} + 0.2V$ $T_A = +25^\circ C$	-	75	-	dB
		$V_{SS} \leq V_{CM} \leq 5V$ $T_A = +25^\circ C$	65	80	-	
		$V_{SS} - 0.2V \leq V_{CM} \leq V_{DD} + 0.2V$ $T_A = -40^\circ C$ to $+125^\circ C$	-	65	-	
Power-Supply Rejection Ratio	PSRR	$V_{DD} = +2.2V$ to $+5.5V$	75	90	-	dB
Open-Loop Voltage Gain	A_V	$R_L = 100k\Omega$ to $V_{DD}/2$, $100mV \leq V_O \leq V_{DD} - 125mV$	90	100	-	dB
		$R_L = 1k\Omega$ to $V_{DD}/2$, $200mV \leq V_O \leq V_{DD} - 250mV$	75	85	-	
		$R_L = 500\Omega$ to $V_{DD}/2$, $350mV \leq V_O \leq V_{DD} - 500mV$	55	65	-	
Output Voltage Swing	V_{OUT}	$ V_{IN+} - V_{IN-} \geq 10mV$ $V_{DD} - V_{OH}$	-	10	35	mV
		$R_L = 10k\Omega$ to $V_{DD}/2$ $V_{OL} - V_{SS}$	-	10	30	
		$ V_{IN+} - V_{IN-} \geq 10mV$ $V_{DD} - V_{OH}$	-	80	200	
		$R_L = 1k\Omega$ to $V_{DD}/2$ $V_{OL} - V_{SS}$	-	50	150	
		$ V_{IN+} - V_{IN-} \geq 10mV$ $V_{DD} - V_{OH}$	-	100	350	



GT7121

		$R_L = 500\Omega$ to $V_{DD}/2$ $V_{OL}-V_{SS}$		80	260	
Output Short-Circuit Current	I_{SC}	Sinking or Sourcing	-	± 50	-	mA
PDB Logic Low	V_{IL}		-	-	0.8	V
PDB Logic High	V_{IH}		2	-	-	V
Turn-On Time	T_{ON}		-	2.2	-	μs
Turn-Off Time	T_{OFF}		-	0.8	-	μs
Output Leakage Current	I_{LEAK}	Shutdown Mode (PDB = V_{SS}), $V_{OUT} = V_{SS}$ to V_{DD}	-	± 0.001	± 1.0	μA
Input Capacitance	C_{IN}			10		pF
Gain Bandwidth Product	GBW	$A_V = +1V/V$	-	10	-	MHz
Slew Rate	SR	$A_V = +1V/V$	-	4.5	-	V/ μs
Full Power Bandwidth		$A_V = +1V/V$	-	0.4	-	MHz
Phase Margin	ϕ_m	$A_V = +1V/V$	-	55	-	deg
Gain Margin	G_m	$A_V = +1V/V$	-	12	-	dB
Settling Time	t_s	To 0.01%, $V_{OUT} = 2V$ step $A_V = +1V/V$	-	1	-	μs
Capacitive-Load Stability	C_{LOAD}	No sustained oscillations. $A_V = +1V/V$	-	200	-	pF
Peak-to-Peak Input Noise Voltage (Note 5)	$e_{n(p-p)}$	$f = 0.1Hz$ to 10Hz	-	5	-	μV_{p-p}
Input Voltage Noise Density	e_n	$f = 10Hz$	-	60	-	nV/ \sqrt{Hz}
		$f = 1kHz$	-	30	-	
		$f = 30kHz$	-	15	-	
Input Current Noise Density	i_n	$f = 1kHz$				fA/ \sqrt{Hz}
Total Harmonic Distortion plus Noise	THD+N	$V_{OUT} = 2V_{p-p}$, $A_V = +1V/V$, $f = 1kHz$	-	0.0001	-	%
		$R_L = 10k\Omega$ to GND $f = 20kHz$	-	0.002	-	
		$V_{OUT} = 2V_{p-p}$, $A_V = +1V/V$, $f = 1kHz$	-	0.0002	-	
		$R_L = 1k\Omega$ to GND $f = 20kHz$	-	0.004	-	

Note 1: All devices are 100% production tested at $T_A = +25^\circ C$; all specifications over the automotive temperature range is guaranteed by design, not production tested.

Note 2: Parameter is guaranteed by design.

Note 3: Peak-to-peak input noise voltage is defined as six times RMS value of input noise voltage.



GT7121

7. Ordering Information

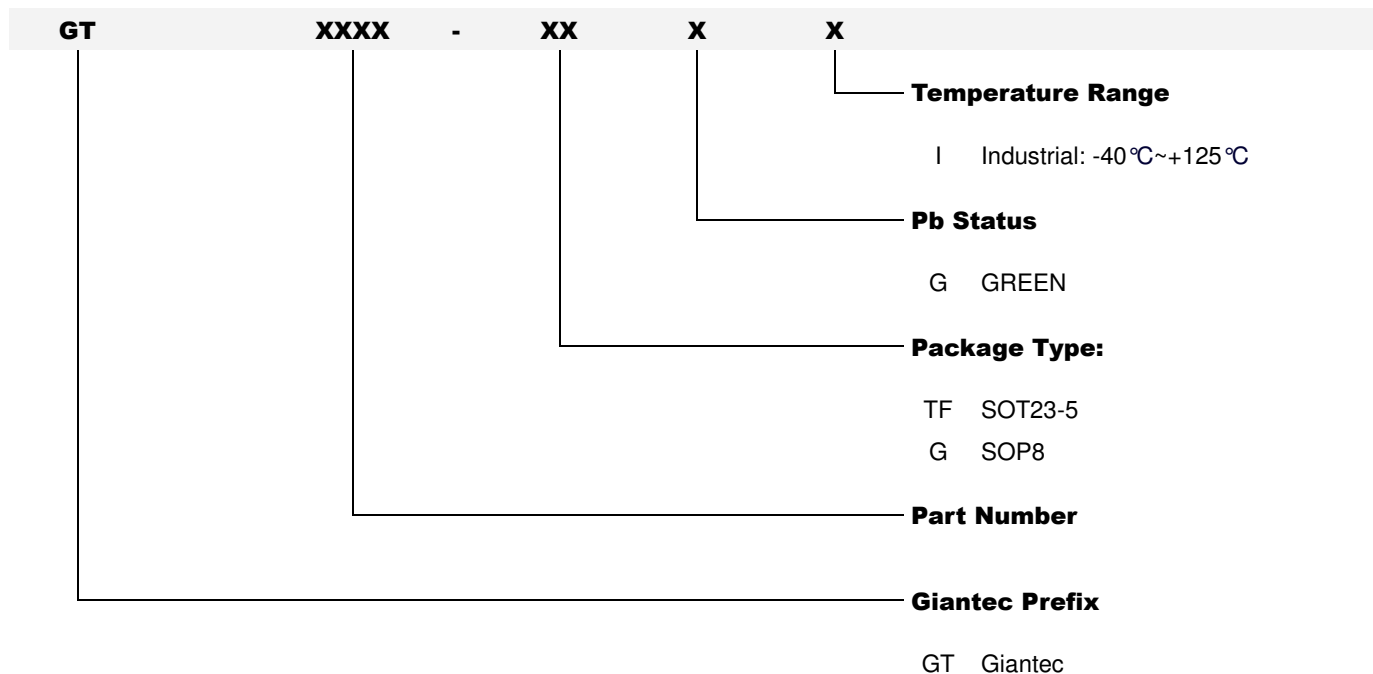

Order Number	Package Description	Package Option
GT7121-TFGI-TR	SOT23-5	Tape and Reel 3000
GT7121-GGI-TR	SOP8	Tape and Reel 4000



GT7121

8. Part Markings

8.1 GT7121-TFGI (Top View)



121	GT7121-TFGI			
●	Pin 1 Indicator			
Y	Seal Year	W		Seal Week
2010 (1st half year)	A	Week 01		A
2010 (2nd half year)	B	Week 02		B
2011 (1st half year)	C		
2011 (2nd half year)	D	Week 26		Z
2012 (1st half year)	E	Week 27		A
2012 (2nd half year)	F	Week 28		B
.....
2022 (2nd half year)	Z	Week 52		Z



GT7121

8.2 GT7121-GGI (Top View)

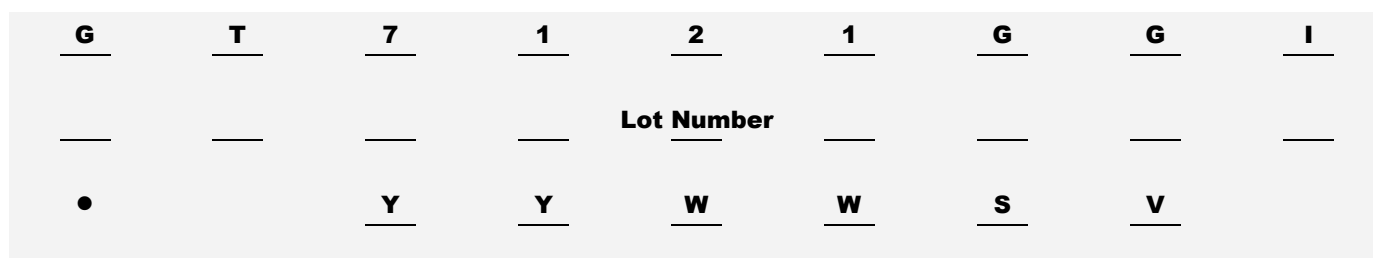

GT7121GGI

Lot Number States the last 9 characters of the wafer lot information

• Pin 1 Indicator

YY Seal Year

00 = 2000

01 = 2001

99 = 2099

WW Seal Week

01 = Week 1

02 = Week 2

.

.

.

51 = Week 51

52 = Week 52

S Subcon Code

J = ASESH

L = ASEKS

V Die Version



GT7121

9. Package Information

9.1 SOP8

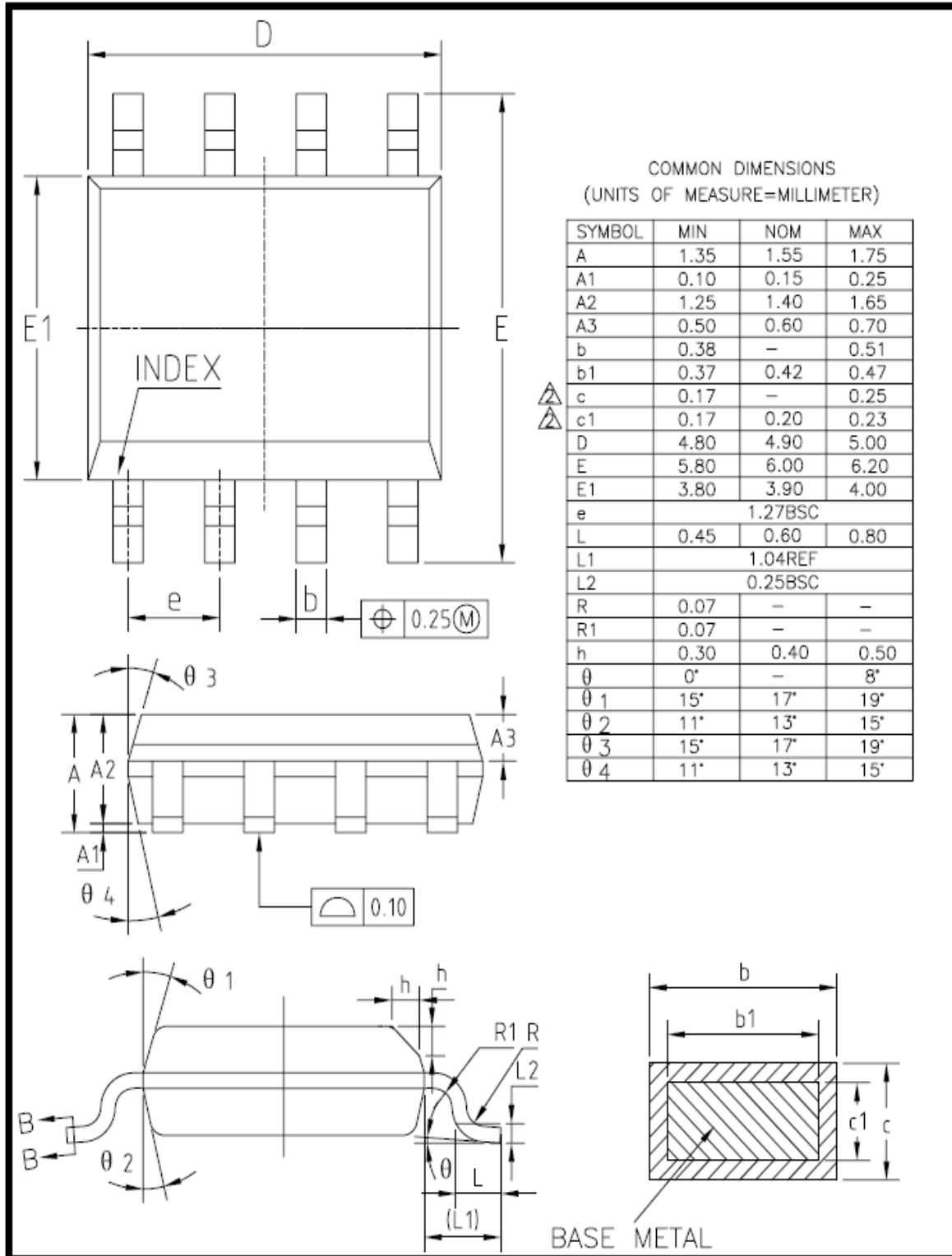



GT7121

9.2 MSOP8

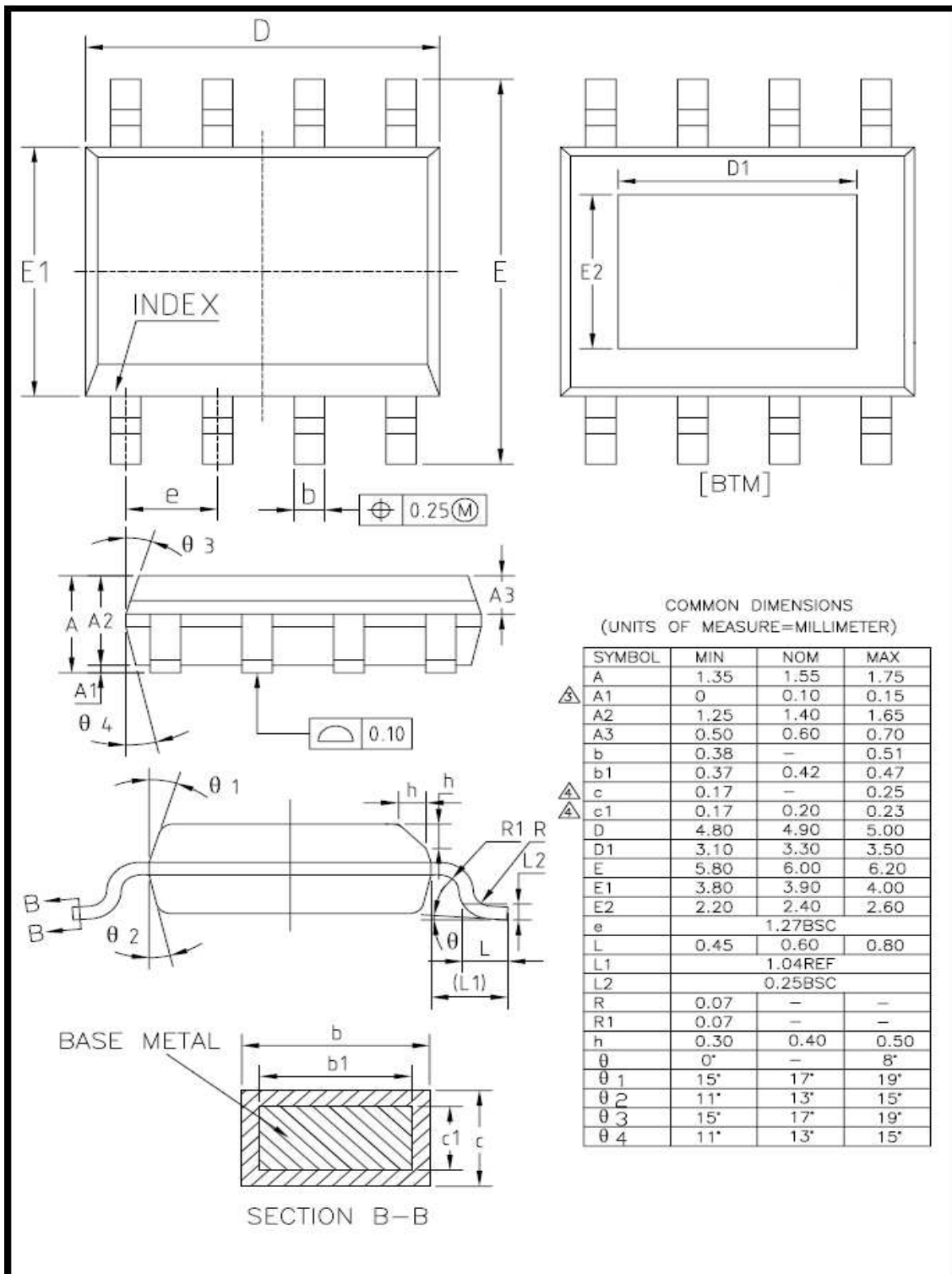



GT7121

10. Revision History

Revision	Date	Descriptions
A0	Oct.,2011	Initial Version