

GT7111



200MHz, High Speed, CMOS, Rail-to-Rail Operational Amplifier

Advanced

1. Features

- Single-Supply Operation from +2.5V ~ +5.5V
- Rail-to-Rail Input / Output
- Gain-Bandwidth Product: 200MHz (Typ.)
- Low Input Bias Current: 10pA (Typ.)
- Low Offset Voltage: 5mV (Max.)
- Quiescent Current: 2.8mA (Typ.)
- Operating Temperature: -40°C ~ +125°C
- Available in SOT23-5 and SOP8 Packages

2. General Description

The GT7111 is wideband, low-noise, low-distortion operational amplifier, that offer rail-to-rail output and single-supply operation down to 2.5V. They draw 2.8mA of quiescent supply current, as well as low input voltage-noise density (13nV/ $\sqrt{\text{Hz}}$) and low input current-noise density (400fA/ $\sqrt{\text{Hz}}$). These features make the devices an ideal choice for applications that require low distortion and low noise. The GT7111 has output which swing rail-to-rail and their input common-mode voltage range includes ground and offer wide bandwidth to 200MHz (G=+1). They are specified over the extended industrial temperature range (-45°C ~ 125°C). The single GT7111 is available in space-saving, SOT23-5 and SOP-8 packages.

3. Applications

- Portable Equipment
- Mobile Communications
- Smoke Detector
- Sensor Interface
- Medical Instrumentation
- Handheld Test Equipment
- Imaging/video

4. Pin Configuration

4.1 GT7111 SOT23-5 and SOP8 (Top View)

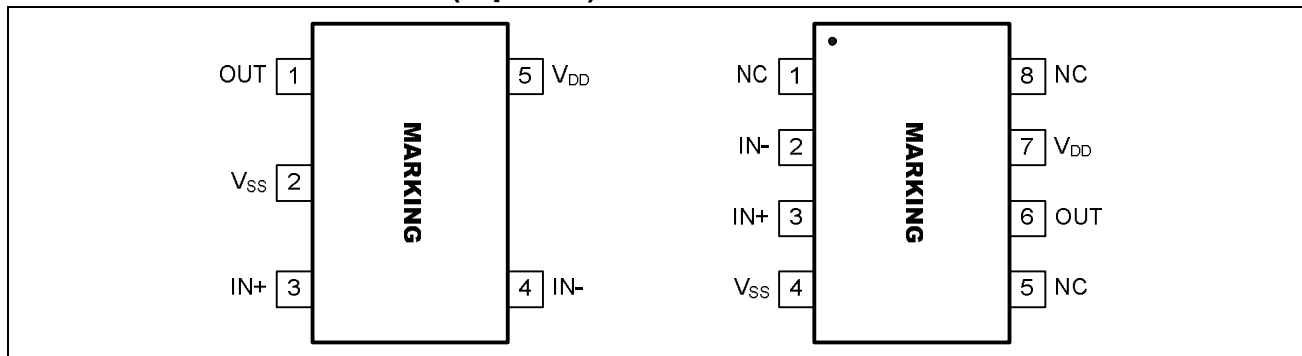

Figure 1. Pin Assignment Diagram (SOP23-5 and SOP8 Package)

Note: Please see section “Part Markings” for detailed Marking Information.

Copyright © 2010 Giantec Semiconductor Inc. (Giantec). All rights reserved. Giantec reserves the right to make changes to this specification and its products at any time without notice. Giantec products are not designed, intended, authorized or warranted for use as components in systems or equipment intended for critical medical or surgical equipment, aerospace or military, or other applications planned to support or sustain life. It is the customer's obligation to optimize the design in their own products for the best performance and optimization on the functionality and etc. Giantec assumes no liability arising out of the application or use of any information, products or services described herein. Customers are advised to obtain the latest version of this device specification before relying on any published information and prior placing orders for products.

5. Application Information

5.1 Size

GT7111 series op amps are unity-gain stable and suitable for a wide range of general-purpose applications. The small footprints of the GT7111 series packages save space on printed circuit boards and enable the design of smaller electronic products.

5.2 Power Supply Bypassing and Board Layout

GT7111 series operates from a single 2.5V to 5.5V supply or dual $\pm 1.25\text{V}$ to $\pm 2.75\text{V}$ supplies. For best performance, a $0.1\mu\text{F}$ ceramic capacitor should be placed close to the V_{DD} pin in single supply operation. For dual supply operation, both V_{DD} and V_{SS} supplies should be bypassed to ground with separate $0.1\mu\text{F}$ ceramic capacitors.

5.3 Low Supply Current

The low supply current (typical 2.8mA) of GT7111 series will help to maximize battery life. They are ideal for battery powered systems

5.4 Operating Voltage

GT7111 series operate under wide input supply voltage (2.2V to 5.5V). In addition, all temperature specifications apply from -40°C to $+125^{\circ}\text{C}$. Most behavior remains unchanged throughout the full operating voltage range. These guarantees ensure operation throughout the single Li-Ion battery lifetime

5.5 Rail-to-Rail Input

The input common-mode range of GT7111 series extends 5mV beyond the supply rails ($V_{\text{SS}}-0.1\text{V}$ to $V_{\text{DD}}+0.1\text{V}$). This is achieved by using complementary input stage. For normal operation, inputs should be limited to this range.

5.6 Rail-to-Rail Output

Rail-to-Rail output swing provides maximum possible dynamic range at the output. This is particularly important when operating in low supply voltages. The output voltage of GT7111 series can typically swing to less than 10mV from supply rail in light resistive loads ($>100\text{k}\Omega$), and 60mV of supply rail in moderate resistive loads ($10\text{k}\Omega$).

5.7 Capacitive Load Tolerance

The GT7111 series can directly drive 250pF capacitive load in unity-gain without oscillation. Increasing the gain enhances the amplifier's ability to drive greater capacitive loads. In unity-gain configurations, the capacitive load drive can be improved by inserting an isolation resistor R_{ISO} in series with the capacitive load, as shown in **Figure 2**.

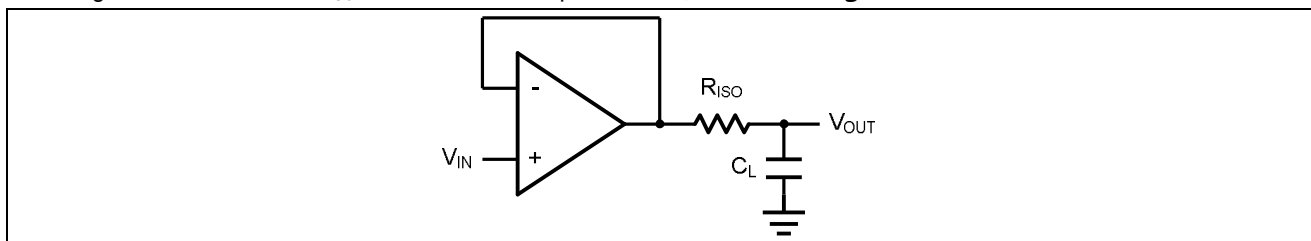

Figure 2. Indirectly Driving a Capacitive Load Using Isolation Resistor

The bigger the R_{ISO} resistor value, the more stable V_{OUT} will be. However, if there is a resistive load R_{L} in parallel with the capacitive load, a voltage divider (proportional to $R_{\text{ISO}}/R_{\text{L}}$) is formed, this will result in a gain error.

The circuit in **Figure 3** is an improvement to the one in **Figure 2**. R_{F} provides the DC accuracy by feed-forward the V_{IN} to R_{L} . C_{F} and R_{ISO} serve to counteract the loss of phase margin by feeding the high frequency component of the output signal back to the amplifier's inverting input, thereby preserving the phase margin in the overall feedback loop. Capacitive drive can be increased

by increasing the value of C_F . This in turn will slow down the pulse response.

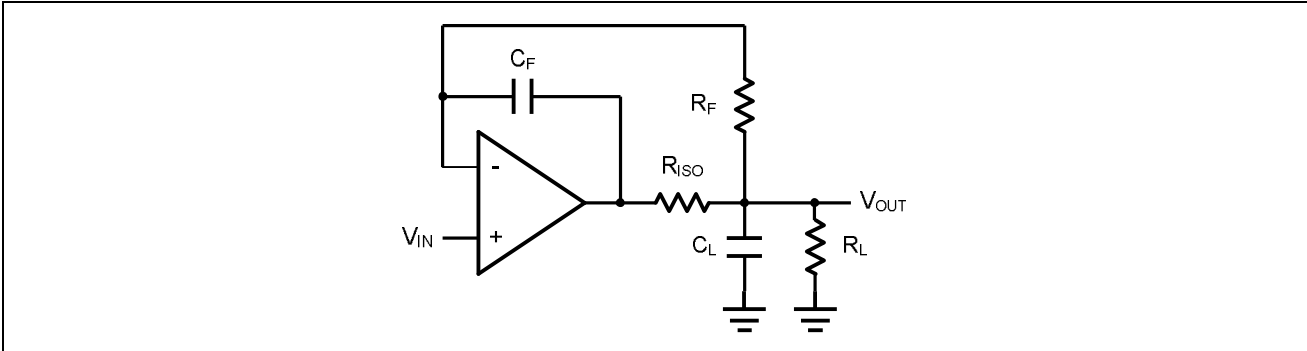

Figure 3. Indirectly Driving a Capacitive Load with DC Accuracy

5.8 Differential amplifier

The differential amplifier allows the subtraction of two input voltages or cancellation of a signal common to the two inputs. It is useful as a computational amplifier in making a differential to single-end conversion or in rejecting a common mode signal. **Figure 4.** shows the differential amplifier using GT7111.

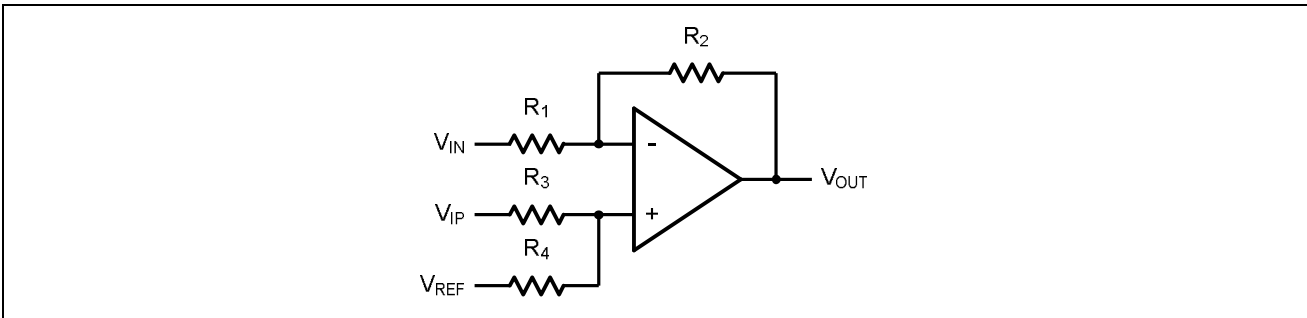

Figure 4. Differential Amplifier

$$V_{OUT} = \left(\frac{R_1+R_2}{R_3+R_4}\right) \frac{R_4}{R_1} V_{IN} - \frac{R_2}{R_1} V_{IP} + \left(\frac{R_1+R_2}{R_3+R_4}\right) \frac{R_3}{R_1} V_{REF}$$

If the resistor ratios are equal (i.e. $R_1=R_3$ and $R_2=R_4$), then

$$V_{OUT} = \frac{R_2}{R_1} (V_{IP} - V_{IN}) + V_{REF}$$



GT7111

5.13 Low Pass Active Filter

The low pass active filter is shown in **Figure 8**. The DC gain is defined by $-R_2/R_1$. The filter has a -20dB/decade roll-off after its corner frequency $f_c=1/(2\pi R_3C_1)$.

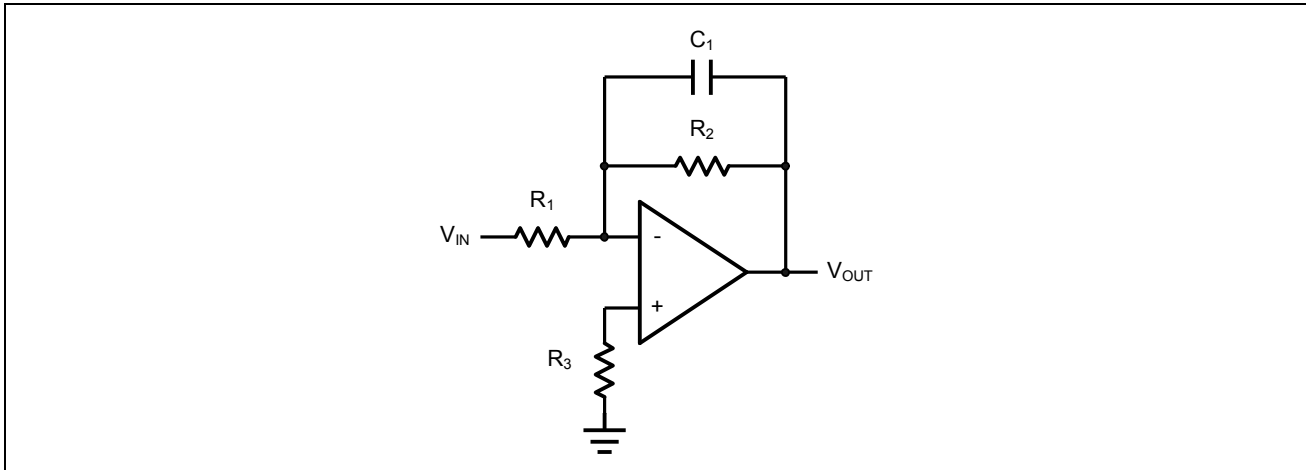

Figure 8. Low Pass Active Filter

5.14 Sallen-Key 2nd Order Active Low-Pass Filter

GT7111 can be used to form a 2nd order Sallen-Key active low-pass filter as shown in **Figure 9**. The transfer function from V_{IN} to V_{OUT} is given by

$$\frac{V_{OUT}}{V_{IN}}(S) = \frac{\frac{1}{C_1 C_2 R_1 R_2} A_{LP}}{S^2 + S \left(\frac{1}{C_1 R_1} + \frac{1}{C_1 R_2} + \frac{1}{C_2 R_2} \right) + \frac{1}{C_1 C_2 R_1 R_2}}$$

Where the DC gain is defined by $A_{LP} = 1 + R_3/R_4$, and the corner frequency is given by

$$\omega_C = \sqrt{\frac{1}{C_1 C_2 R_1 R_2}}$$

The pole quality factor is given by

$$\frac{\omega_C}{Q} = \frac{1}{C_1 R_1} + \frac{1}{C_1 R_2} + \frac{1}{C_2 R_2} - \frac{A_{LP}}{C_2 R_2}$$

Let $R_1=R_2=R$ and $C_1=C_2=C$, the corner frequency and the pole quality factor can be simplified as below

$$\omega_C = \frac{1}{CR}$$

And $Q=2-R_3/R_4$

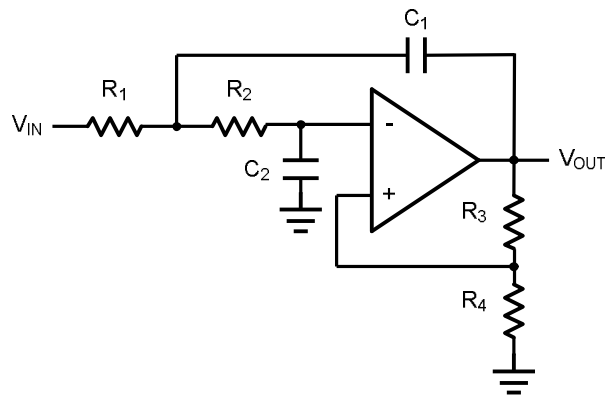

Figure 9. Sallen-Key 2nd Order Active Low-Pass Filter

5.15 Sallen-Key 2nd Order high-Pass Active Filter

The 2nd order Sallen-key high-pass filter can be built by simply interchanging those frequency selective components R_1 , R_2 , C_1 , and C_2 as shown in **Figure 10**.

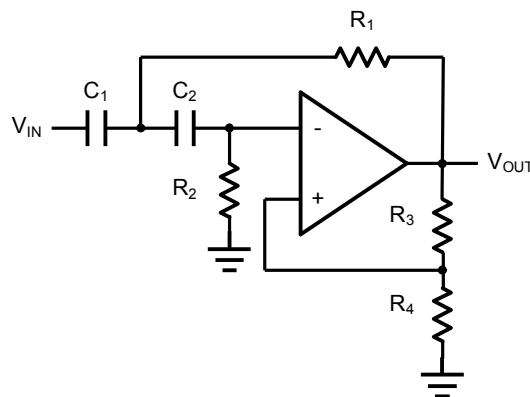

Figure 10. Sallen-Key 2nd Order Active High-Pass Filter

$$\frac{V_{OUT}}{V_{IN}}(S) = \frac{S^2 A_{HP}}{S^2 + S\left(\frac{1}{C_1 R_1} + \frac{1}{C_2 R_2} + \frac{1 - A_{HP}}{C_1 R_1}\right) + \frac{1}{C_1 C_2 R_1 R_2}}$$

Where $A_{HP} = 1 + R_3/R_4$



6. Electrical Characteristics

6.1 Absolute Maximum Ratings

Condition	Min	Max
Power Supply Voltage (V_{DD} to V_{SS})	-0.5V	+7V
Analog Input Voltage ($IN+$ or $IN-$)	$V_{SS}-0.5V$	$V_{DD}+0.5V$
PDB Input Voltage	$V_{SS}-0.5V$	+7V
Operating Temperature Range	-40°C	+125°C
Junction Temperature	+150°C	
Storage Temperature Range	-65°C	+150°C
Lead Temperature (soldering, 10sec)	+300°C	
Package Thermal Resistance ($T_A=+25^\circ C$)		
SOP23-5, θ_{JA}	190°C	
SOP8, θ_{JA}	130°C	

Note: Stress greater than those listed under Absolute Maximum Ratings may cause permanent damage to the device. This is a stress rating only and functional operation of the device at these or any other conditions outside those indicated in the operational sections of this specification are not implied. Exposure to absolute maximum rating conditions for extended periods may affect reliability.



GT7111

6.2 Electrical Characteristics

($V_{DD} = +5V$, $V_{SS} = 0V$, $V_{CM} = 0V$, $V_{OUT} = V_{DD}/2$, $R_L = 100K$ tied to $V_{DD}/2$, $SHDNB = V_{DD}$, $T_A = -40^\circ C$ to $+125^\circ C$, unless otherwise noted. Typical values are at $T_A = +25^\circ C$.) (Notes 1,2)

Parameter	Symbol	Conditions	Min.	Typ.	Max.	Units
Supply-Voltage Range	V_{DD}	Guaranteed by the PSRR test	2.5	-	5.5	V
Quiescent Supply Current (per Amplifier)		$V_{DD} = 5V$	-	2.8	3.5	mA
Input Offset Voltage	V_{OS}	$T_A = 25^\circ C$	-	± 1	-	mV
		$T_A = -40^\circ C \sim +85^\circ C$	-	± 8	-	
		$T_A = -40^\circ C \sim +125^\circ C$	-	-	± 10	
Input Offset Voltage Tempco	$\Delta V_{OS}/\Delta T$		-	± 2	-	$\mu V/^\circ C$
Input Bias Current	I_B	(Note 3)	-	± 10	± 100	pA
Input Offset Current	I_{OS}	(Note 3)	-	± 10	± 100	pA
Input Common-Mode Voltage Range	V_{CM}	Guaranteed by the $T_A = 25^\circ C$ CMRR test, $T_A = -40^\circ C \sim +125^\circ C$	-0.1	-	$V_{DD} + 0.1.5$	V
Common-Mode Rejection Ratio	CMRR	$V_{SS} - 0.1V \leq V_{CM} \leq V_{DD} + 0.1V$ $T_A = 25^\circ C$	-	75	-	dB
		$V_{SS} \leq V_{CM} \leq 5V_{DD}$ $T_A = 25^\circ C$	72	90	-	
		$V_{SS} - 0.1V \leq V_{CM} \leq V_{DD} + 0.1V$ $T_A = -40^\circ C \sim +125^\circ C$	-	68	-	
Power-Supply Rejection Ratio	PSRR	$V_{DD} = +2.5V$ to $+5.5V$	75	90	-	dB
Open-Loop Voltage Gain	A_V	$R_L = 10k\Omega$ to $V_{DD}/2$ $V_{OUT} = 100mV$ to $V_{DD} - 125mV$	90	100	-	dB
		$R_L = 1k\Omega$ to $V_{DD}/2$ $V_{OUT} = 200mV$ to $V_{DD} - 250mV$	80	95	-	
		$R_L = 500\Omega$ to $V_{DD}/2$ $V_{OUT} = 350mV$ to $V_{DD} - 500mV$	70	80	-	
Output Voltage Swing	V_{OUT}	$ V_{IN+} - V_{IN-} \geq 10mV$ $V_{DD} - V_{OH}$	-	10	30	mV
		$R_L = 10k\Omega$ to $V_{DD}/2$ $V_{OL} - V_{SS}$	-	10	35	
		$ V_{IN+} - V_{IN-} \geq 10mV$ $V_{DD} - V_{OH}$	-	80	50	
		$R_L = 1k\Omega$ to $V_{DD}/2$ $V_{OL} - V_{SS}$	-	30	50	
		$ V_{IN+} - V_{IN-} \geq 10mV$ $V_{DD} - V_{OH}$	-	100	140	
		$R_L = 500\Omega$ to $V_{DD}/2$ $V_{OL} - V_{SS}$	-	100	140	
Output Short-Circuit Current	I_{SC}	Sinking or Sourcing	-	± 100	-	mA
-3 dB Gain Bandwidth Product	GBW	$A_V = +1V/V$	-	200	-	MHz
Slew Rate	SR	$A_V = +1V/V$	-	125	-	V/ μs



Parameter	Symbol	Conditions	Min.	Typ.	Max.	Units
Differential Phase error (NTSC)	DP	$G=2, R_L=150\Omega$	-	0.03	-	deg
Differential Gain error (NTSC)	DG	$G=2, R_L=150\Omega$	-	0.09	-	dB
Settling Time	t_s	To 0.01%, $V_{OUT} = 2V$ step $A_V = +1V/V$	-	42	-	ns
Over Load Recovery Time		$V_{IN} \times \text{Gain} = V_S$	-	35	-	ns
Input Voltage Noise Density	e_n	$f = 1\text{MHz}$	-	16	-	nV/ $\sqrt{\text{Hz}}$
Total Harmonic Distortion plus Noise	THD+N	$f_C=5\text{MHz}, V_{OUT}=2V_{p-p}, G=+2$	-	-60	-	dB

Note 1: All devices are 100% production tested at $T_A = +25^\circ\text{C}$; all specifications over the automotive temperature range is guaranteed by design, not production tested.

Note 2: Parameter is guaranteed by design.

Note 3: Peak-to-peak input noise voltage is defined as six times rms value of input noise voltage.



GT7111

6.3 Typical characteristics

0.1dB Gain Flatness vs. Frequency; G=+2

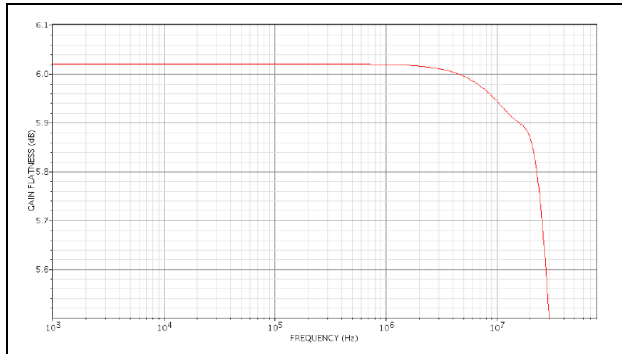

Gain vs. Frequency vs Supply

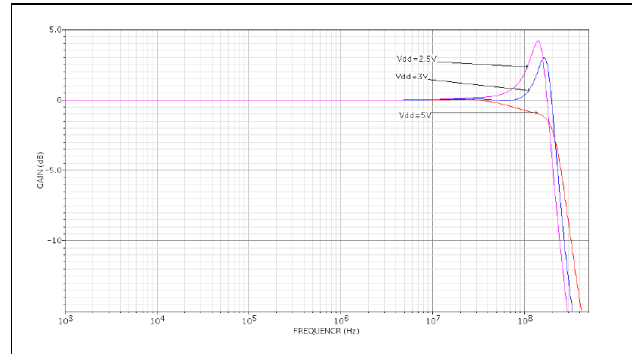

Gain vs. Frequency vs Temperature

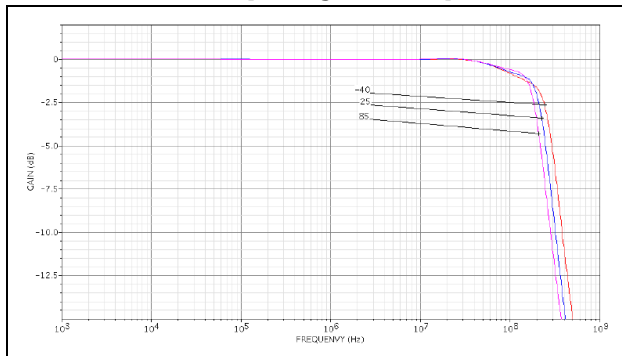

Normalized Gain vs. Frequency; VDD=5V

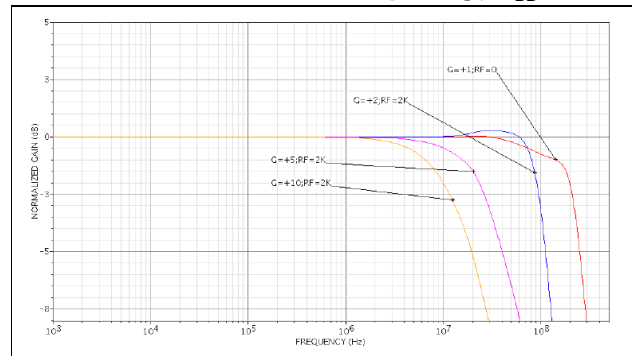

STB_RL=2K

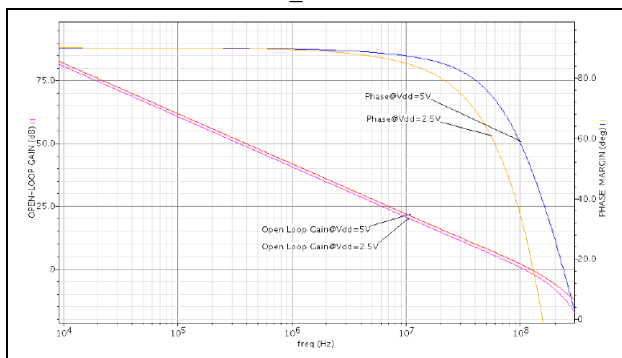



G=+1; RF=2K; V_{pp}=0.2V; V_{DD}=2.5V

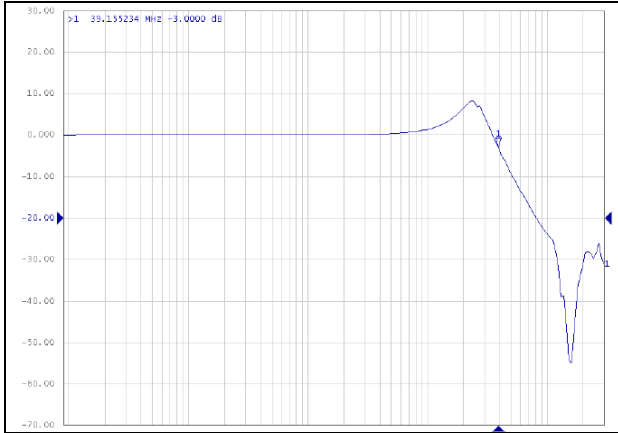

G=+1; RF=2K; V_{pp}=0.2V; V_{DD}=5V

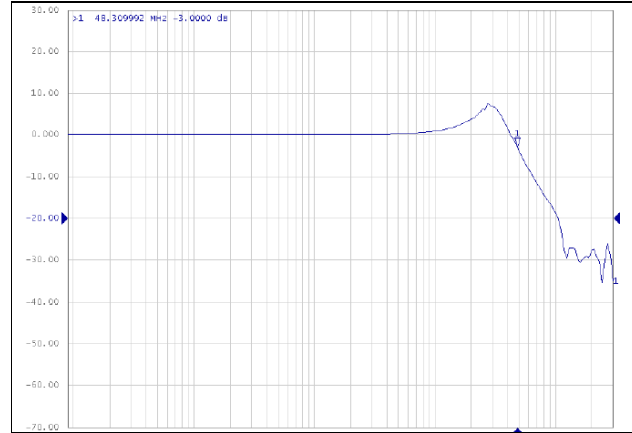

**G=+2; RF=100Ω; RI=150 Ω V_{pp}=0.2V;
V_{DD}=2.5V**

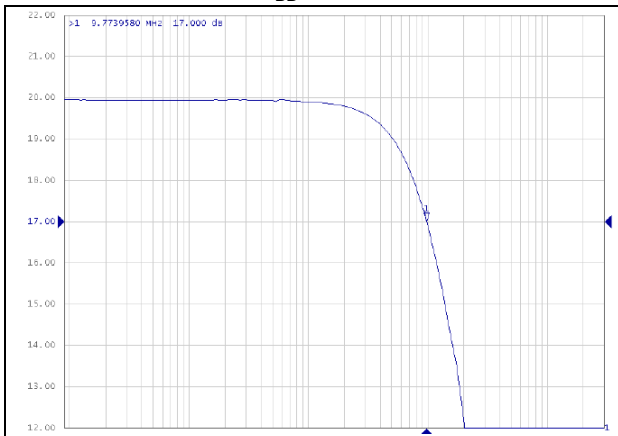

G=-10; RF=2K; V_{pp}=0.2V; V_{DD}=5V

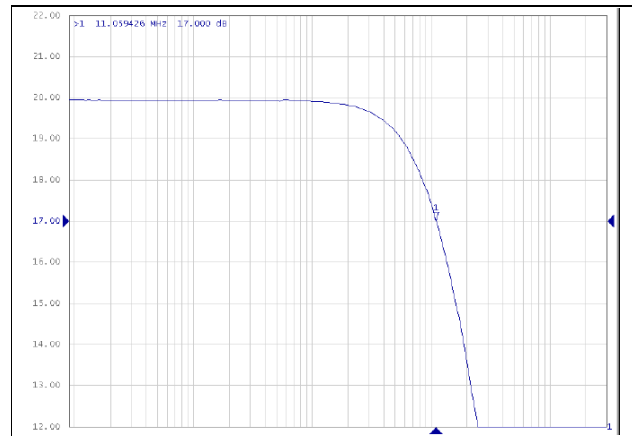

G=+1; RF=2K; V_{pp}=0.2V; V_{DD}=2.5V

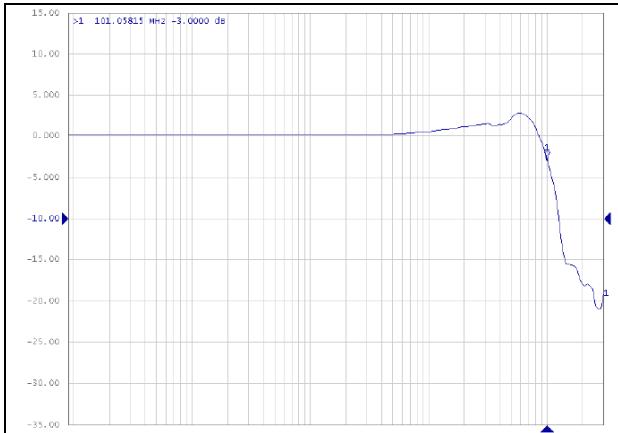

G=+1; RF=2K; V_{pp}=0.2V; V_{DD}=5V

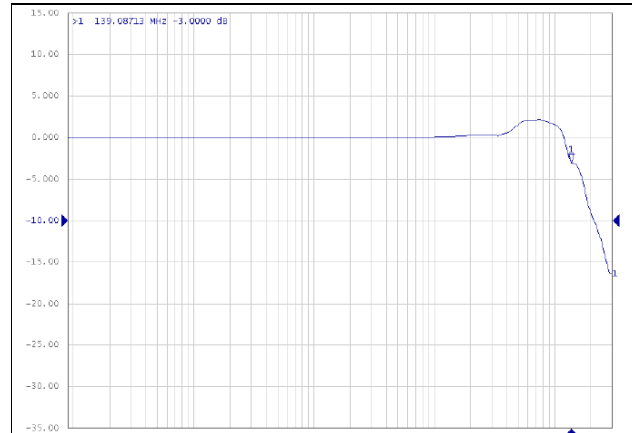



**G=+2; RF=100 Ω; RI=150 Ω V_{pp}=0.2V;
V_{DD}=2.5V**

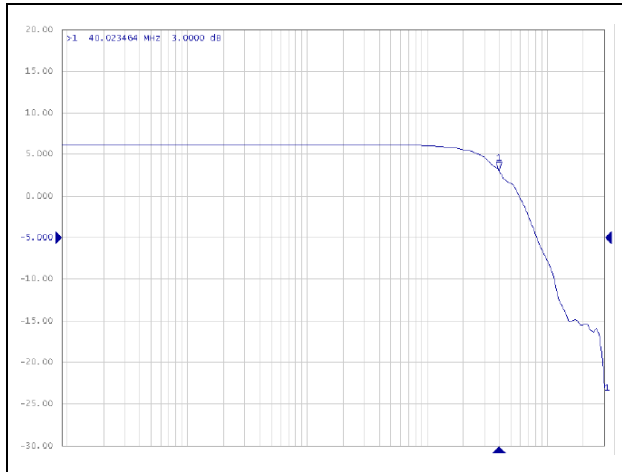

G=+2; RF=100 Ω; RI=150 Ω V_{pp}=0.2V; V_{DD}=5V

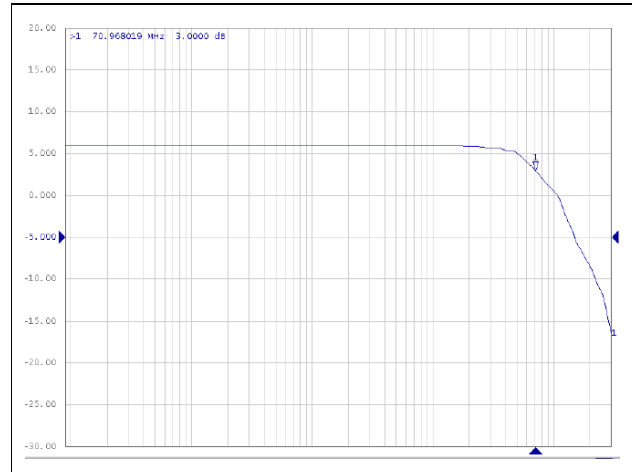

G=+10; RF=2K; V_{pp}=0.2V; V_{DD}=2.5V



G=+10; RF=2K; V_{pp}=0.2V; V_{DD}=5V

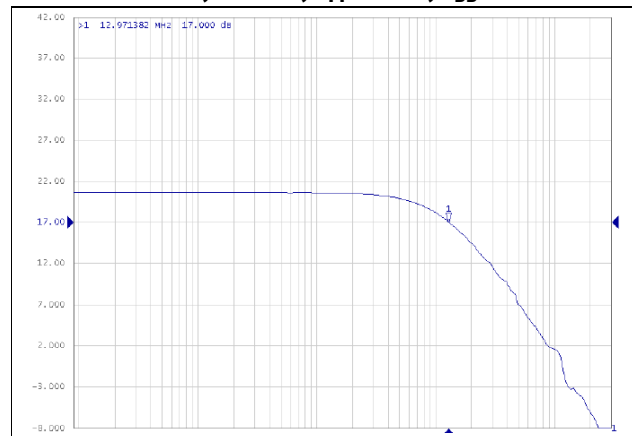



GT7111

Non-Inverting Small Signal Step Response

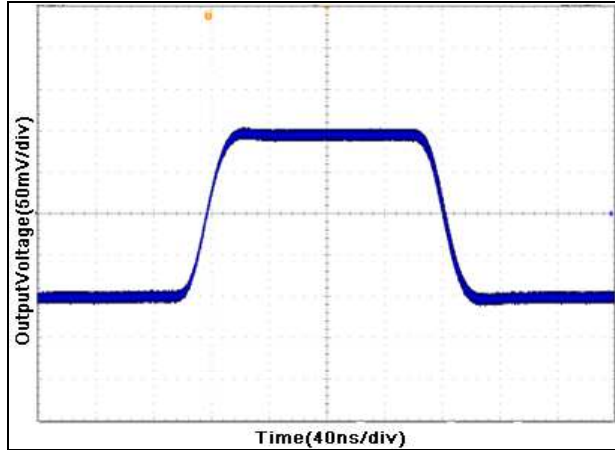

Non-Inverting Large Signal Step Response

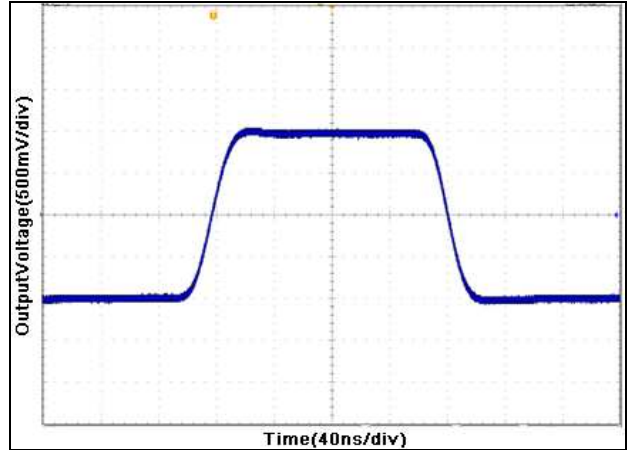

Rail-To-Rail

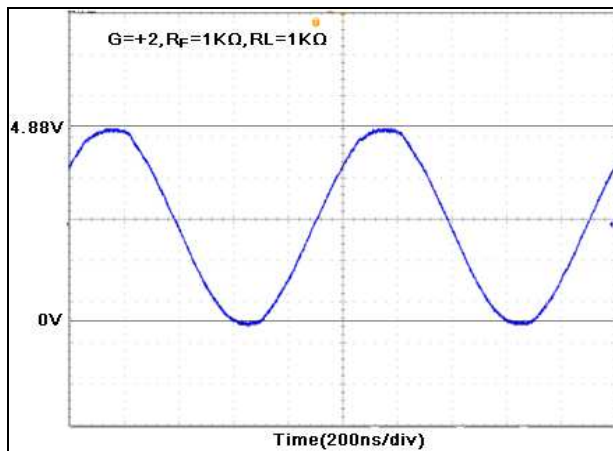

Output Settling Time(large signal)

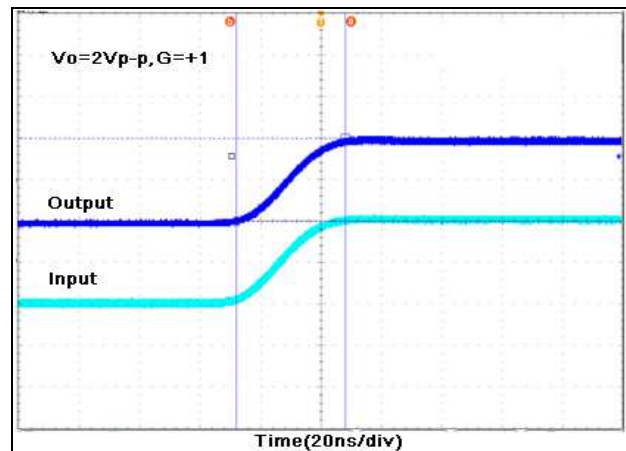

Output Settling Time(small signal)

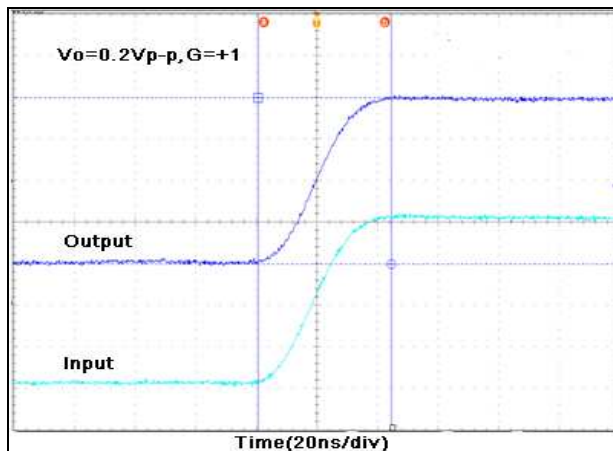

GT7111



7. Ordering Information

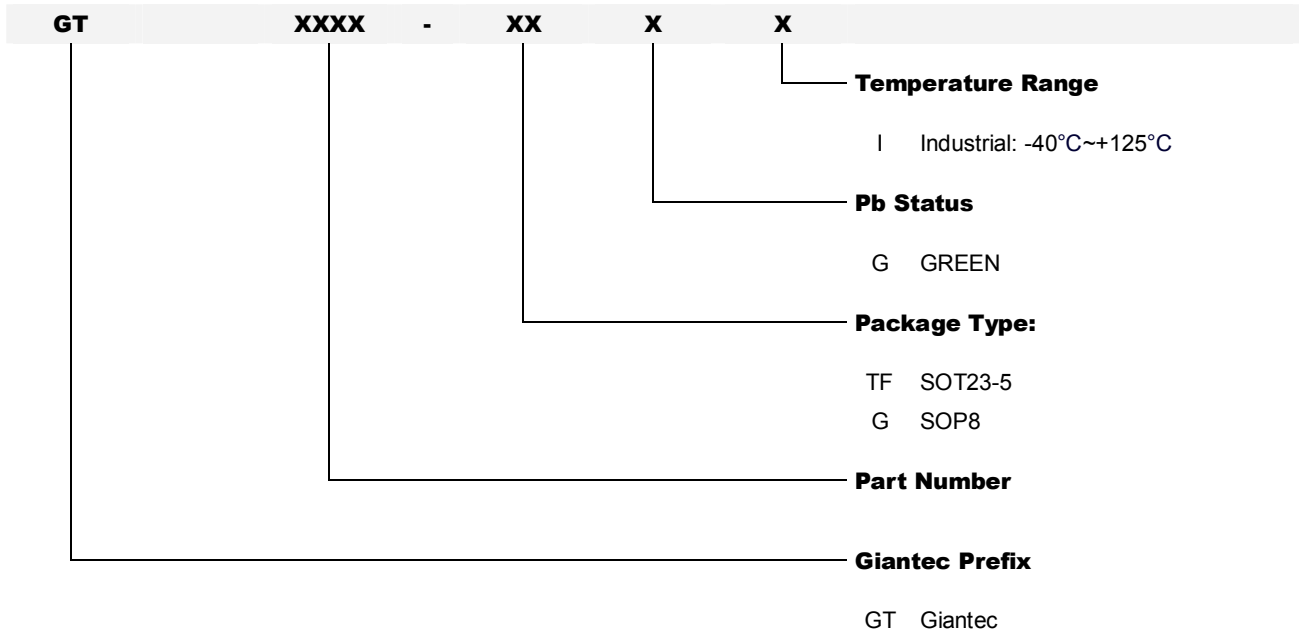

Order Number	Package Description	Package Option
GT7111-TFGI-TR	SOT23-5	Tape and Reel 3000
GT7111-GGI-TR	SOP8	Tape and Reel 4000

GT7111



8. Part Markings

8.1 GT7111-TFGI (Top View)



111	GT7111-TFGI		
●	Pin 1 Indicator		
Y	Seal Year	W	Seal Week
2010 (1st half year)	A	Week 01	A
2010 (2nd half year)	B	Week 02	B
2011 (1st half year)	C	
2011 (2nd half year)	D	Week 26	Z
2012 (1st half year)	E	Week 27	A
2012 (2nd half year)	F	Week 28	B
.....
2022 (2nd half year)	Z	Week 52	Z



GT7111

8.2 GT7111-GGI (Top View)

<u>G</u>	<u>T</u>	<u>7</u>	<u>1</u>	<u>1</u>	<u>1</u>	<u>G</u>	<u>G</u>	<u>I</u>
---	---	---	---	Lot Number		---	---	---
•		<u>Y</u>	<u>Y</u>	<u>W</u>	<u>W</u>	<u>S</u>	<u>V</u>	

GT7111GGI

Lot Number States the last 9 characters of the wafer lot information

• Pin 1 Indicator

YY Seal Year

00 = 2000

01 = 2001

99 = 2099

WW Seal Week

01 = Week 1

02 = Week 2

.

.

.

51 = Week 51

52 = Week 52

S Subcon Code

J = ASESH

L = ASEKS

V Die Version



GT7111

9. Package Information

9.1 SOP23-5

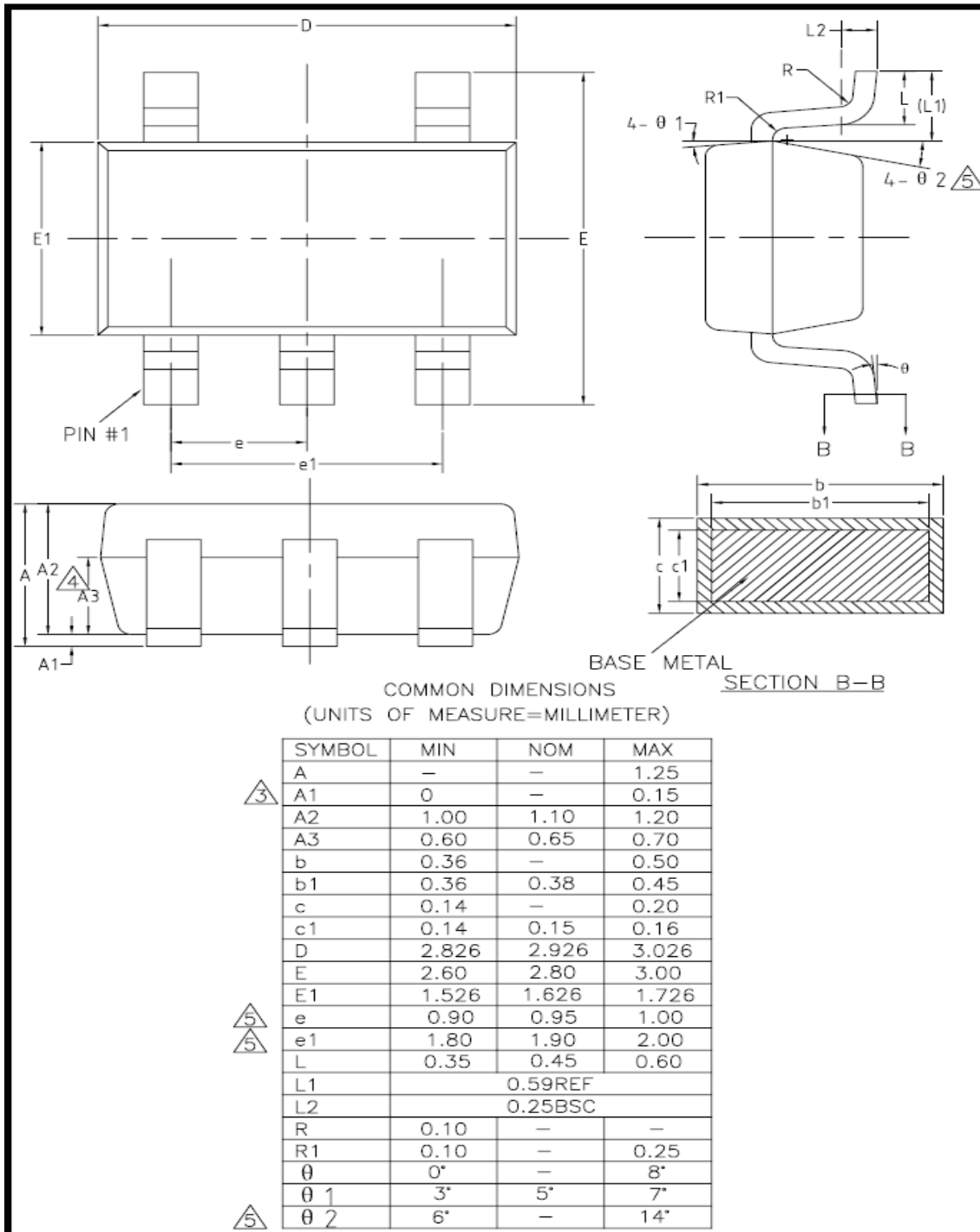



GT7111

9.2 SOP8

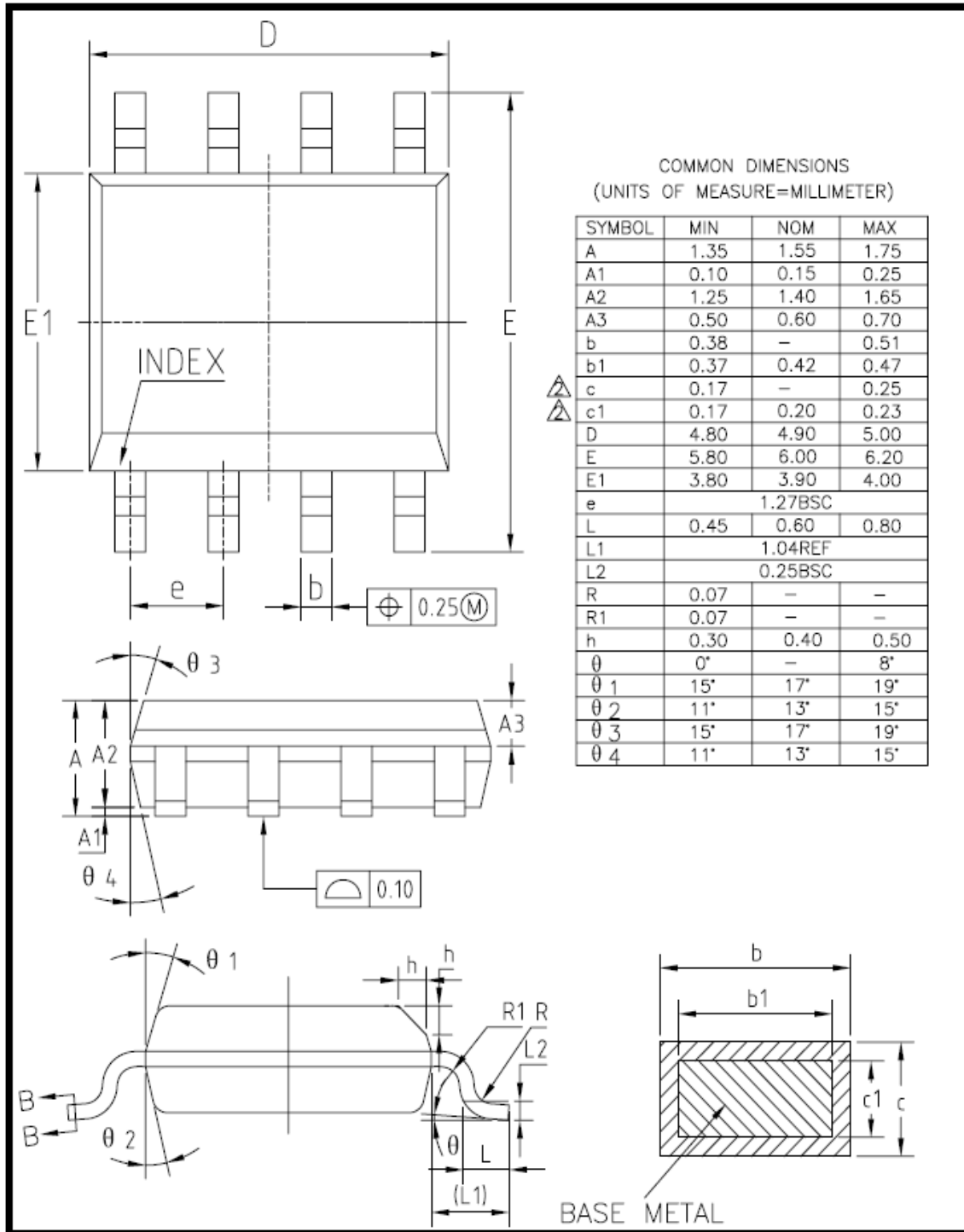



10. Revision History

Revision	Date	Descriptions
A0	Sept.,2011	Initial Version