

GT7041



Super Low power, CMOS, Rail-to-Rail Operational Amplifier

Advanced

1. Features

- Single-Supply Operation from +1.4V to +5.5V
- Rail-to-Rail Input/Output
- Gain-Bandwidth Product: 9KHz
- Low Input Bias Current: 1pA
- Low Offset Voltage: 1mV
- Quiescent Current: 400nA
- Available in Space-Saving Packages:
- SOP-8 and SOT23-5 Packages

2. General Description

The GT7041 series amplifiers are single supply, low power CMOS dual operational amplifier, these amplifiers offer bandwidth of 9KHz, rail-to-rail inputs and outputs, and single-supply operation from 1.4V to 5.5V. Low quiescent supply current of 1 μ A and very low input bias current of 1pA make the devices an ideal choice for low offset, low power consumption and high impedance applications such as smoke detectors, photodiode amplifiers, and other sensors.

The GT7041 is available in SOP-8 and SOT23-5 packages. The extended temperature range of -40°C to +85°C over all supply voltages offers additional design flexibility.

3. Applications

- Portable Equipment
- Mobile Communications
- Smoke Detector
- Sensor Interface
- Medical Instrumentation
- Battery-Powered Instruments
- Handheld Test Equipment

4. Pin Configuration

4.1 GT7041 SOP8 and SOT23-5 (Top View)

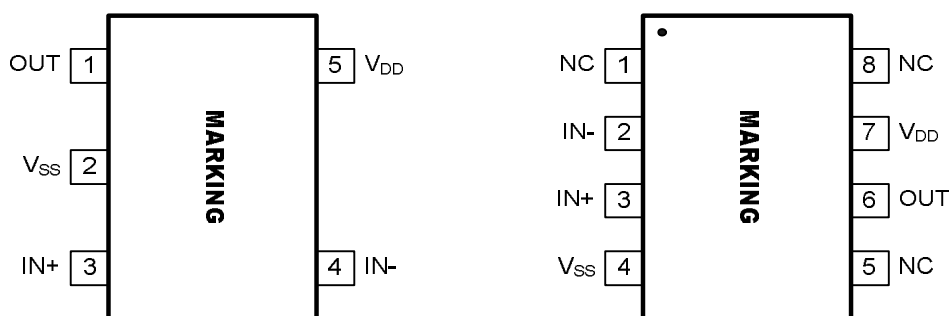

Figure 1. Pin Assignment Diagram (SOP8 and SOT23-5 Package)

Note: Please see section “Part Markings” for detailed Marking Information.

Copyright © 2010 Giantec Semiconductor Inc. (Giantec). All rights reserved. Giantec reserves the right to make changes to this specification and its products at any time without notice. Giantec products are not designed, intended, authorized or warranted for use as components in systems or equipment intended for critical medical or surgical equipment, aerospace or military, or other applications planned to support or sustain life. It is the customer's obligation to optimize the design in their own products for the best performance and optimization on the functionality and etc. Giantec assumes no liability arising out of the application or use of any information, products or services described herein. Customers are advised to obtain the latest version of this device specification before relying on any published information and prior placing orders for products.



GT7041

5. Application Information

5.1 Size

GT7041 series op amps are unity-gain stable and suitable for a wide range of general-purpose applications. The small footprints of the GT7041 series packages save space on printed circuit boards and enable the design of smaller electronic products.

5.2 Power Supply Bypassing and Board Layout

GT7041 series operates from a single 1.4V to 5.5V supply or dual $\pm 0.7V$ to $\pm 2.75V$ supplies. For best performance, a $0.1\mu F$ ceramic capacitor should be placed close to the V_{DD} pin in single supply operation. For dual supply operation, both V_{DD} and V_{SS} supplies should be bypassed to ground with separate $0.1\mu F$ ceramic capacitors.

5.3 Low Supply Current

The low supply current ($1.4\mu A$) of GT7041 series will help to maximize battery life. They are ideal for battery powered systems

5.4 Operating Voltage

GT7041 series operate under wide input supply voltage (1.4V to 5.5V). In addition, all temperature specifications apply from $-40^{\circ}C$ to $+125^{\circ}C$. Most behavior remains unchanged throughout the full operating voltage range. These guarantees ensure operation throughout the single Li-Ion battery lifetime

5.5 Rail-to-Rail Input

The input common-mode range of GT7041 series extends 100mV beyond the supply rails ($V_{SS}-0.1V$ to $V_{DD}+0.1V$). This is achieved by using complementary input stage. For normal operation, inputs should be limited to this range.

5.6 Rail-to-Rail Output

Rail-to-Rail output swing provides maximum possible dynamic range at the output. This is particularly important when operating in low supply voltages. The output voltage of GT7041 series can typically swing to less than 10mV from supply rail in light resistive loads ($>100k\Omega$), and 60mV of supply rail in moderate resistive loads ($10k\Omega$).

5.7 Capacitive Load Tolerance

The GT7041 series can directly drive 250pF capacitive load in unity-gain without oscillation. Increasing the gain enhances the amplifier's ability to drive greater capacitive loads. In unity-gain configurations, the capacitive load drive can be improved by inserting an isolation resistor R_{ISO} in series with the capacitive load, as shown in Figure 1.

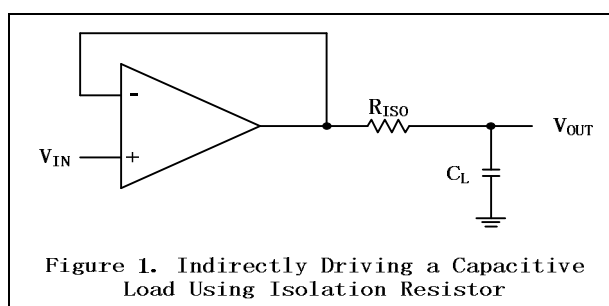

The bigger the R_{ISO} resistor value, the more stable V_{OUT} will be. However, if there is a resistive load R_L in parallel with the capacitive load, a voltage divider (proportional to R_{ISO}/R_L) is formed, this will result in a gain error.

The circuit in Figure 2 is an improvement to the one in Figure 1. R_F provides the DC accuracy by feed-forward the V_{IN} to R_L . C_F and R_{ISO} serve to counteract the loss of phase margin by feeding the high frequency component of the output signal back to the amplifier's inverting input, thereby preserving the phase margin in the overall feedback loop. Capacitive drive can be increased by increasing the value of C_F . This in turn will slow down the pulse response.

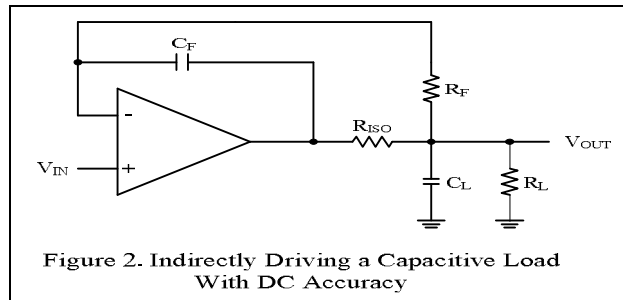

5.8 Differential amplifier

The differential amplifier allows the subtraction of two input voltages or cancellation of a signal common to the two inputs. It is useful as a computational amplifier in making a differential to single-end conversion or in rejecting a common mode signal. Figure 3 shows the differential amplifier using GT7041.

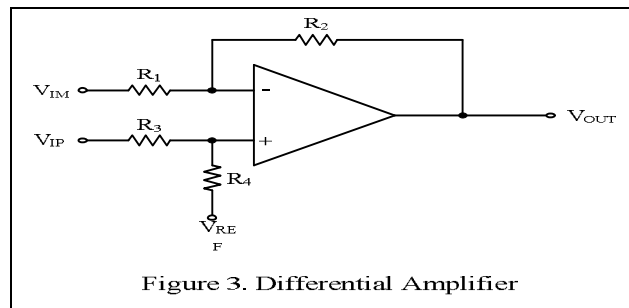

$$V_{out} = \left(\frac{R_1+R_2}{R_3+R_4}\right) \frac{R_4}{R_1} V_2 - \frac{R_2}{R_1} V_1 + \left(\frac{R_1+R_2}{R_3+R_4}\right) \frac{R_3}{R_1} \frac{V^+}{2}$$

If the resistor ratios are equal (i.e. $R_1=R_3$ and $R_2=R_4$), then

$$V_{out} = \frac{R_2}{R_1} (V_2 - V_1) + \frac{V^+}{2}$$

5.9 Instrumentation Amplifier

The input impedance of the previous differential amplifier is set by the resistors R_1 , R_2 , R_3 , and R_4 . To maintain the high input impedance, one can use a voltage follower in front of each input as shown in the following two instrumentation amplifiers.

5.10 Three-Op-Amp Instrumentation Amplifier

The quad GT7041 can be used to build a three-op-amp instrumentation amplifier as shown in Figure 4.

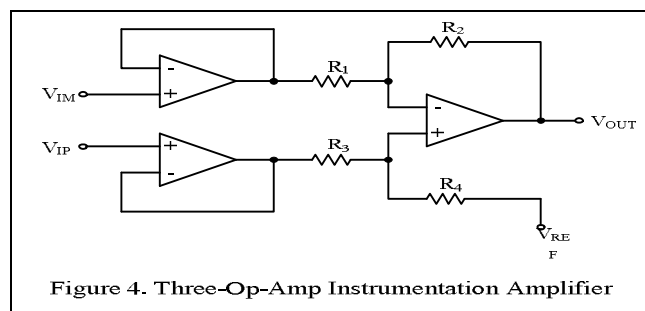

The amplifier in Figure 4 is a high input impedance differential amplifier with gain of R_2/R_1 . The two differential voltage



GT7041

followers assure the high input impedance of the amplifier.

5.11 Two-Op-Amp Instrumentation Amplifier

GT7041 can also be used to make a high input impedance two-op-amp instrumentation amplifier as shown in Figure 5.

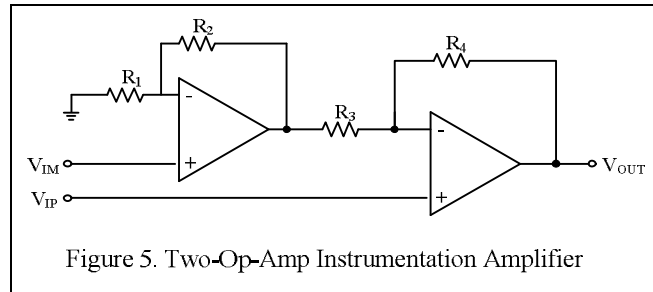

$$V_o = (1 + \frac{R_4}{R_3})(V_2 - V_1)$$

Where $R_1=R_3$ and $R_2=R_4$. If all resistors are equal, then $V_o=2(V_2-V_1)$

5.12 Single-Supply Inverting Amplifier

The inverting amplifier is shown in Figure 6. The capacitor C_1 is used to block the DC signal going into the AC signal source V_{IN} . The value of R_1 and C_1 set the cut-off frequency to $f_c=1/(2\pi R_1 C_1)$. The DC gain is defined by $V_{OUT}=-R_2/R_1 V_{IN}$

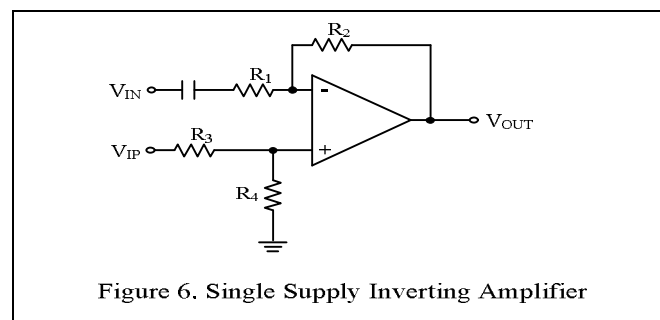

5.13 Low Pass Active Filter

The low pass active filter is shown in Figure 7. The DC gain is defined by $-R_2/R_1$. The filter has a -20dB/decade roll-off after its corner frequency $f_c=1/(2\pi R_3 C_1)$.

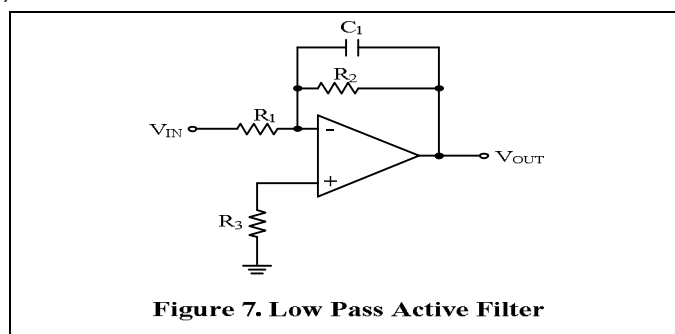

5.14 Sallen-Key 2nd Order Active Low-Pass Filter

GT7041 can be used to form a 2nd order Sallen-Key active low-pass filter as shown in Figure 8. The transfer function from V_{IN} to



GT7041

V_{OUT} is given by

$$\frac{V_{OUT}}{V_{in}}(S) = \frac{\frac{1}{C_1 C_2 R_1 R_2} A_{LP}}{S^2 + S\left(\frac{1}{C_1 R_1} + \frac{1}{C_1 R_2} + \frac{1}{C_2 R_2} - \frac{A_{LP}}{C_2 R_2}\right) + \frac{1}{C_1 C_2 R_1 R_2}}$$

Where the DC gain is defined by $A_{LP} = 1 + R_3/R_4$, and the corner frequency is given by $\omega_C = \sqrt{\frac{1}{C_1 C_2 R_1 R_2}}$

The pole quality factor is given by $\frac{\omega_C}{Q} = \frac{1}{C_1 R_1} + \frac{1}{C_1 R_2} + \frac{1}{C_2 R_2} - \frac{A_{LP}}{C_2 R_2}$

Let $R_1 = R_2 = R$ and $C_1 = C_2 = C$, the corner frequency and the pole quality factor can be simplified as below

$$\omega_C = \frac{1}{CR} \text{ And } Q = 2 - R_3/R_4$$

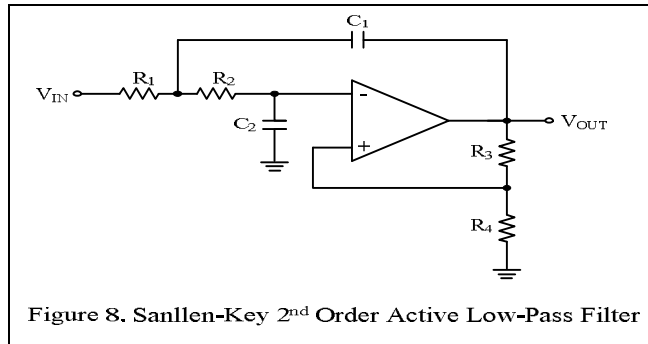

Figure 8. Sallen-Key 2nd Order Active Low-Pass Filter

5.15 Sallen-Key 2nd Order high-Pass Active Filter

The 2nd order Sallen-key high-pass filter can be built by simply interchanging those frequency selective components R_1 , R_2 , C_1 , and C_2 as shown in Figure 9.

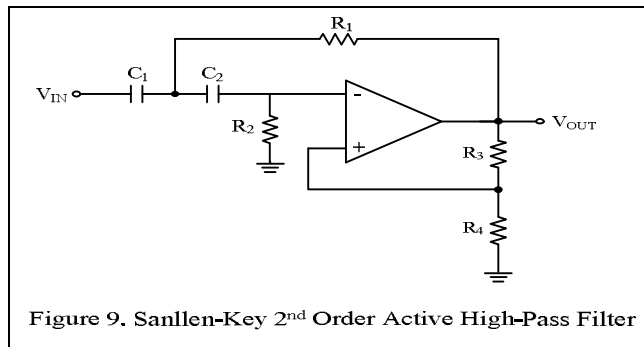

Figure 9. Sallen-Key 2nd Order Active High-Pass Filter

$$\frac{V_{OUT}}{V_{IN}}(S) = \frac{S^2 A_{HP}}{S^2 + S\left(\frac{1}{C_1 R_1} + \frac{1}{C_2 R_2} + \frac{1 - A_{HP}}{C_1 R_1}\right) + \frac{1}{C_1 C_2 R_1 R_2}}$$

Where $A_{HP} = 1 + R_3/R_4$



GT7041

6. Electrical Characteristics

6.1 Absolute Maximum Ratings

Condition	Min	Max
Power Supply Voltage (V_{DD} to V_{SS})	-0.5V	+7V
Analog Input Voltage ($IN+$ or $IN-$)	$V_{SS}-0.5V$	$V_{DD}+0.5V$
PDB Input Voltage	$V_{SS}-0.5V$	+7V
Operating Temperature Range	-40°C	+85°C
Junction Temperature	+150°C	
Storage Temperature Range	-65°C	+150°C
Lead Temperature (soldering, 10sec)	+300°C	
Package Thermal Resistance ($T_A=+25^\circ C$)		
MSOP-8, θ_{JA}	210°C	
SOP8, θ_{JA}	130°C	

Note: Stress greater than those listed under Absolute Maximum Ratings may cause permanent damage to the device. This is a stress rating only and functional operation of the device at these or any other conditions outside those indicated in the operational sections of this specification are not implied. Exposure to absolute maximum rating conditions for extended periods may affect reliability.



GT7041

6.2 Electrical Characteristics

($V_{DD} = +5V$, $V_{SS} = 0V$, $V_{CM} = V_{DD}/2$, $V_{OUT} = V_{DD}/2$, $R_L = 100K$ tied to $V_{DD}/2$, $SHDNB = V_{DD}$, $T_A = -40^{\circ}C$ to $85^{\circ}C$, unless otherwise noted. Typical values are at $T_A = +25^{\circ}C$.) (Notes 1)

PARAMETER	SYMBOL	CONDITIONS	MIN	TYP	MAX	UNIS
Supply-Voltage Range	V_{DD}	Guaranteed by the PSRR test	1.4		5.5	V
Quiescent Supply Current (per Amplifier)	I_Q	$V_{DD} = 5V$ Shutdown Mode ($PDB = V_{SS}$)		1.0 0.1	2.0	μA μA
Input Offset Voltage	V_{OS}			1	± 5	mV
Input Offset Voltage Tempco	$\Delta V_{OS}/\Delta T$			0.5		$\mu V/^{\circ}C$
Input Bias Current	I_B	(Note 2)		1		pA
Input Offset Current	I_{OS}	(Note 2)		1		pA
Input Common-Mode Voltage Range	V_{CM}		-0.1		$V_{DD}+0.1$	V
Common-Mode Rejection Ratio	CMRR	$V_{DD}=5.5$ $V_{SS}-0.1V \leq V_{CM} \leq V_{DD}+0.1V$ $V_{SS} \leq V_{CM} \leq 5V$	60 65	75 80		dB
Power-Supply Rejection Ratio	PSRR	$V_{DD} = +1.8V$ to $+5.5V$	65	80		dB
Open-Loop Voltage Gain	A_V	$V_{DD}=5V$, $R_L=50k\Omega$, $0.1V \leq V_O \leq 4.9V$ $V_{DD}=1.4V$, $R_L=50k\Omega$, $0.1V \leq V_O \leq 4.9V$		90 80		dB dB
Output Voltage Swing	V_{OUT}	$ V_{IN+}-V_{IN-} \geq 10mV$ $V_{DD}-V_{OH}$ $R_L = 100k\Omega$ to $V_{DD}/2$ $V_{OL}-V_{SS}$ $ V_{IN+}-V_{IN-} \geq 10mV$ $V_{DD}-V_{OH}$ $R_L = 50k\Omega$ to $V_{DD}/2$ $V_{OL}-V_{SS}$		6 6 40 40		mV
Output Short-Circuit Current	I_{SC}	Sinking or Sourcing		± 3		mA
Gain Bandwidth Product	GBW	$A_V = +1V/V$		9		KHz
Slew Rate	SR	$A_V = +1V/V$		4.5		V/ms
Settling Time	t_s	To 0.1%, $V_{OUT} = 2V$ step $A_V = +1V/V$		650		μs
Input Voltage Noise Density	e_n	$V_{DD}=5V$, $f = 1kHz$ $V_{DD}=1.4V$, $f = 1kHz$		150 150		nV/ \sqrt{Hz}

Note 1: All devices are 100% production tested at $T_A = 25^{\circ}C$; all specifications over the automotive temperature range is guaranteed by design, not production tested.

Note 2: Parameter is guaranteed by design.



GT7041

6.3 Typical performance characteristics

$T_A = +25^\circ\text{C}$, $V_{DD} = +5\text{V}$, $V_{SS} = 0\text{V}$, $V_{CM} = V_{DD}/2$, $V_{OUT} = V_{DD}/2$, $R_L = 100\text{K}$ tied to $V_{DD}/2$, $C_L = 60\text{pF}$, unless otherwise noted.

Large Signal Inverting Pulse Response

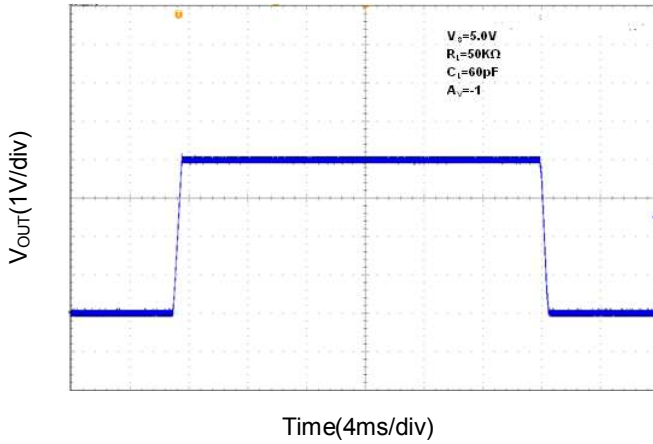

Large Signal Non-Inverting Pulse Response

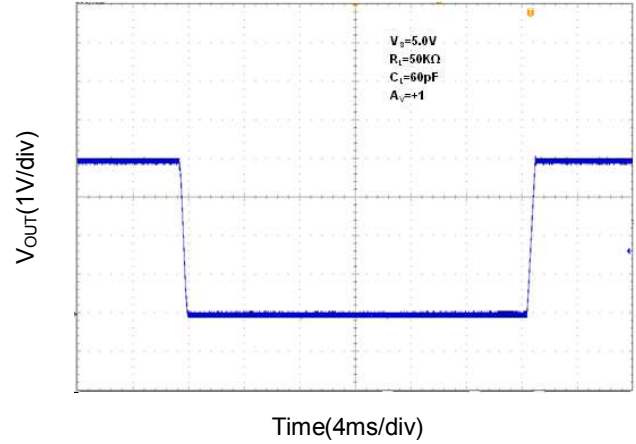

Small Signal Inverting Pulse Response

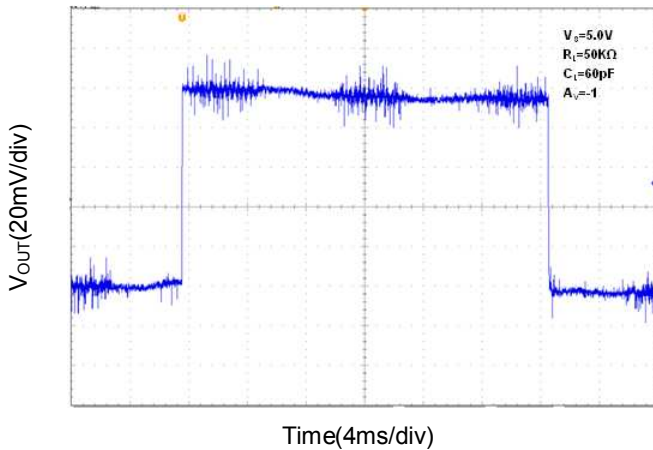

Small Signal Non-Inverting Pulse Response

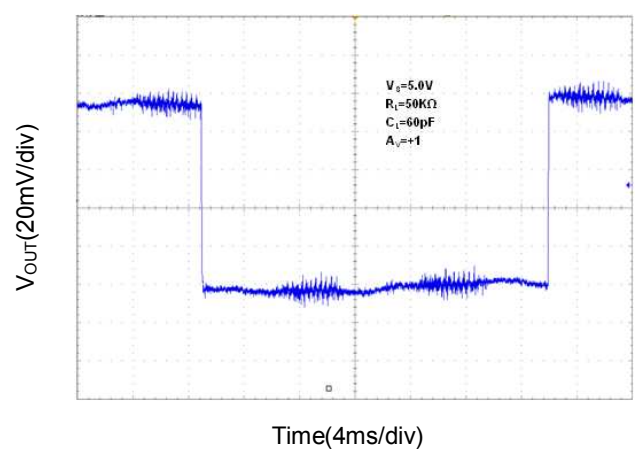



GT7041

No Phase Reversal

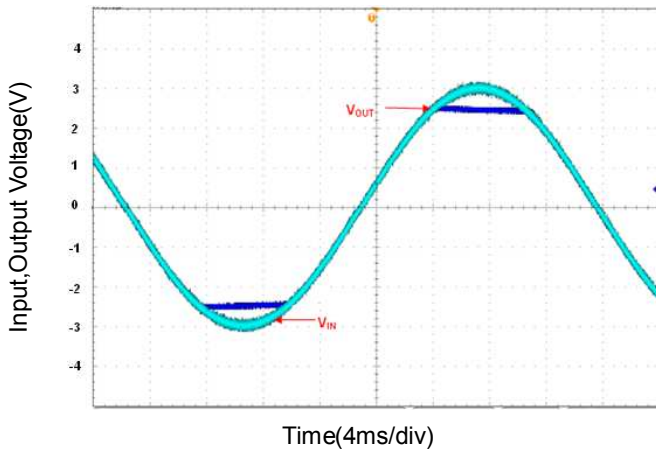

Slew Rate vs. Temperature

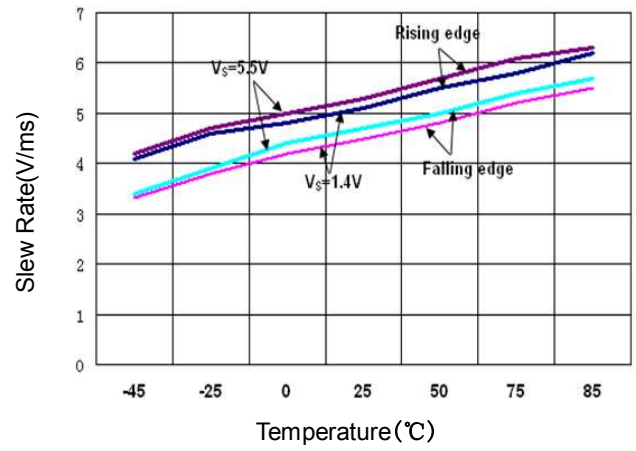

Output Settling Time

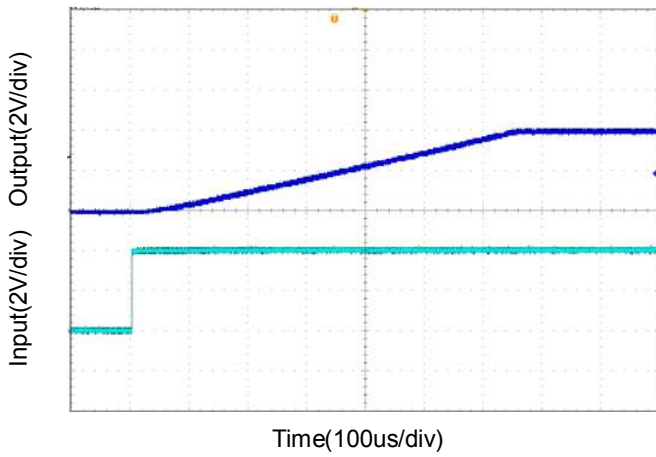



GT7041

8.2 GT7041-GGI (Top View)

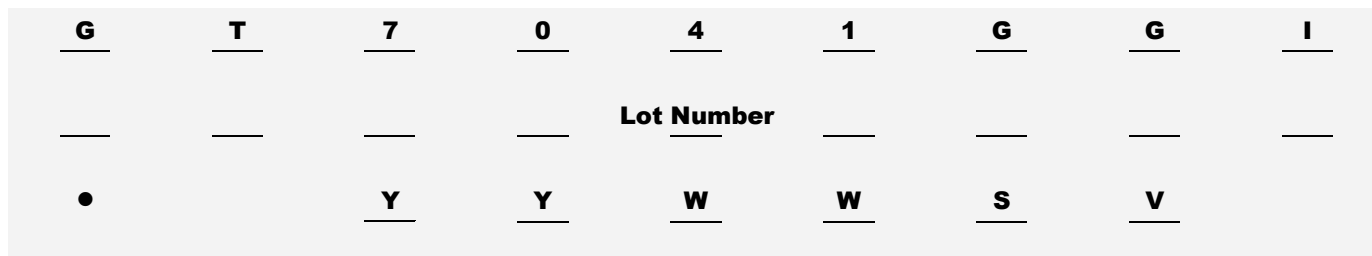

GT7041GGI

Lot Number States the last 9 characters of the wafer lot information

• Pin 1 Indicator

YY Seal Year

00 = 2000

01 = 2001

99 = 2099

WW Seal Week

01 = Week 1

02 = Week 2

.

.

.

51 = Week 51

52 = Week 52

S Subcon Code

J = ASESH

L = ASEKS

V Die Version



GT7041

9. Package Information

9.1 SOT23-5

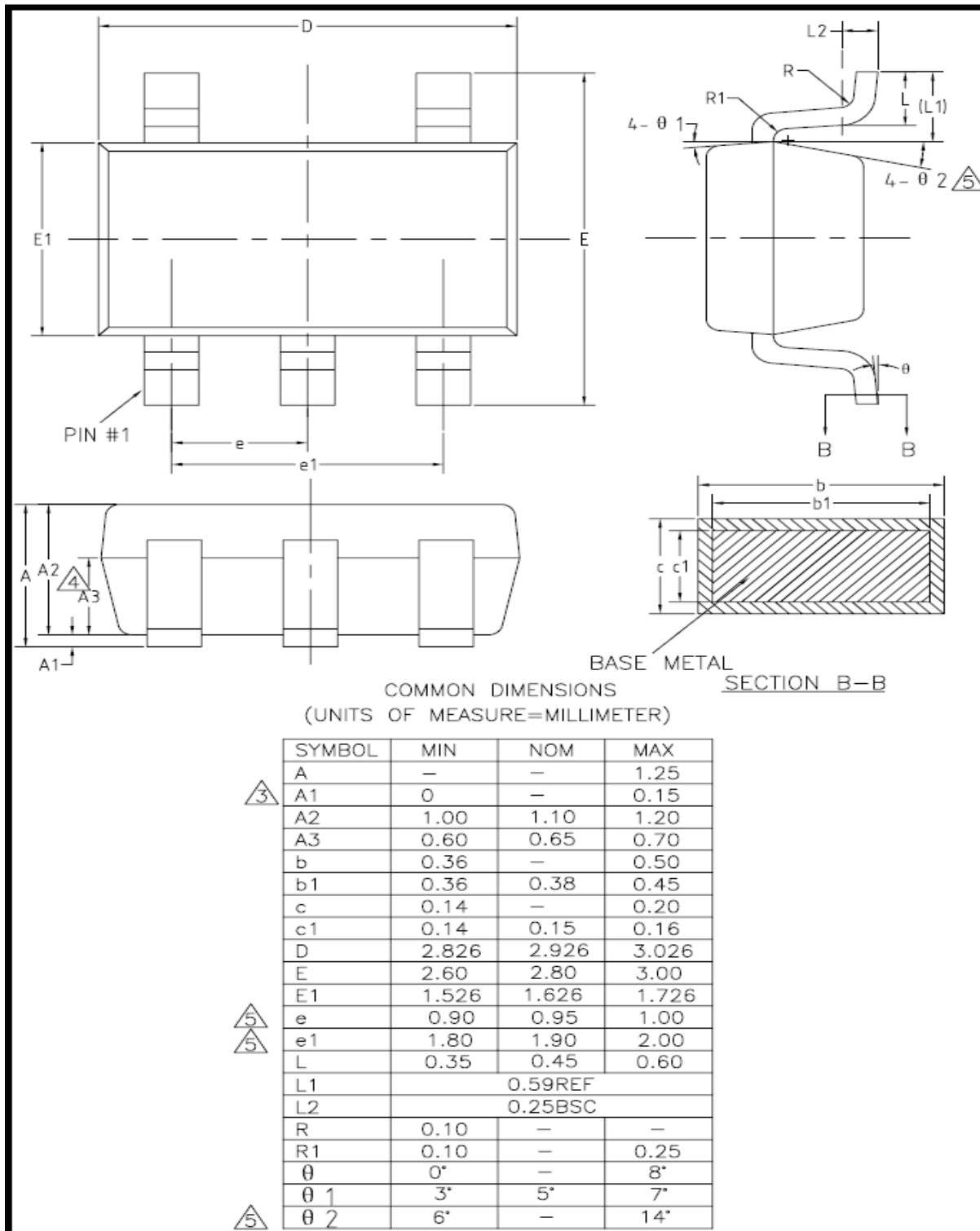



GT7041

9.2 SOP8

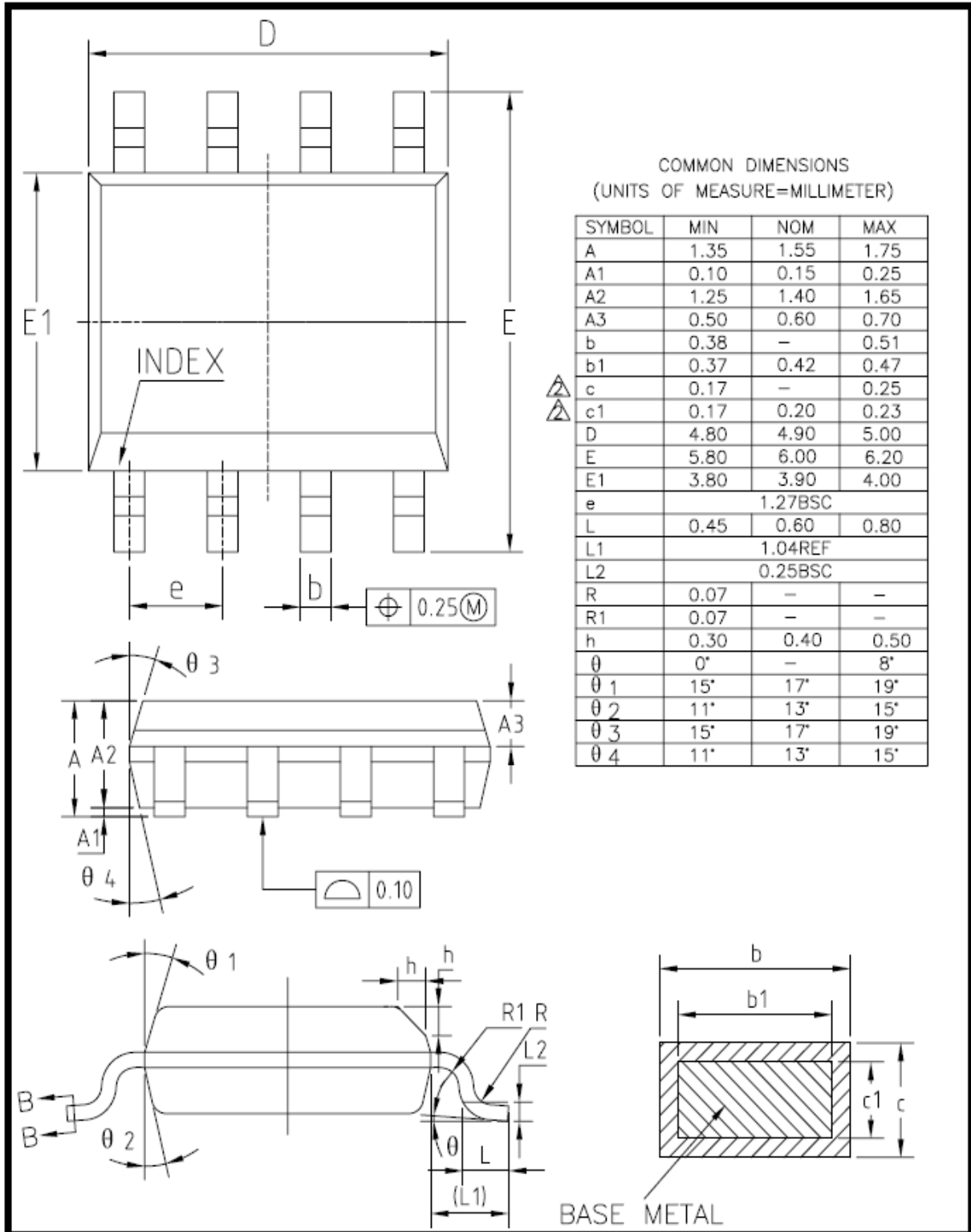



GT7041

10. Revision History

Revision	Date	Descriptions
A0	July,2013	Version 0