

GT5315



1.2A, Constant Current LED Driver with Internal Switch

Advanced

1. Features

- Simple low parts count
- Up to 1.2A output current
- Single pin on/off and brightness control
- using DC voltage or PWM
- PWM resolution up to 5000:1
- Soft start capability
- High efficiency (up to 98%)
- Wide input voltage range: 6V to 40V
- 48V transient capability
- Low power shutdown
- Up to 2MHz switching frequency
- Inherent open-circuit LED protection
- Typical 1.5% output current accuracy
- Operating Temperature: -40°C ~ +125°C
- SOT89-5 Package

2. General Description

The GT5315 is a continuous mode inductive step-down converter, designed for driving single or multiple series connected LEDs efficiently from a voltage source higher than the LED voltage. The device operates from an input supply between 6V and 40V and provides an externally adjustable output current of up to 1.2A. Depending upon supply voltage and external components, this can provide up to 48 watts of output power.

The GT5315 includes the output switch and a high-side output current sensing circuit, which uses an external resistor to set the nominal average output current. Output current can be adjusted above, or below the set value, by

applying an external control signal to the 'ADJ' pin. The ADJ pin will accept either a DC voltage or a PWM waveform. Depending upon the control frequency, this will provide either a continuous (dimmed) or a gated output current. Soft-start can be forced using an external capacitor from the ADJ pin to ground.

Applying a voltage of 0.2V or lower to the ADJ pin turns the output off and switches the device into a low current standby state.

3. Applications

- Low voltage halogen replacement LEDs
- Automotive lighting
- Low voltage industrial lighting
- LED back-up lighting
- Illuminated signs
- Emergency lighting
- SELV lighting
- LCD TV backlighting

Copyright © 2010 Giantec Semiconductor Inc. (Giantec). All rights reserved. Giantec reserves the right to make changes to this specification and its products at any time without notice. Giantec products are not designed, intended, authorized or warranted for use as components in systems or equipment intended for critical medical or surgical equipment, aerospace or military, or other applications planned to support or sustain life. It is the customer's obligation to optimize the design in their own products for the best performance and optimization on the functionality and etc. Giantec assumes no liability arising out of the application or use of any information, products or services described herein. Customers are advised to obtain the latest version of this device specification before relying on any published information and prior placing orders for products.



GT5315

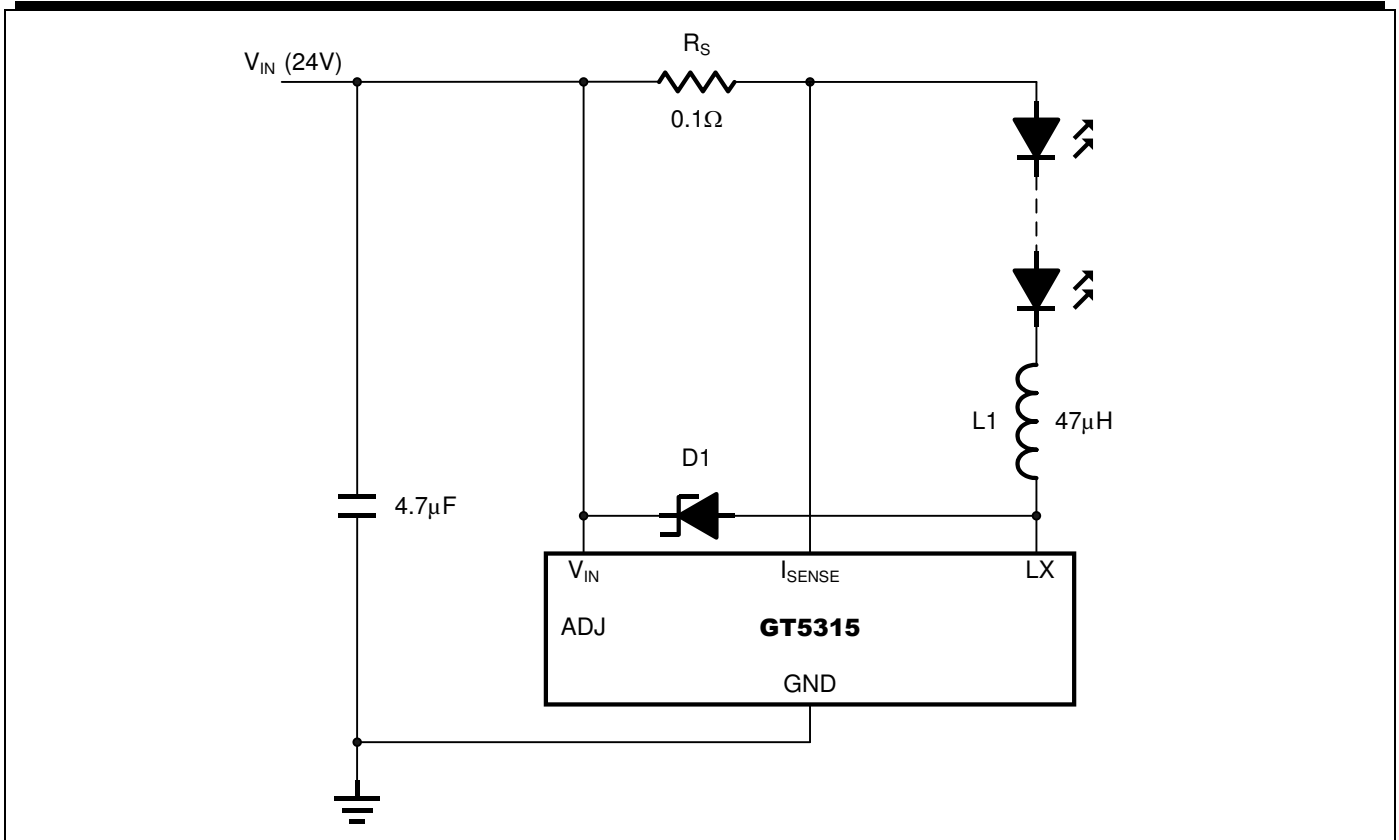

Figure 1. Typical Application Circuit



GT5315

4. Functional Block Diagram

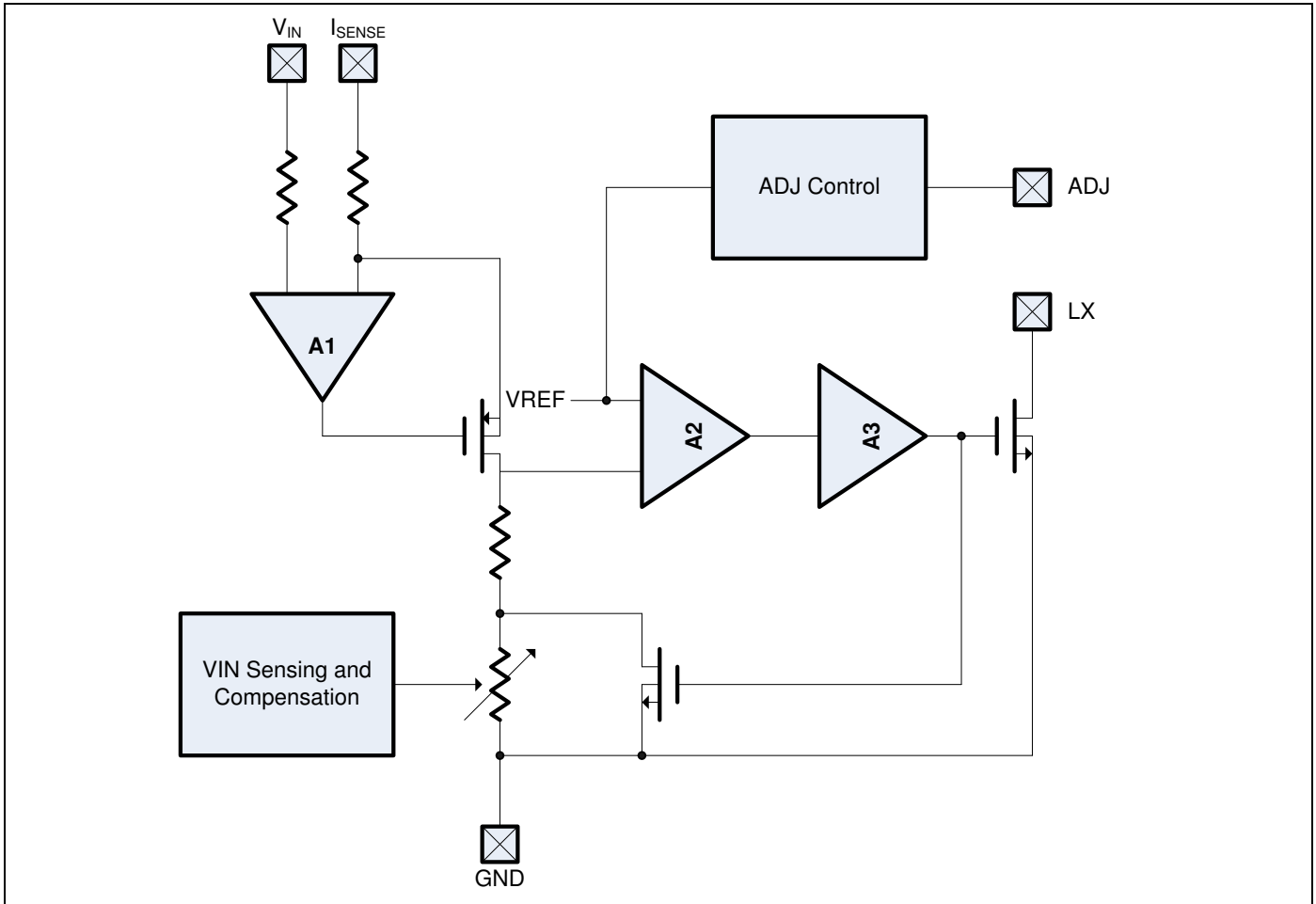

Figure 2. Functional Block Diagram



GT5315

5. Pin Configuration

5.1 SOT89-5 (Top View)

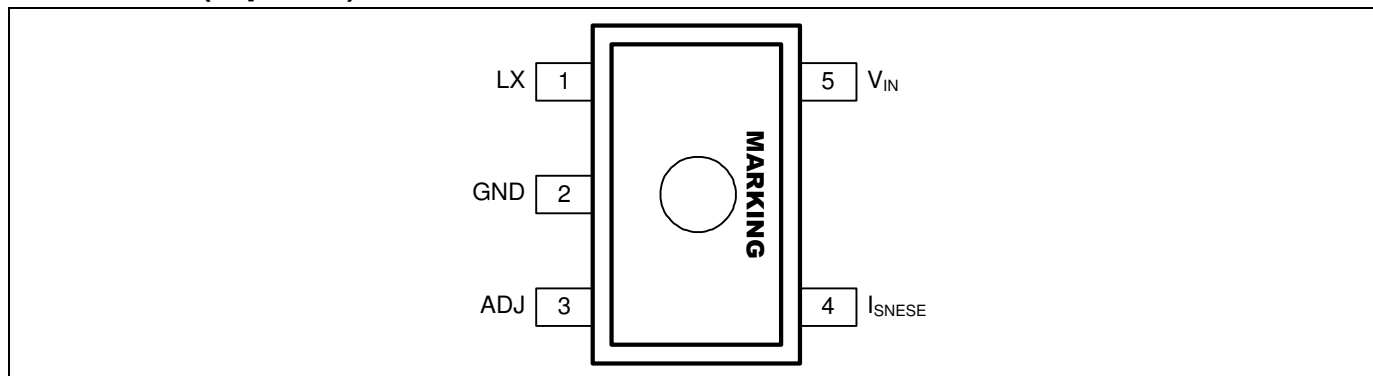

Figure 3. Pin Assignment Diagram (SOT89-5 Package)

Note: Please see section “Part Markings” for detailed Marking Information.

5.2 Pin Descriptions

Pin No.	Name	I/O	Function
1	LX	O	Drain of NDMOS switch.
2	GND	-	Ground (0V)
3	ADJ	I/O	Multi-function On/Off and brightness control pin: <ul style="list-style-type: none"> Leave floating for normal operation. ($V_{ADJ} = V_{REF} = 2.5V$ giving nominal average output current $I_{OUTnom} = 0.1/R_S$) Drive to voltage below 0.2V to turn off output current Drive with DC voltage ($0.3V < V_{ADJ} < 2.5V$) to adjust output current from 12% to 100% of I_{OUTnom} Connect a capacitor from this pin to ground to set soft-start time. Soft start time increases approximately 0.25ms/nF
4	ISENSE	I	Connect resistor R_S from this pin to V_{IN} to define nominal average output current $I_{OUTnom} = 0.1/R_S$ (Note: $R_{SMIN} = 0.1\Omega$ with ADJ pin open-circuit; R_S must be close to V_{IN} and I_{SENSE} pin.)
5	V_{IN}	-	Input voltage (6V to 40V). Decouple to ground with 4.7 μ F or higher X7R ceramic capacitor close to device



GT5315

6. Functional Description

The device, in conjunction with the coil (L1) and current sense resistor (RS), forms a self oscillating continuous-mode buck converter.

6.1 Device operation (Refer to **Figure 2. Functional Block Diagram** and **Figure 4 Operating waveforms**)

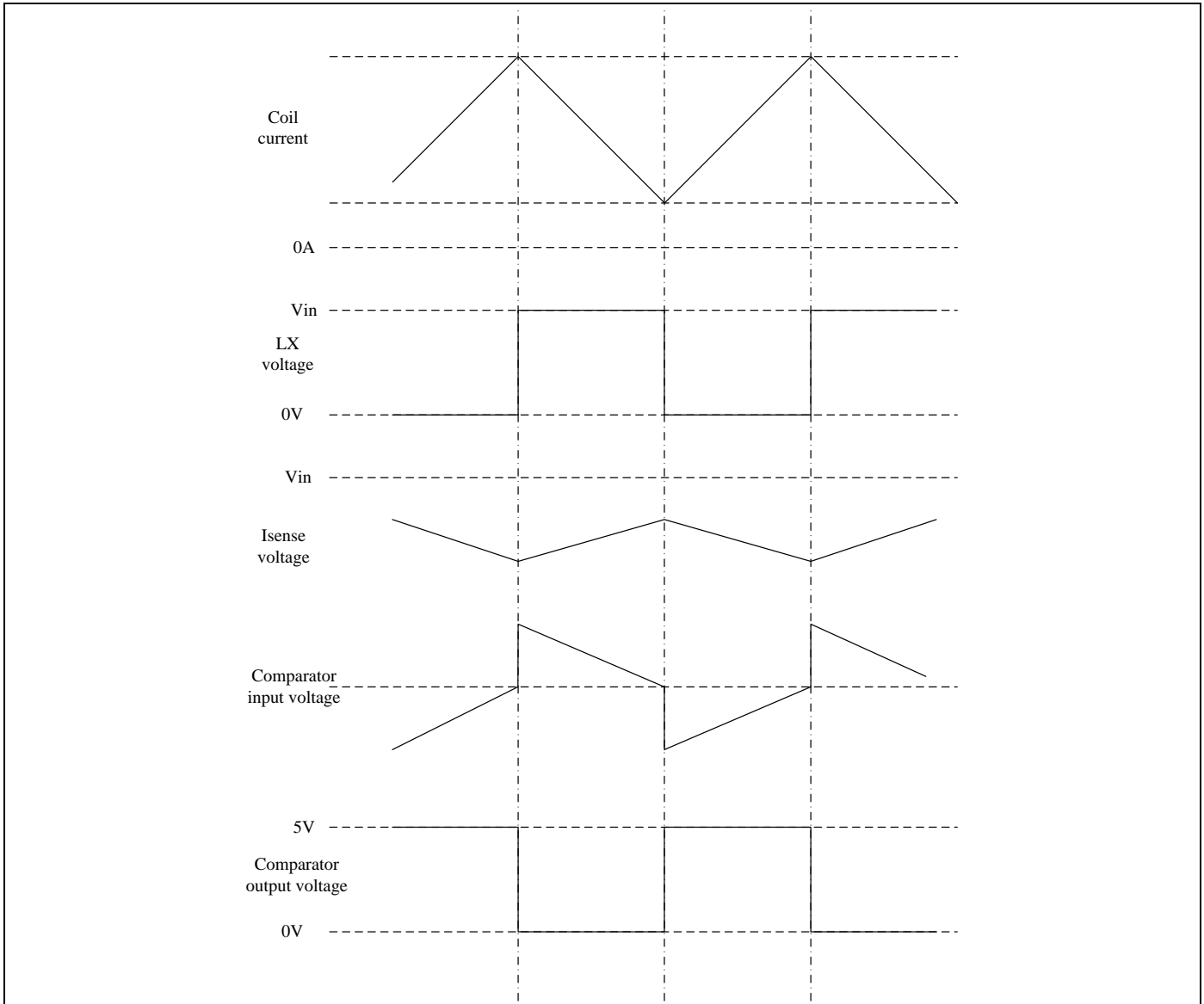

Figure 4. Operating waveforms

Operation can be best understood by assuming that the ADJ pin of the device is unconnected and the voltage on this pin (V_{ADJ}) appears directly at the (+) input of the comparator.

When input voltage V_{IN} is first applied, the initial current in L1 and RS is zero and there is no output from the current sense circuit. Under this condition, the (-) input to the comparator is at ground and its output is high. This turns MN on and switches the LX pin low, causing current to flow from V_{IN} to ground, via R_S , L1 and the LED(s). The current rises at a rate determined by V_{IN} and L1 to produce a voltage ramp (V_{SENSE}) across RS. The supply referred voltage V_{SENSE} is forced across internal resistor R1 by the



GT5315

current sense circuit and produces a proportional current in internal resistors R2 and R3. This produces a ground referred rising voltage at the (-) input of the comparator. When this reaches the threshold voltage (V_{REF}), the comparator output switches low and MN turns off. The comparator output also drives another NMOS switch, which bypasses internal resistor R3 to provide a controlled amount of hysteresis. The hysteresis is set by R3 to be nominally 5% of V_{ADJ} at $V_{IN}=24V$.

When MN is off, the current in L1 continues to flow via D1 and the LED(s) back to V_{IN} . The current decays at a rate determined by the LED(s) and diode forward voltages to produce a falling voltage at the input of the comparator. When this voltage returns to V_{REF} , the comparator output switches high again. This cycle of events repeats, with the comparator input ramping between limits of $V_{REF} \pm 5\%$ at $V_{IN}=24V$.

6.2 Switching thresholds

With $V_{ADJ} > V_{REF}$, the ratios of R1, R2 and R3 define an average V_{SENSE} switching threshold of 100mV (measured on the I_{SENSE} pin with respect to V_{IN}). The average output current I_{OUTnom} is then defined by this voltage and R_S according to:

$$I_{OUTnom} = 100mV/R_S$$

Nominal ripple current is $\pm 5mV/R_S$ at $V_{IN}=24V$

6.3 Adjusting output current

The device contains a low pass filter between the ADJ pin and the threshold comparator and an internal current limiting resistor (500k Ω nom) between ADJ and the internal reference voltage. This allows the ADJ pin to be overdriven with either DC or pulse signals to change the V_{SENSE} switching threshold and adjust the output current.

Details of the different modes of adjusting output current are given in the applications section.

6.4 Output shutdown

The output of the low pass filter drives the shutdown circuit. When the input voltage to this circuit falls below the threshold (0.2V nom.), the output switch are turned off.

The voltage reference remains powered during shutdown to provide the bias current for the shutdown circuit. Quiescent supply current during shutdown is nominally 120 μA and switch leakage is below 5 μA .



GT5315

6.5 Application notes

Setting nominal average output current with external resistor R_S

The nominal average output current in the LED(s) is determined by the value of the external current sense resistor (R_S) connected between VIN and ISENSE and is given by:

$$I_{OUTnom} = 0.1/R_S \text{ [for } R_S \geq 0.1\Omega \text{]}$$

The table below gives values of nominal average output current for several preferred values of current setting resistor (R_S) in the typical application circuit:

R_S ()	Nominal Average Output Current(mA)
0.1	1000
0.13	760
0.15	667

The above values assume that the ADJ pin is floating and at a nominal voltage of internal power supply (=5V).

Note: $R_S = 0.1\Omega$ is the minimum allowed value of sense resistor under these conditions to maintain switch current below the specified maximum value.

It is possible to use different values of R_S if the ADJ pin is driven from an external voltage. (See next section).

Output current adjustment by external DC control voltage

The ADJ pin can be driven by an external dc voltage (V_{ADJ}), as shown, to adjust the output current to a value above or below the nominal average value defined by R_S .

The nominal average output current in this case is given by:

$$I_{OUTdc} = (V_{ADJ} / 2.5) \times 100mV \times R_S \text{ [for } 0.3 < V_{ADJ} < 2.5V \text{]}$$

Note: 100% brightness setting corresponds to $V_{ADJ} = V_{REF}$. When driving the ADJ pin above 2.5V, I_{OUTdc} will not change with ADJ pin voltage.

The input impedance of the ADJ pin is $500k\Omega \pm 25\%$.



GT5315

6.6 Output current adjustment by PWM control

Directly driving ADJ input

A Pulse Width Modulated (PWM) signal with duty cycle DPWM can be applied to the ADJ pin, as shown below, to adjust the output current to a value below the nominal average value set by resistor R_S :

Driving the ADJ input via open collector transistor

The recommended method of driving the ADJ pin and controlling the amplitude of the PWM waveform is to use a small NPN switching transistor as shown below:

This scheme uses the 500k Ω resistor between the ADJ pin and the internal voltage reference as a pull-up resistor for the external transistor.

Driving the ADJ input from a microcontroller

Another possibility is to drive the device from the open drain output of a microcontroller. The diagram below shows one method of doing this:

If the NMOS transistor within the microcontroller has high Drain / Source capacitance, this arrangement can inject a negative spike into ADJ input of the GT5315 and cause erratic operation but the addition of a Schottky clamp diode (cathode to ADJ) to ground and inclusion of a series resistor (3.3k Ω) will prevent this. See the section on PWM dimming for more details of the various modes of control using high frequency and low frequency PWM signals.

Shutdown mode

Taking the ADJ pin to a voltage below 0.2V for more than approximately 100 μ s, will turn off the output and supply current will fall to a low standby level of 120 μ A nominal.

Note: the ADJ pin is not a logic input. Taking the ADJ pin to a voltage above internal 5V power voltage will be harmful to the chip. (See graphs for details).

Soft-start

An external capacitor from the ADJ pin to ground will provide a soft-start delay, by increasing the time taken for the voltage on this pin to rise to the turn-on threshold and by slowing down the rate of rise of the control voltage at the input of the comparator. Adding capacitance increases this delay by approximately 0.25ms/nF.



GT5315

6.7 VIN capacitor selection

A low ESR capacitor should be used for input decoupling, as the ESR of this capacitor appears in series with the supply source impedance and lowers overall efficiency. This capacitor has to supply the relatively high peak current to the coil and smooth the current ripple on the input supply.

To avoid transients into the IC, the size of the input capacitor will depend on the V_{IN} voltage:

$$V_{IN} = 6V \text{ to } 40V \quad C_{IN} = 2.2\mu F$$

When the input voltage is close to the output voltage the input current increases which puts more demand on the input capacitor. The minimum value of $2.2\mu F$ may need to be increased to $4.7\mu F$; higher values will improve performance at lower input voltages, especially when the source impedance is high. The input capacitor should be placed as close as possible to the IC.

For maximum stability over temperature and voltage, capacitors with X7R, X5R, or better dielectric is recommended. Capacitors with Y5V dielectric are not suitable for decoupling in this application and should **NOT** be used.

If higher voltages are used and the C_{IN} is $10\mu F$. This can be an electrolytic capacitor provide a suitable $1\mu F$ ceramic capacitor is also used and positioned as close the V_{IN} of the IC as possible.

A suitable TDK capacitor would be CK657NX7R2AXXM.

The following web sites are useful when finding alternatives:

www.tdk.com

www.murata.com

www.t-yuden.com

www.kemet.com

www.avxcorp.com



GT5315

6.8 Inductor selection

Recommended inductor values for the GT5315 are in the range 68 μ H to 220 μ H. Higher values of inductance are recommended at higher supply voltages in order to minimize errors due to switching delays, which result in increased ripple and lower efficiency. Higher values of inductance also result in a smaller change in output current over the supply voltage range. (See graphs). The inductor should be mounted as close to the device as possible with low resistance connections to the LX and V_{IN} pins.

The chosen coil should have a saturation current higher than the peak output current and a continuous current rating above the required mean output current.

Suitable coils for use with the GT5315 may be selected from the MSS range manufactured by Coil craft, or the NPIS range manufactured by NIC components.

The inductor value should be chosen to maintain operating duty cycle and switch 'on'/'off' times within the specified limits over the supply voltage and load current range.

Note: in practice, the duty cycle and operating frequency will deviate from the calculated values due to dynamic switching delays, switch rise/fall times and losses in the external components.

Optimum performance will be achieved by setting the duty cycle close to 0.5 at the nominal supply voltage. This helps to equalize the undershoot and overshoot and improves temperature stability of the output current.



GT5315

6.9 Diode selection

For maximum efficiency and performance, the rectifier (D1) should be a fast low capacitance Schottky diode with low reverse leakage at the maximum operating voltage and temperature.

They also provide better efficiency than silicon diodes, due to a combination of lower forward voltage and reduced recovery time. It is important to select parts with a peak current rating above the peak coil current and a continuous current rating higher than the maximum output load current. It is very important to consider the reverse leakage of the diode when operating above +125°C. Excess leakage will increase the power dissipation in the device and if close to the load may create a thermal runaway condition. The higher forward voltage and overshoot due to reverse recovery time in silicon diodes will increase the peak voltage on the LX output. If a silicon diode is used, care should be taken to ensure that the total voltage appearing on the LX pin including supply ripple, does not exceed the specified maximum value.



GT5315

6.10 Reducing output ripple

Peak to peak ripple current in the LED(s) can be reduced, if required, by shunting a capacitor C_{led} across the LED(s) as shown below:

A value of $1\mu\text{F}$ will reduce the supply ripple current by a factor three (approx.). Proportionally lower ripple can be achieved with higher capacitor values. Note that the capacitor will not affect operating frequency or efficiency, but it will increase start-up delay, by reducing the rate of rise of LED voltage.

By adding this capacitor the current waveform through the LED(s) changes from a triangular ramp to a more sinusoidal version without altering the mean current value.

Operation at low supply voltage

Below the under-voltage lockout threshold (V_{SD}) the drive to the output transistor is turned off to prevent device operation with excessive on-resistance of the output transistor. The output transistor is not full enhanced until the supply voltage exceeds approximately 6V. At supply voltages between V_{SD} and 6V care must be taken to avoid excessive power dissipation due to the on-resistance.

Note: when driving loads of two or more LEDs, the forward drop will normally be sufficient to prevent the device from switching below approximately 5V. This will minimize the risk of damage to the device.

Thermal considerations

When operating the device at high ambient temperatures, or when driving maximum load current, care must be taken to avoid exceeding the package power dissipation limits. The graph below gives details for power derating. This assumes the device to be mounted on a 25mm^2 PCB with 1oz copper standing in still air.

Note: the device power dissipation will most often be a maximum at minimum supply voltage. It will also increase if the efficiency of the circuit is low. This may result from the use of unsuitable coils, or excessive parasitic output capacitance on the switch output.

Thermal compensation of output current

High luminance LEDs often need to be supplied with a temperature compensated current in order to maintain stable and reliable operation at all drive levels. The LEDs are usually mounted remotely from the device so, for this reason, the temperature coefficients of the internal circuits for the GT5315 have been optimized to minimize the change in output current when no compensation is employed. If output current compensation is required, it is possible to use an external temperature sensing network - normally using Negative Temperature Coefficient (NTC) thermistors and/or diodes, mounted very close to the LED(s). The output of the sensing network can be used to drive the ADJ pin in order to reduce output current with increasing temperature.



GT5315

6.11 Layout considerations

LX pin

The LX pin of the device is a fast switching node, so PCB tracks should be kept as short as possible. To minimize ground 'bounce', the ground pin of the device should be soldered directly to the ground plane.

Coil and decoupling capacitors and current sense resistor

It is particularly important to mount the coil and the input decoupling capacitor as close to the device pins as possible to minimize parasitic resistance and inductance, which will degrade efficiency. It is also important to minimize any track resistance in series with current sense resistor R_S . Its best to connect V_{IN} directly to one end of R_S and I_{SENSE} directly to the opposite end of R_S with no other currents flowing in these tracks, or **system may not be working in the right way**. It is important that the cathode current of the Schottky diode does not flow in a track between R_S and V_{IN} as this may give an apparent higher measure of current than is actual because of track resistance.

ADJ pin

The ADJ pin is a high impedance input so, when left floating, PCB tracks to this pin should be as short as possible to reduce noise pickup. A 100nF capacitor from the ADJ pin to ground will reduce frequency modulation of the output under these conditions. An additional series 3.3k Ω resistor can also be used when driving the ADJ pin from an external circuit (see below). This resistor will provide filtering for low frequency noise and provide protection against high voltage transients.

High voltage tracks

Avoid running any high voltage tracks close to the ADJ pin, to reduce the risk of leakage currents due to board contamination. A ground ring placed around the ADJ pin is recommended to minimize changes in output current under these conditions.

Evaluation PCB

GT5315 evaluation boards are available on request. These boards contain LEDs to allow quick testing of the GT5315 device. Additional terminals allow for interfacing to customers own LED products.



GT5315

6.12 Dimming output current using PWM

Low frequency PWM mode

When the ADJ pin is driven with a low frequency PWM signal (eg 100Hz), with a high level voltage V_{ADJ} and a low level of zero, the output of the internal low pass filter will swing between 0V and V_{ADJ} , causing the input to the shutdown circuit to fall below its turn-off threshold (200mV nom) when the ADJ pin is low. This will cause the output current to be switched on and off at the PWM frequency, resulting in an average output current I_{OUTavg} proportional to the PWM duty cycle.

The average value of output current in this mode is given by:

$$I_{OUTavg} = 0.1 * D_{PWM} / R_s \text{ [for } D_{PWM} > 0.001\text{]}$$

This mode is preferable if optimum LED 'whiteness' is required. It will also provide the widest possible dimming range (approx. 1000:1) and higher efficiency at the expense of greater output ripple.



GT5315

7. Electrical Characteristics

7.1 Absolute Maximum Ratings

Condition	Min	Max
Supply Voltage (V_{IN})	-0.3V	40V
Operating Temperature	-40°C	125°C
Storage Temperature	-55°C	150°C
Lead Temperature	-	300°C

Note: Stress greater than those listed under Absolute Maximum Ratings may cause permanent damage to the device. This is a stress rating only and functional operation of the device at these or any other conditions outside those indicated in the operational sections of this specification are not implied. Exposure to absolute maximum rating conditions for extended periods may affect reliability.

7.2 Operating Ratings

V_{IN}	6V to 40V
Thermal Resistance θ_{JA} SOT89-5 Package	110°C /W



GT5315

7.3 Electrical Characteristics

$V_{IN}=24V$ unless otherwise specified, $T_A=25^{\circ}C$ unless otherwise specified.

Symbol	Parameter	Conditions	Min.	Typ.	Max.	Unit
V_{IN}	Input Voltage		6	-	40	V
V_{UVLO}	Under voltage lock out	V_{IN} falling	-	5.4	-	V
$V_{UVLO, HYS}$	UVLO hysteresis	V_{IN} rising	-	300	-	mV
FSW Max	Switching Frequency		-	2	-	MHz
Current Sense						
V_{CSN}	Mean current sense threshold voltage	$V_{IN}-V_{CSN}$	95	106	115	mV
$V_{CSN, hys}$	Sense threshold hysteresis		-	± 5	-	%
I_{CSN}	CSN Pin Input Current	$V_{IN}-V_{CSN}=50mV$	-	14	-	μA
Operating Current						
I_{OFF}	Quiescent supply current with output off	$V_{ADJ}<0.2V$	-	120	-	μA
DIM Input						
V_{ADJ}	V_{ADJ} Internal supply	Voltage ADJ floating	-	5	-	V
$V_{ADJ, H}$	DIM Input voltage High		2.5	-	-	V
$V_{ADJ, L}$	Input Voltage Low		-	0.2	0.3	V
$V_{ADJ, DC}$	DC Brightness Control		0.3		2.5	V
$f_{ADJ, Max.}$	ADJ Frequency	$f_{OSC}=500kHz$	-	-	50	kHz
$D_{PWM, LF}$	Duty cycle range of low frequency dimming	$f_{DIM}=100Hz$	-	-	1	
	Brightness control range			5000:1		
$D_{PWM, LF}$	Duty cycle range of low frequency dimming	$f_{ADJ}=20kHz$	-	-	1	
	Brightness control range		-	25:1	-	
R_{ADJ}	ADJ pull up resistor to Internal supply voltage		-	500	-	K Ω
$I_{ADJ, L}$	ADJ input leakage low	$V_{ADJ}=0$	-	10	-	μA
Output Switch						
R_{LX}	LX On Resistance		-	0.41	-	Ω
$I_{LX, mean}$	Continuous LX Current		-	-	1.2	A
I_{LEAK}	LX Leakage Current		-	0.5	5	μA
Thermal Shutdown						
T_{SD}	Thermal Shutdown Threshold		-	140	-	$^{\circ}C$
$T_{SD, hys}$	Thermal Shutdown hysteresis		-	40	-	$^{\circ}C$



GT5315

7.4 TYPICAL PERFORMANCE CHARACTERISTICS

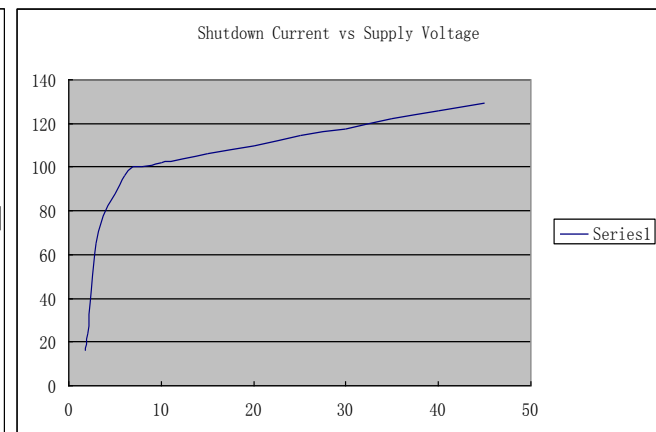
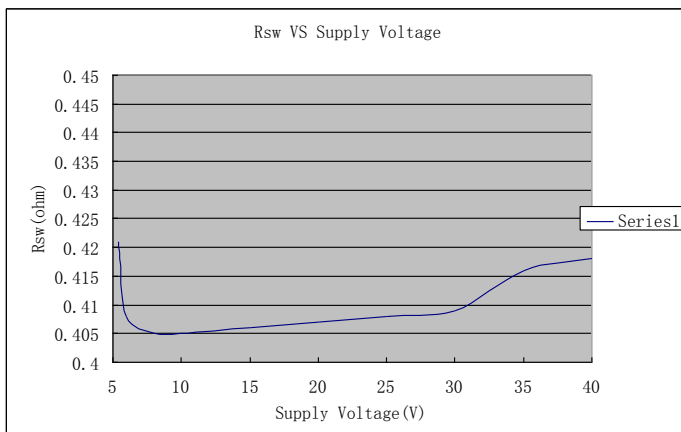
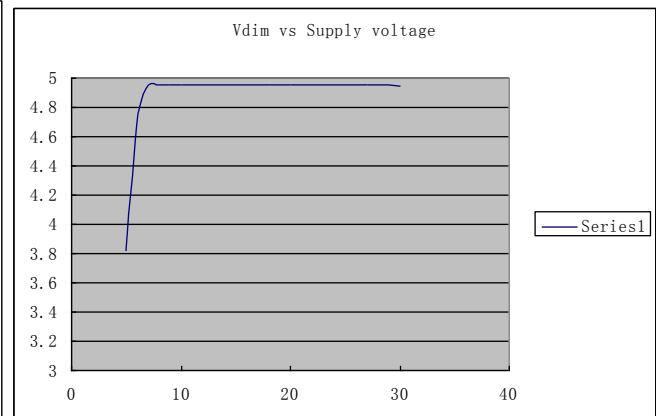
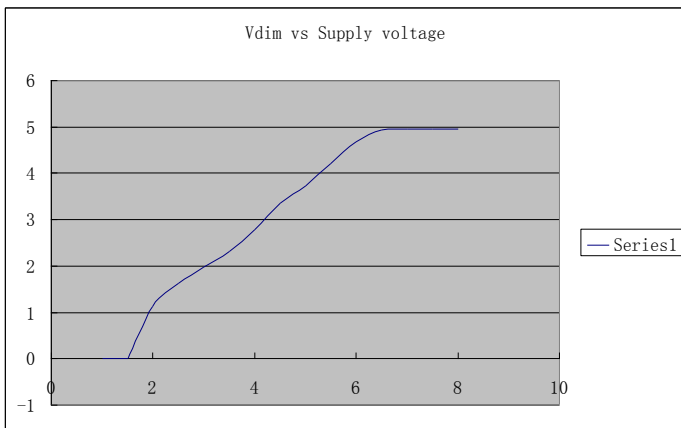
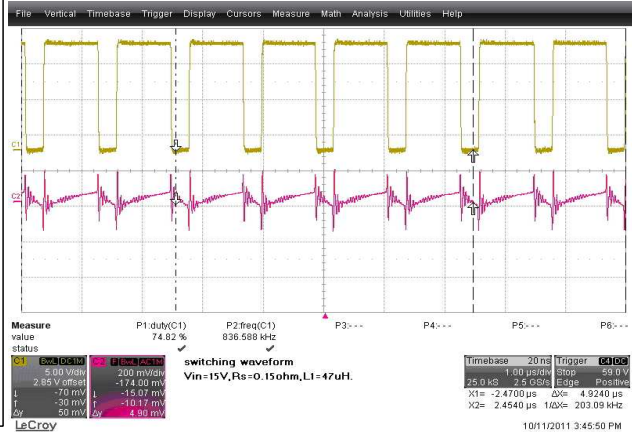
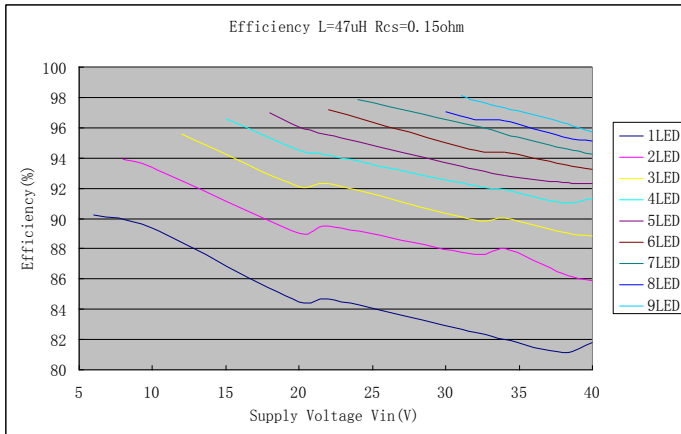



GT5315

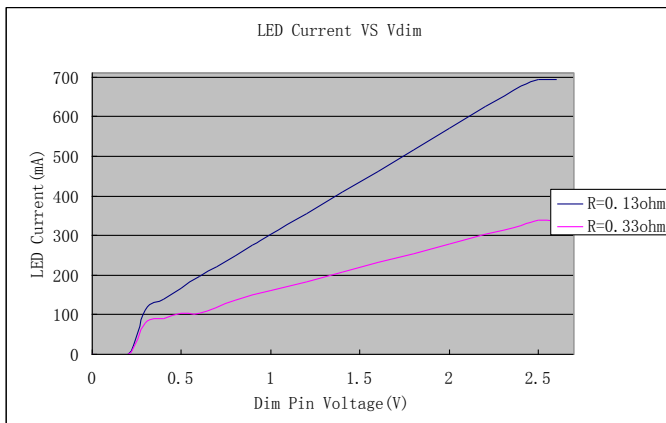
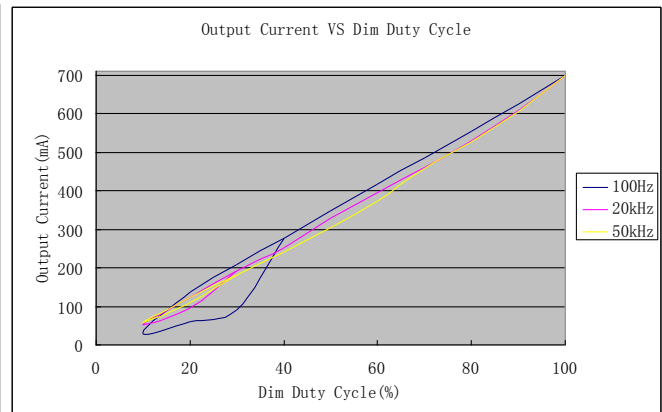
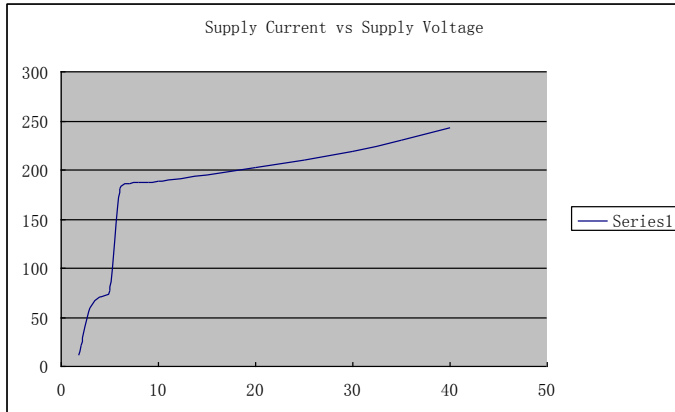



GT5315

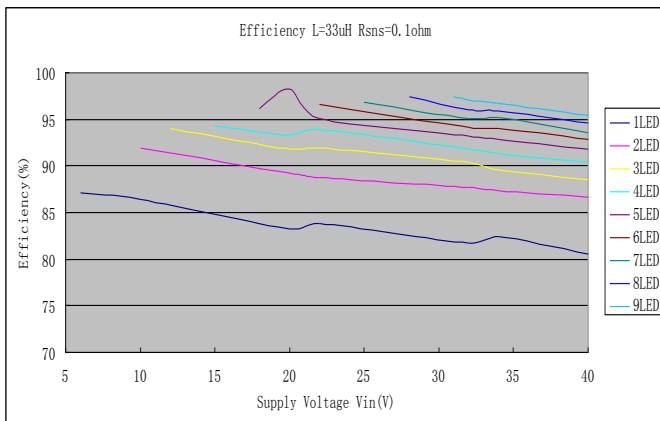
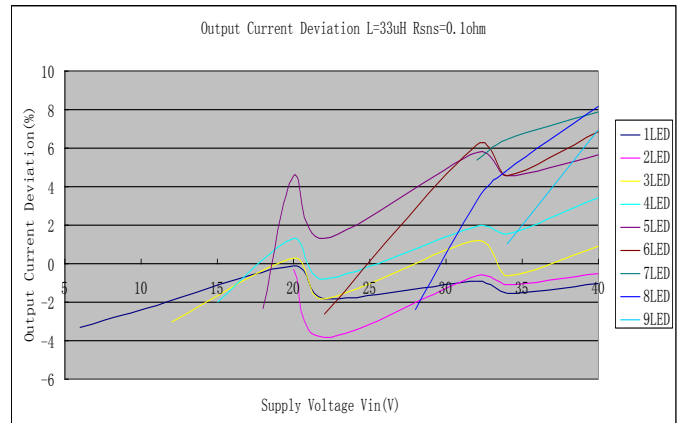
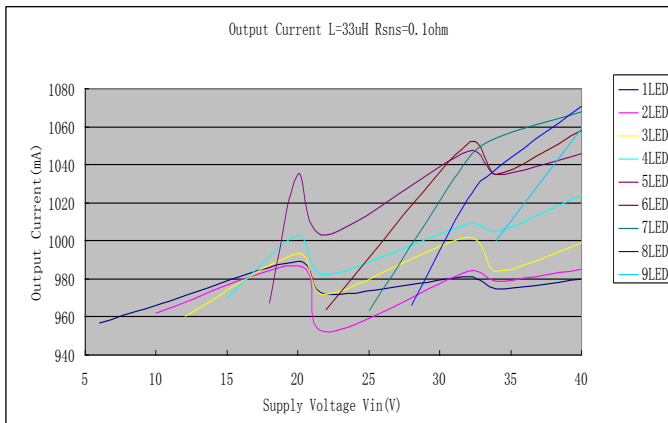
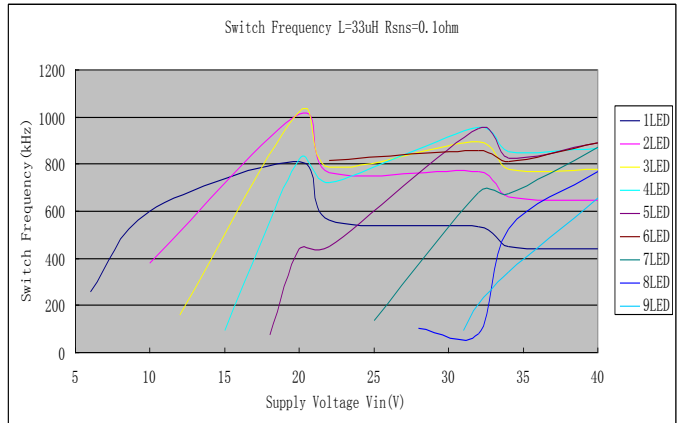
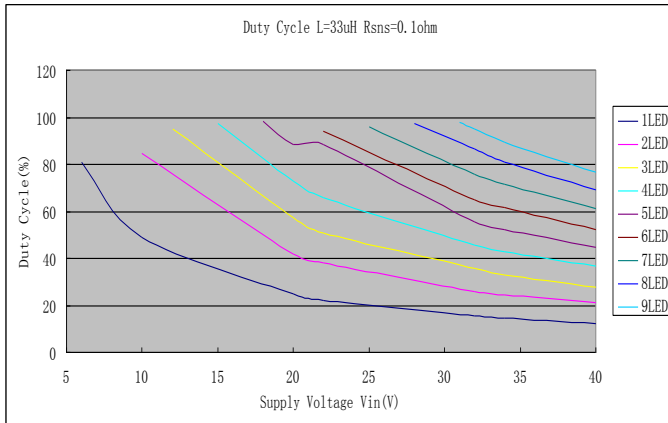



GT5315

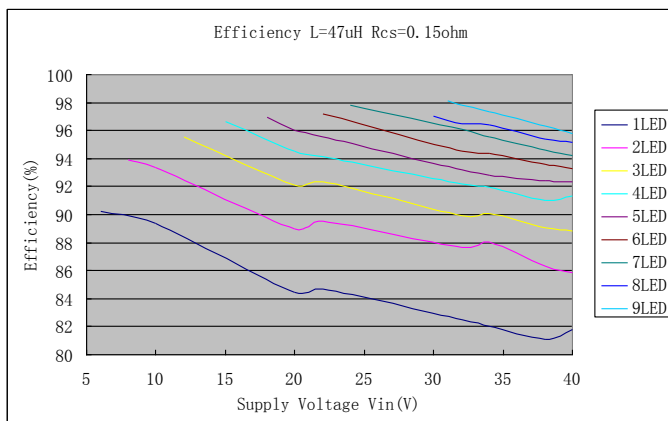
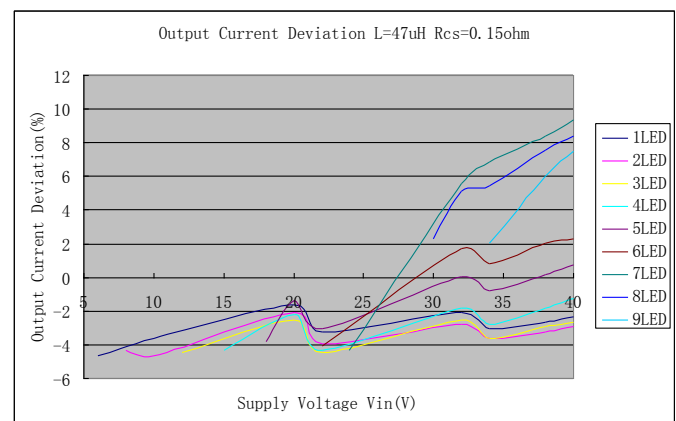
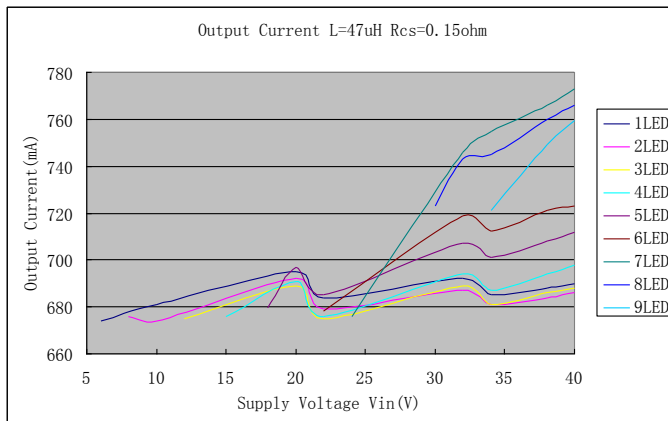
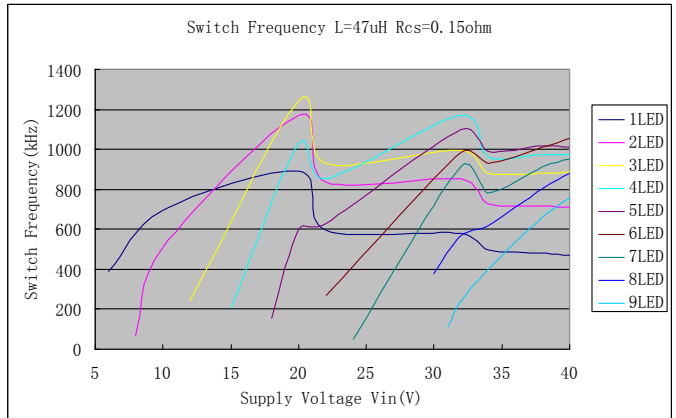
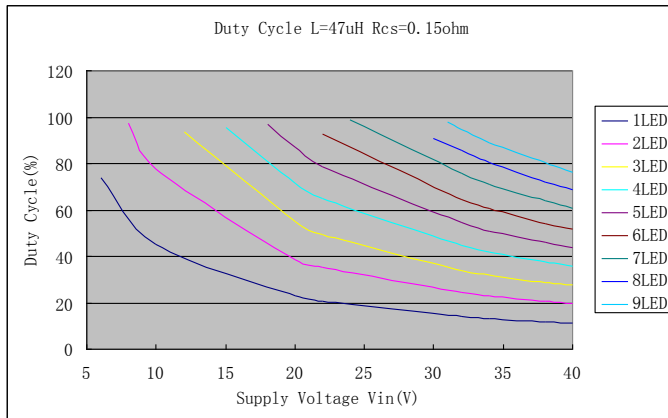



GT5315

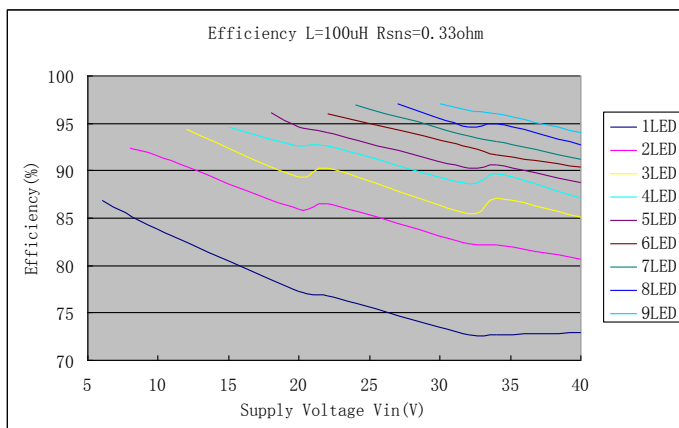
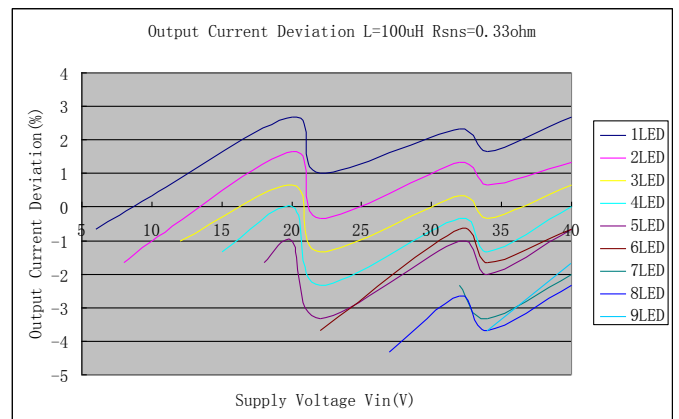
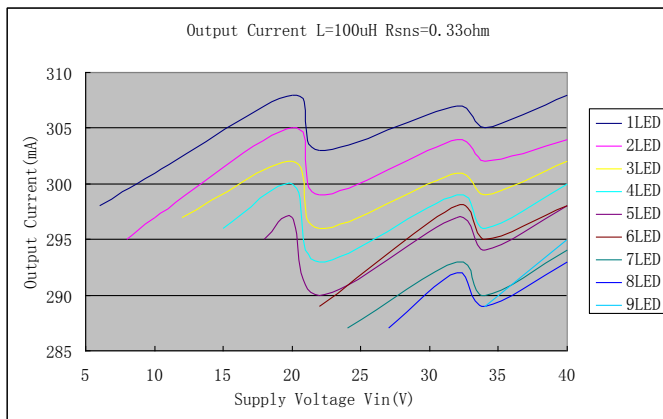
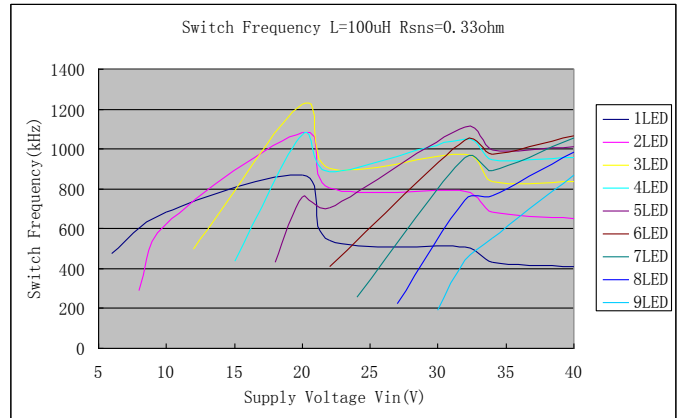
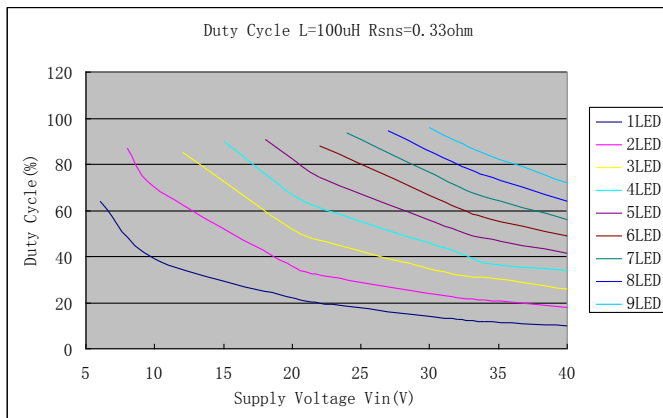



GT5315

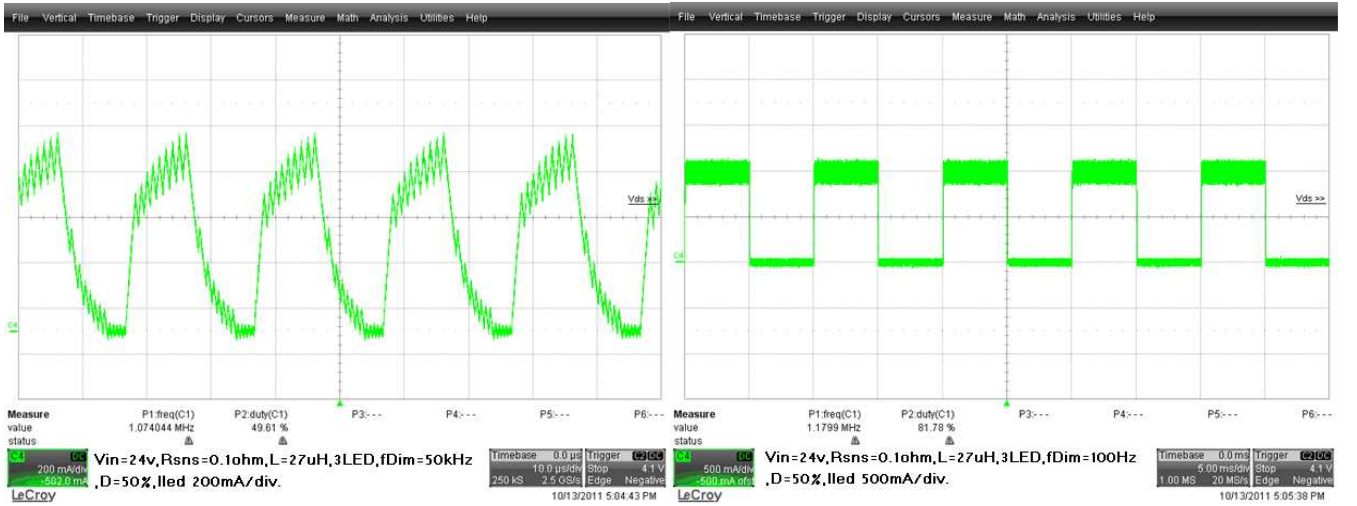
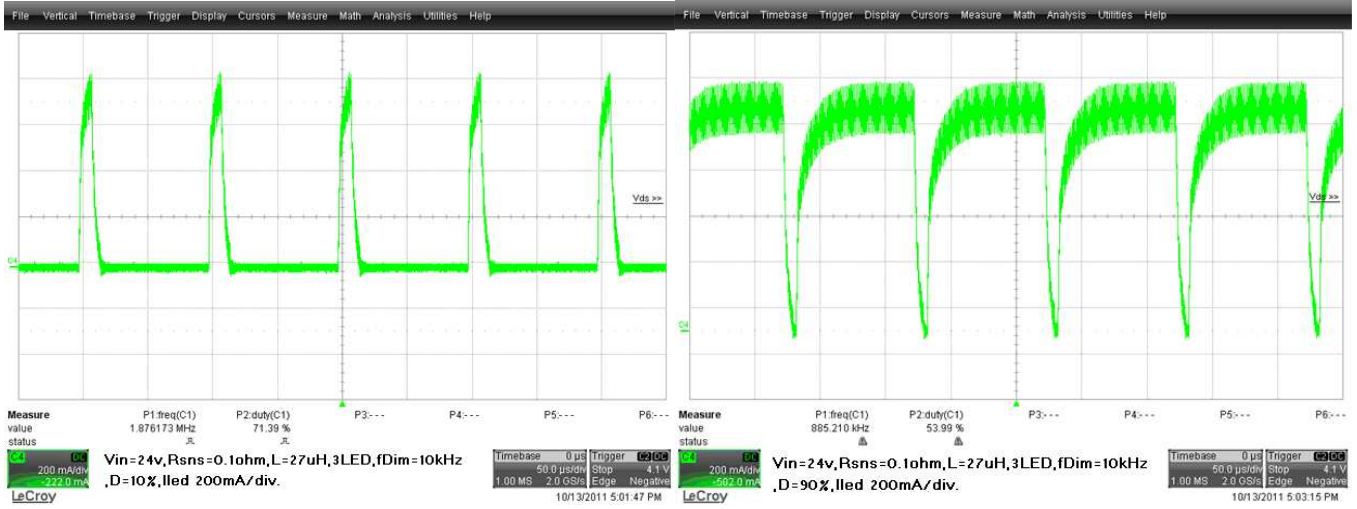



GT5315

8. Ordering Information

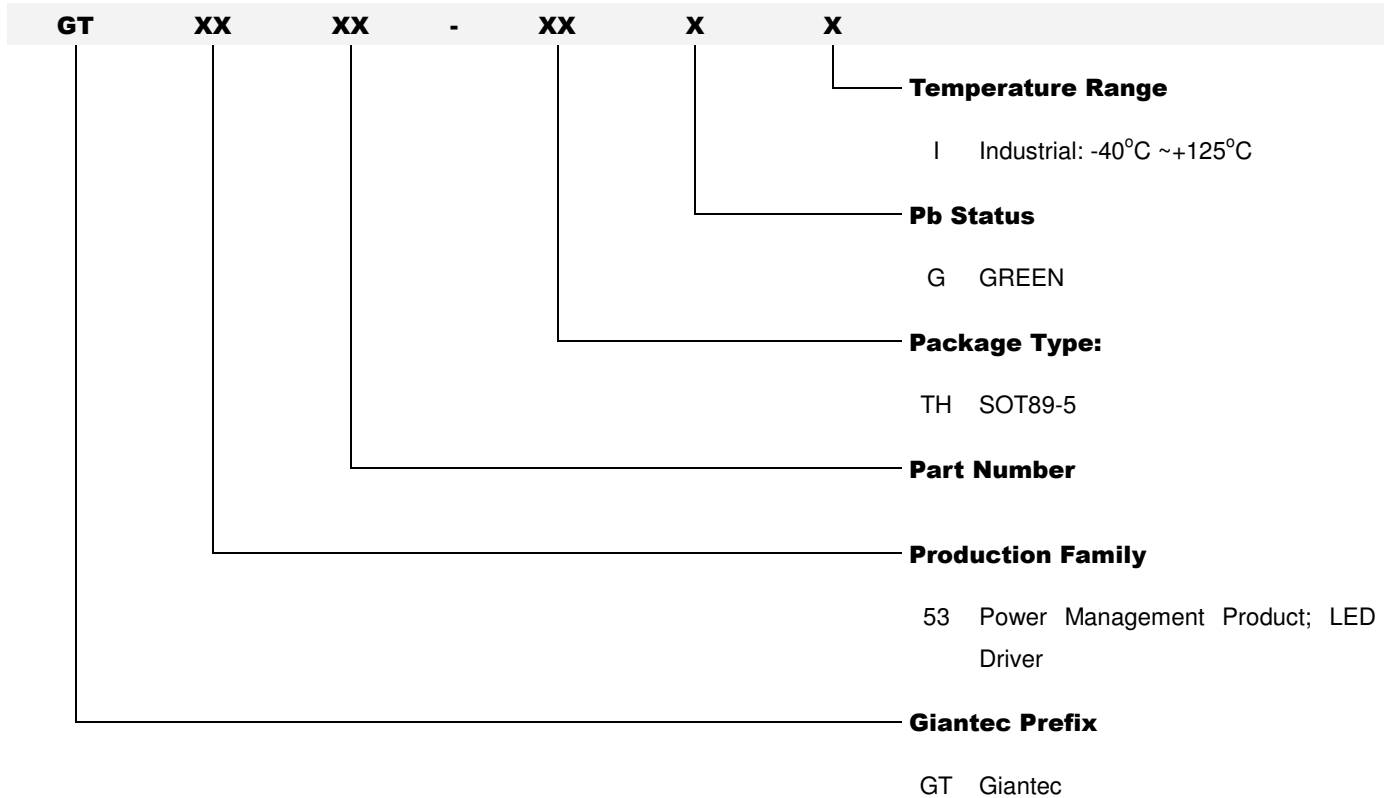

Order Number	Package Description	Package Option
GT5315-THGI	SOT89-5	Tape and Reel 3000



GT5315

9. Part Markings

9.1 GT5315-THGI (Top View)

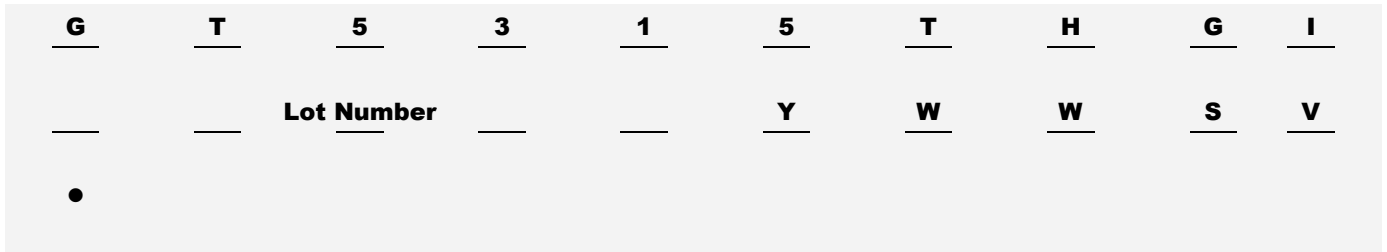

GT5315THGI

Lot Number	States the last 5 characters of the wafer lot information
•	Pin 1 Indicator
Y	Seal Year
	0 = 2010
	1 = 2011
	9 = 2019
WW	Seal Week
	01 = Week 1
	02 = Week 2
	.
	.
	.
	51 = Week 51
	52 = Week 52
S	Subcon Code
	J = ASESH
	L = ASEKS
V	Die Version



GT5315

10. Package Information

10.1 SOT89-5

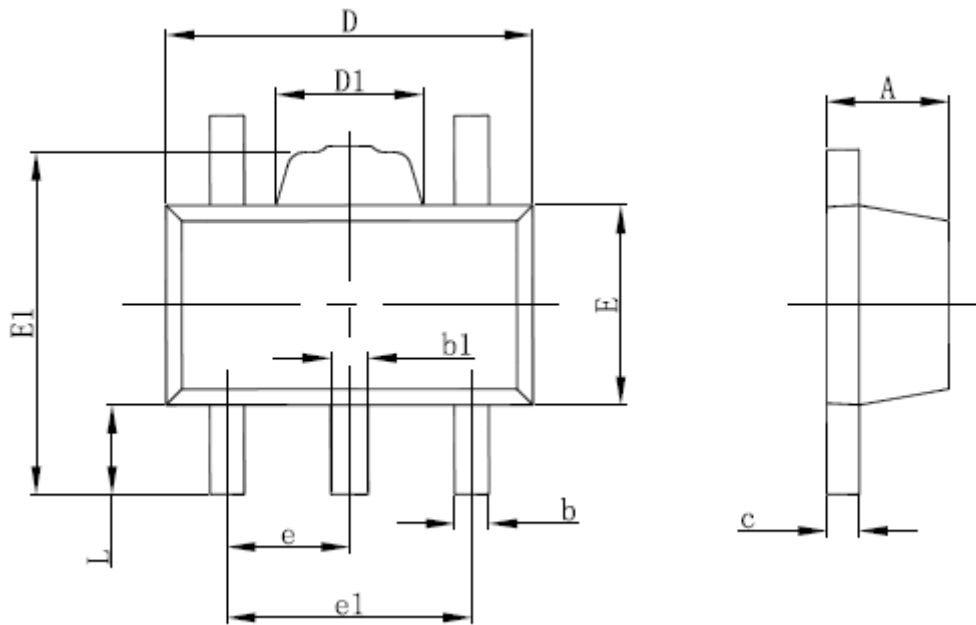

Symbol	Dimensions In Millimeters		Dimensions In Inches	
	Min.	Max.	Min.	Max.
A	1.400	1.600	0.055	0.063
b	0.320	0.520	0.013	0.020
b1	0.360	0.560	0.014	0.022
c	0.350	0.440	0.014	0.017
D	4.400	4.600	0.173	0.181
D1	1.400	1.800	0.055	0.071
E	2.300	2.600	0.091	0.102
E1	3.940	4.250	0.155	0.167
e	1.500TYP.		0.060TYP.	
e1	2.900	3.100	0.114	0.122
L	0.900	1.100	0.035	0.043



GT5315

11. Revision History

Revision	Date	Descriptions
A0	Nov., 2011	Initial Version