



# GT5152

## 2A, Synchronous Step-Down DC-DC Converter

**Advanced**

### 1. Features

- High Efficiency: Up to 95%
- Up to 2A Output Current
- Very Low Shutdown Current: 20 $\mu$ A(Max.) at Input 12V Supply Voltage
- Integrated 0.18 $\Omega$  Switch
- Operating Switching Frequency Fixed 350kHz
- 4.75V to 24V Input Voltage Range
- Support 28V Switching and Below 32V Glitch
- Programmable Output Voltage from 0.9V to 21V.
- Current Mode Operation with External Compensation for Optimized Loop Bandwidth
- Over Temperature Shutdown
- Cycle-by-Cycle Over Current Protection
- Programmable Soft Start
- Input Under Voltage Lockout
- Operating Temperature: -40 $^{\circ}$ C to +85 $^{\circ}$ C
- Package Available: 8-Pin SOP Package and HSOP

### 2. General Description

The GT5152 device is a high efficiency monolithic synchronous step-down bulk regulator using current mode architecture with two integrated power MOSFETs. This device delivers up to 2A of output current over a wide operating voltage supply range from 4.75V to 24V which makes this device ideally suited for many applications such as battery powered systems, distributed power systems, networking systems and green electronics/appliances. Current mode operation provides fast transient response

and excellent load and line regulation. The switching frequency of GT5152 is fixed 350kHz.

The fault condition protections such as cycle-by-cycle current limiting and over temperature hysteretic shutdown are implemented. In shutdown mode the converter draws 20 $\mu$ A of supply current at the maximum input supply voltage. Additional features include adjustable start, and enable. The GT5152 is available in an 8-Pin SOP package and thermal enhanced HSOP package.

### 3. Applications

- Networking systems
- Battery Powered Systems
- Distributed Power Systems
- Pre-regulator for Linear Regulators

Copyright © 2012 Giantec Semiconductor Inc. (Giantec). All rights reserved. Giantec reserves the right to make changes to this specification and its products at any time without notice. Giantec products are not designed, intended, authorized or warranted for use as components in systems or equipment intended for critical medical or surgical equipment, aerospace or military, or other applications planned to support or sustain life. It is the customer's obligation to optimize the design in their own products for the best performance and optimization on the functionality and etc. Giantec assumes no liability arising out of the application or use of any information, products or services described herein. Customers are advised to obtain the latest version of this device specification before relying on any published information and prior placing orders for products.



# GT5152

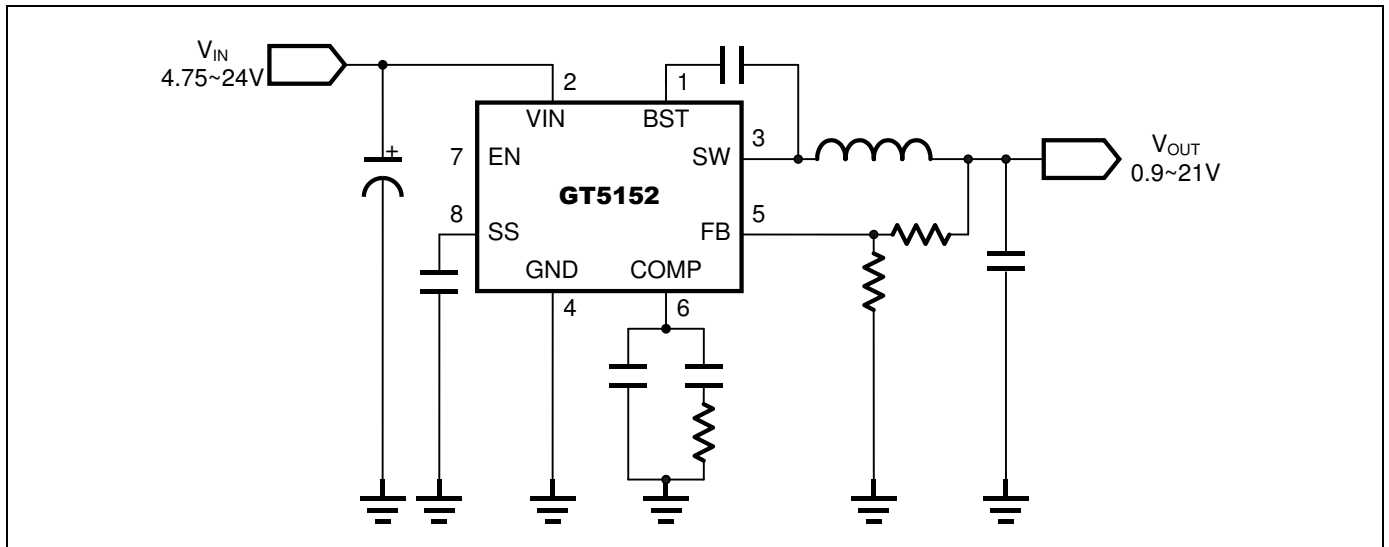

Figure 1. Typical Application Circuit



# GT5152

## 4. Functional Block Diagram

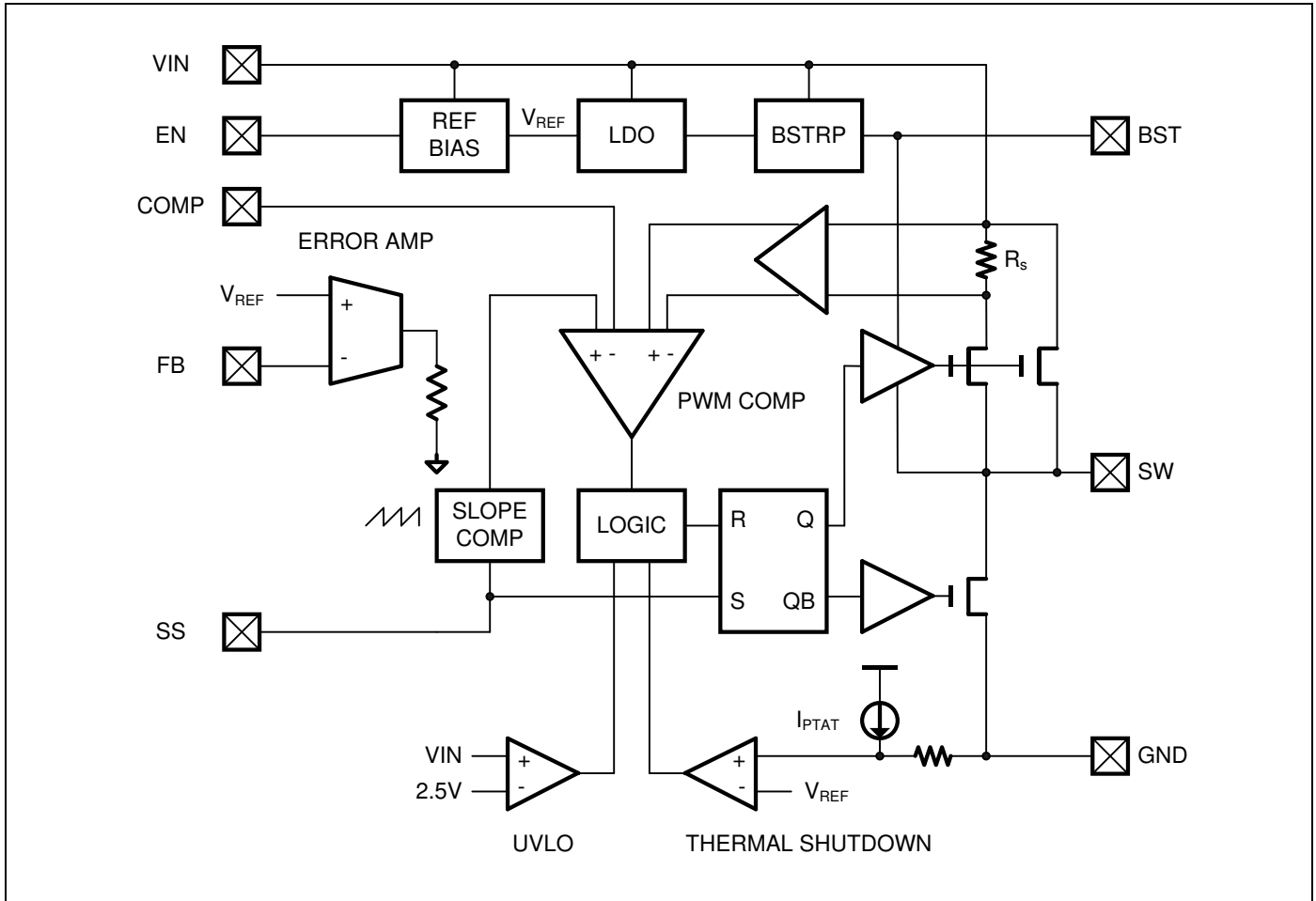

Figure 2. Current Mode Buck Converter



# GT5152

## 5. Pin Configuration

### 5.1 GT5152 SOP8 (Top View)

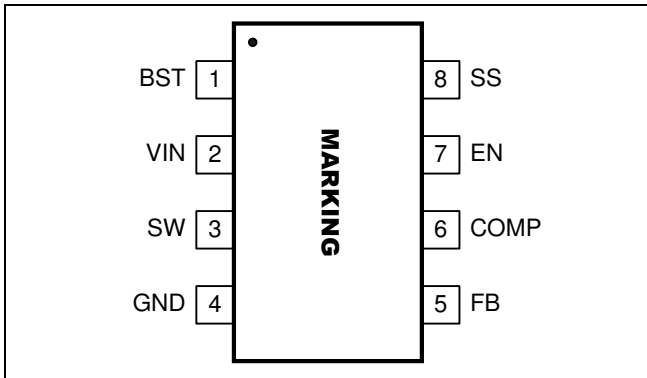

**Figure 3. Pin Assignment Diagram (SOP8 Package)**

### 5.2 GT5152 HSOP8 (Top View)

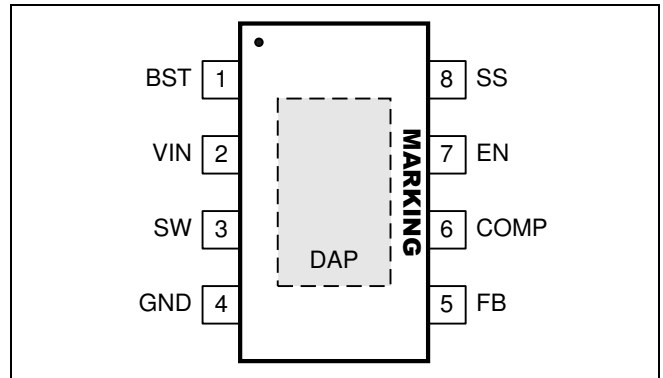

**Figure 4. Pin Assignment Diagram (HSOP8 Package)**

**Note:** Please see section “Part Markings” for detailed Marking Information.

### 5.3 Pin Descriptions

Pin No.	Name	I/O	Function
1	BST	I	A 2~10nF ceramic capacitor is connected from this pin to the SW pin to drive the power switch's gate above Bootstrap the power supply voltage.
2	VIN	-	Supply. Connect this pin to a supply voltage from 4.75V to 24V
3	SW	O	Switching node for the converter. Connect inductor to this node.
4	GND	-	Ground. This pin is the voltage reference for the regulated output voltage.
5	FB	I	Feedback. An external resistor divider sets the output voltage.
6	COMP	I	Compensation. Connect a compensation network to stable the loop and optimize the loop bandwidth.
7	EN	I	Enable. Pull down to ground to turn-off the converter. Leave EN open if it is unused or Pull-up.
8	SS	I	Soft-Start Control Input. SS controls the soft start period. Connect a capacitor from SS to GND to set the soft-start period. A 0.1μF capacitor sets the soft-start period to 15ms. To disable the soft-start feature, leave SS unconnected.



# GT5152

---

## 6. Functional Description

### 6.1 Operation

The GT5152 uses current mode PWM step-down architecture with internal top and bottom power switches. The switching frequency is fixed 350kHz.

The operating description is referring to functional bloc diagram (**Figure 1**). During normal operation, the rising edge of internal oscillator clock sets the RS latch and the top NMOS switch is turned on each switching cycle. The inductor current is sensed and amplified by current sense amplifier. Ramp compensation is summed to the error amplifier output and compare to the COMP pin voltage with PWM comparator. The output of PWM comparator resets the RS latch, turns off the top NMOS switch until next cycle and turn on the bottom NMOS switch. During the off-time of top NMOS switch, inductor current discharges through bottom MNOS switch, which ensures the bootstrap capacitor fully charged during DCM mode.

When voltage of FB pin exceeds 20% the normal regulation voltage of 0.9V, the over voltage comparator is tripped and turn off the high-side-switch.

### 6.2 Enable

Logic low EN forces the GT5152 into shut down mode. In shutdown, this device only draws 20 $\mu$ A supply current at

maximum supply voltage.

### 6.3 Short-Circuit Protection

The frequency of the oscillator is reduced to 1/4 of the normal frequency when the output is shorted to ground. This function ensures enough time for inductor current to decay.

### 6.4 Thermal Shutdown

The device goes into thermal shutdown mode when the junction temperature exceeds 150 $^{\circ}$ C. It continues normal operation when the temperature falls below 120 $^{\circ}$ C.

### 6.5 Boost Function

A 2~10nF capacitor  $C_{BOOST}$  is used to generate a voltage  $V_{BOOST}$  to drive the gate of top NMOS switch above the supply voltage. The voltage across this capacitor is about 5V.

### 6.6 Under Voltage Lockout

The under voltage lockout circuit prevents the device from miss operation at low-input voltages. It turns off the switches under undefined conditions. The minimum input voltage to start up the GT5152 is 4.5V and device will shut down at 3.5V.



# GT5152

## 7. Theory or operation/design procedure

### 7.1 Inductor Selection

There are two main considerations when selecting optimal inductors. First, the inductor should not saturate, and second, the inductor current ripple should be small enough to achieve the desired output voltage ripple. The dc resistance of the inductance directly influences the efficiency of the converter. Therefore, an inductor with lowest dc resistance should be selected for highest efficiency.

In order to avoid saturation of the inductor, the inductor should be rated at least for the maximum output current plus the inductor ripple current which is calculated as:

$$I_{PEAK} = I_{LOAD} + \frac{V_{OUT} \times (V_{IN} - V_{OUT})}{2L \times f \times V_{IN}} \quad (1)$$

Where

f= Switching frequency (350kHz typical)

L= Inductor value

**Table 1: Recommended Components for Standard Output Voltages**

Fs VOUT	1.5	1.8	2.5	3.3	5	12
default	6.8μH	10μH	10μH	15μH	22μH	33μH

### 7.2 Output Capacitor Selection

A 22μF (typical) output capacitor is needed with a 6.8μH inductor. Ceramic capacitors with low ESR are used for the lowest output voltage ripple.

The overall output ripple voltage is the sum of the voltage spike caused by the output ESR plus the voltage ripple caused by charge and discharging the output capacitor

$$V_{RIPPLE} = V_{OUT} \times \frac{1 - \frac{V_{OUT}}{V_{IN}}}{L \times f} \times \left( \frac{1}{8 \times C_{OUT} \times f} + R_{ESR} \right) \quad (2)$$

The largest output voltage ripple occurs at the highest input voltage.

### 7.3 Input Capacitor Selection

In continuous mode, the input current to the device is discontinuous, therefore a low ESR input capacitor is required for best input voltage filtering and minimizing the interference with other circuits caused by high input voltage spikes. This capacitor should have a minimum value of 10μF.

Since it absorbs the input switching current it requires an adequate ripple current rating. Its RMS current rating should be greater than approximately 1/2 of the output current.

For insuring stable operation the capacitor should be placed as close to the IC possible.

### 7.5 Feedback divider resistors to set output voltage - R2, R1

The output voltage is set by R2 and R1,  $V_{OUT} = 0.9 \times (1 + R_2 / R_1)$ . 10kΩ is a good typical value, and can be as high as 100kΩ. Too high impedance can make feedback node prone to noise injection particularly if unshielded inductors are used.

### 7.6 Stability compensation

Follow the following steps to compensate the IC:

STEP 1: set the cross over frequency at 1/10 of the switching frequency

$$f_c = G_{cs} \times G_{ea} \times R_{comp} \times \frac{V_{ref}}{V_{out}} \times \frac{1}{2\pi \times C_{out}} \quad (3)$$

$$R_{comp} = \frac{2\pi \times C_{out}}{G_{cs} \times G_{ea} \times \frac{V_{ref}}{V_{out}}} \times \frac{1}{10} \times f_s \quad (4)$$

STEP 2: set the zero fz1 at 1/4 frequency of the cross over frequency.

$$C_{comp} = \frac{1}{2\pi R_{comp} \times \frac{1}{40} \times f_s} \quad (5)$$

STEP 3: If the output capacitors' ESR is high enough to cause a zero at lower than 4 times the cross frequency, an additional compensation capacitor Ccomp2 is required, and the proper value is



# GT5152

$$C_{comp2} = \frac{C_{out}R_{ESR}}{R_{comp}}$$

(6)

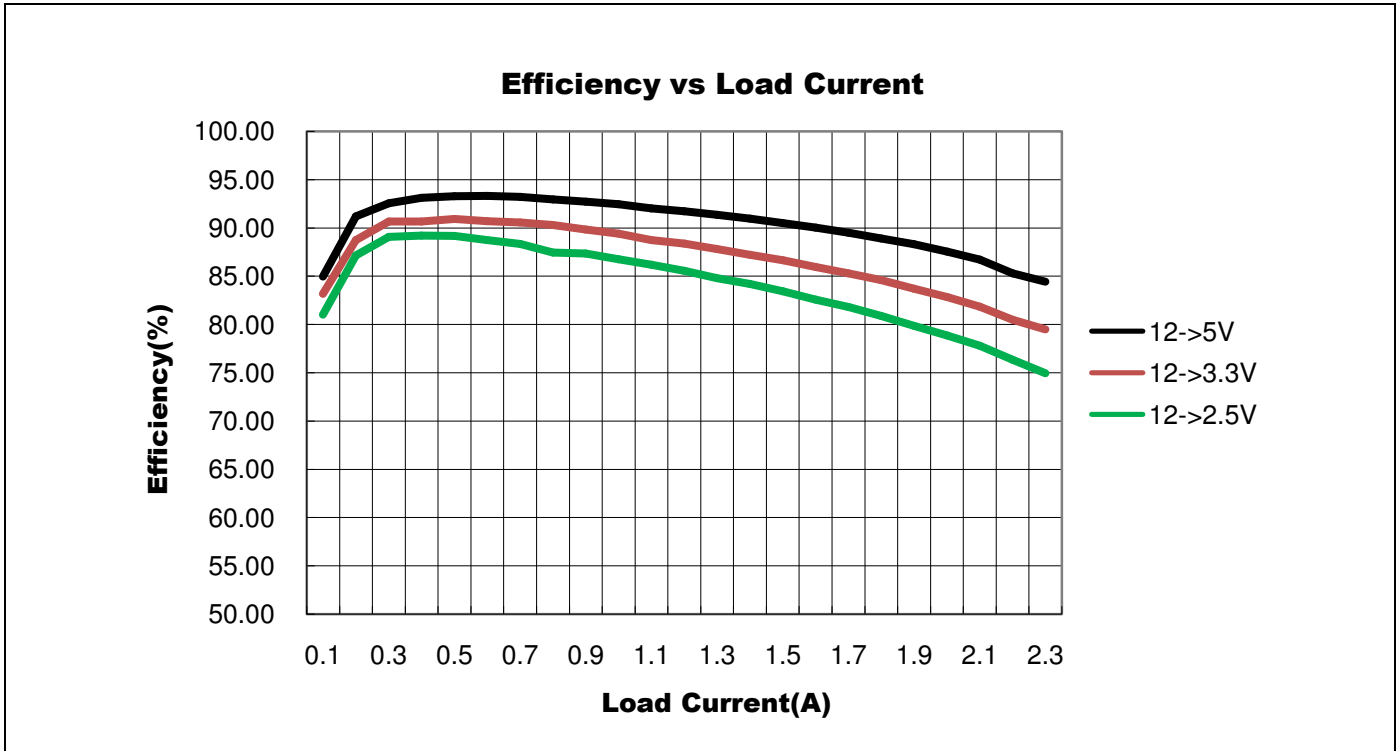

Figure 4. Efficiency vs. Load Current

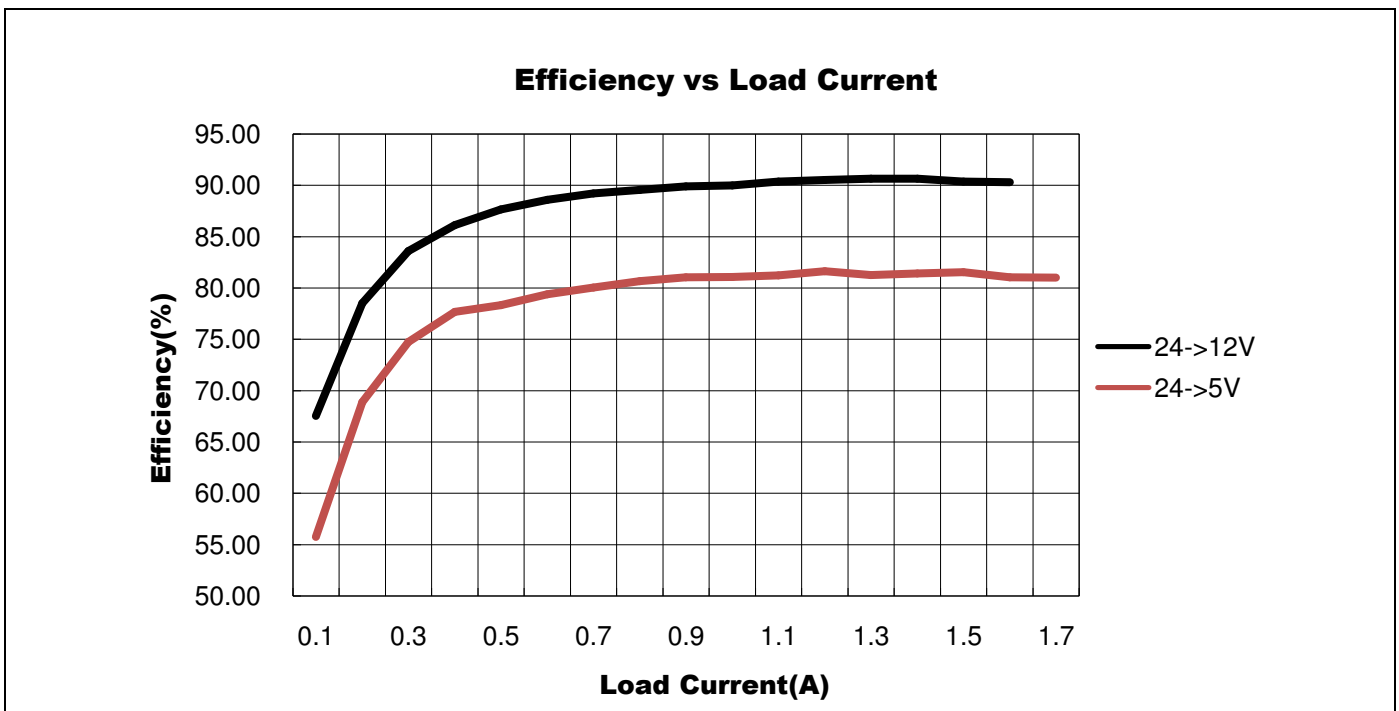

Figure 5. Efficiency vs. Load Current



# GT5152

## 8. Electrical Characteristics

### 8.1 Absolute Maximum Ratings

Condition	Min	Max
Supply Voltage ( $V_{IN}$ )	-0.3V	24V
Switch Voltage ( $V_{SW}$ )	-1.0V	$V_{IN}+1V$
Bootstrap Voltage ( $V_{BST}$ )	$V_{SW}-0.3V$	$V_{sw}+6V$
Feedback Voltage ( $V_{FB}$ )	-0.3V	6V
Enable Voltage ( $V_{EN}$ )	-0.3V	$V_{IN}$
Comp Voltage ( $V_{COMP}$ )	-0.3V	6V
Operating Junction Temperature	-40°C	150°C
Storage Temperature	-55°C	150°C
Lead Temperature		300°C

**Note:** Stress greater than those listed under Absolute Maximum Ratings may cause permanent damage to the device. This is a stress rating only and functional operation of the device at these or any other conditions outside those indicated in the operational sections of this specification are not implied. Exposure to absolute maximum rating conditions for extended periods may affect reliability.



# GT5152

## 8.2 Electrical Characteristics

Electrical Characteristics ( $V_{IN}=12V$ ,  $T_A=25^\circ C$  unless otherwise specified)

Parameter	Symbol	Conditions	Min.	Typ.	Max.	Units
Input Voltage Range	$V_{IN}$		4.75		24	V
Supply Quiescent Current	$I_Q$	$V_{IN}=12V$	-	1.0	2.0	mA
Supply Shutdown Current	$I_{SHDN}$	$V_{EN}=0V$	-	-	20	$\mu A$
Feedback Voltage	$V_{FB}$	$4.75 \leq V_{IN} \leq 24V$ , $V_{COMP} < 2V$	0.900	0.923	0.946	V
Soft-Start Current	$I_{SC}$	$V_{SS} = 0V$	-	6	-	$\mu A$
Soft-Start Period	$t_{SC}$	$C_{SS} = 0.1\mu F$	-	15	-	ms
HS Switch On Resistance	$R_{ONH}$	$I_{SW}=100mA$	-	0.18	-	$\Omega$
LS Switch On Resistance	$R_{ONL}$	$I_{SW}=100mA$	-	0.18	-	$\Omega$
Internal Switch Leakage	$I_{LEAK}$	$V_{EN}=0$ , $V_{DS}=24V$	-	-	10	$\mu A$
HS Switch Current Limit	$I_{LIMH}$		2.5	3.4	-	A
LS Switch Current Limit	$I_{LIML}$	From drain to source	-	1.1	-	A
COMP to Current Sense Transconductance	$G_{CS}$		-	3.5	-	A/V
Error Amplifier DC Gain	$A_{VEA}$		-	4000	-	V/V
Error Amplifier Transconductance	$G_{EA}$	$\Delta I_{COMP} = \pm 10\mu A$	-	800	-	$\mu A/V$
Switching Frequency	$f_{SW}$		-	350	-	kHz
Short Circuit Frequency		$V_{FB}=0V$	-	$f_{SW}/8$	-	kHz
Maximum Duty Cycle	$D_{MAX}$	$V_{FB}=1.0V$	-	90	93	%
Minimum on Time	$t_{ON(MIN)}$		-	150	-	ns
Enable Threshold Voltages	$V_{IH}$		1.2	1.29	1.3	V
Under Voltage Lockout Threshold Rising	$V_{UVLO}$		3.30	3.50	3.70	V
Under Voltage Lockout Threshold Hysteresis	$V_{UVL\_TH}$		-	120	250	mV
Thermal Shutdown Temperature	$T_{SHDN}$		-	150	-	$^\circ C$
Thermal Shutdown Temperature Hysteresis			-	40	-	$^\circ C$



# GT5152

## 8.3 Typical characteristics

**Test Condition:**  $C_{\mu}=10\mu\text{F}$ ,  $L=15\mu\text{F}$ ,  $C_{\text{BST}}=10\text{nF}$ ,  $C_{\text{SS}}=0.1\mu\text{F}$ ,  $C_{\text{COMP}}=10\text{nF}$ ,  $R_{\text{COMP}}=5.1\text{K}$ ,  $R_1=30\text{K}$ ,  $R_2=11.3\text{K}$

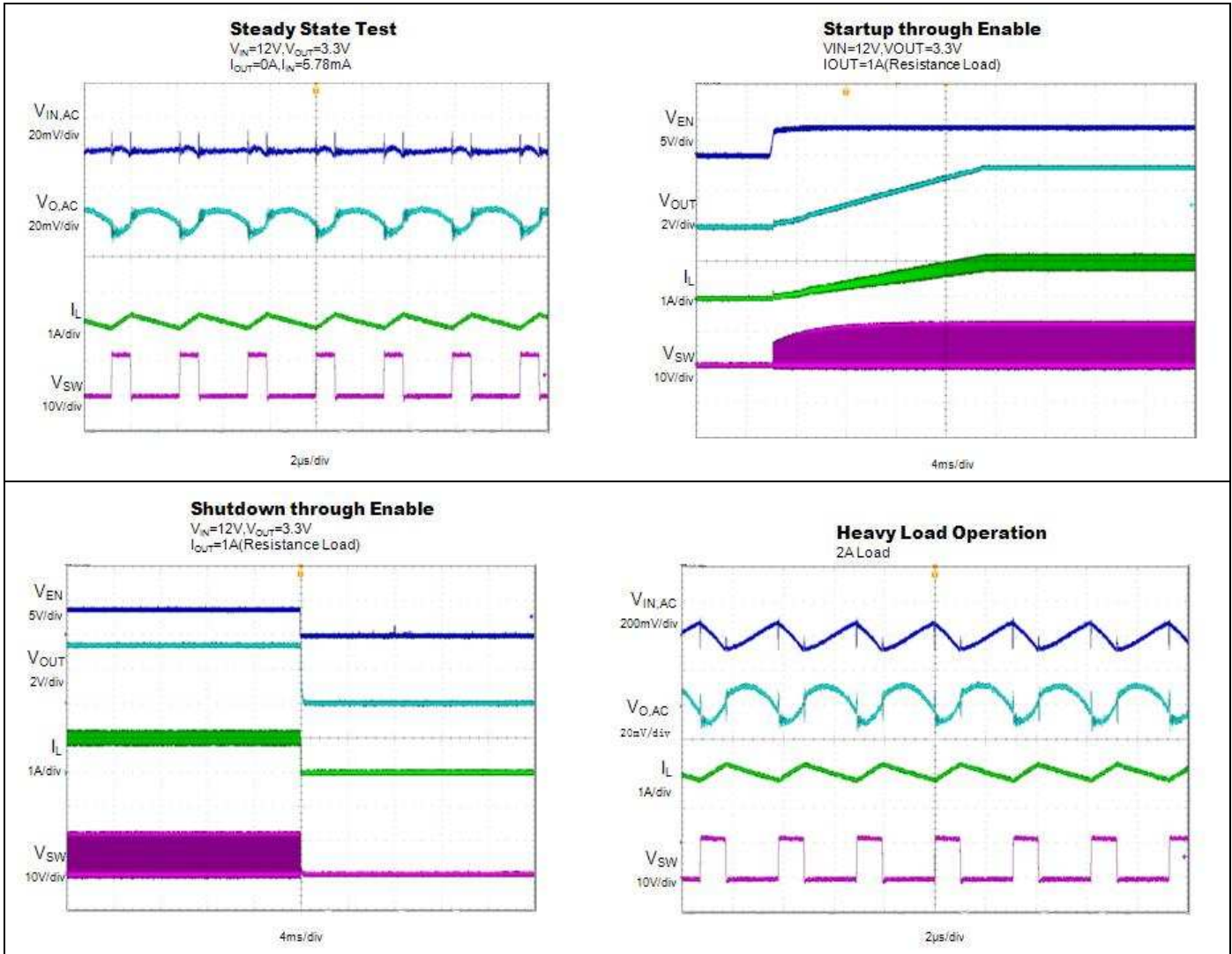



# GT5152

## Typical characteristics (Continued)

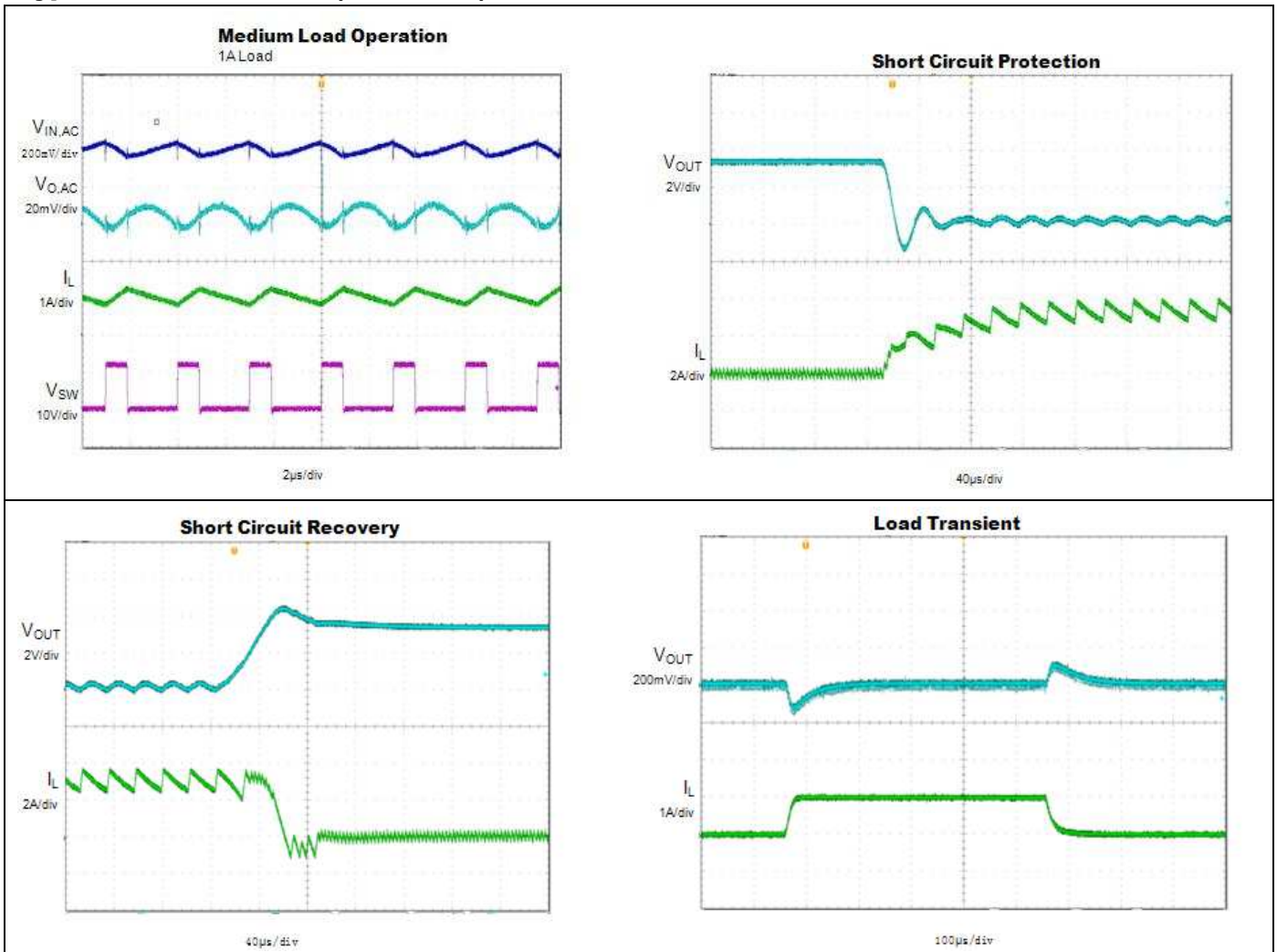



# GT5152

## 9. Typical Application Circuits

### 9.1 $V_{OUT}=3.3V$ , $I_{LOAD}=2A$ , $f_{SW}=350kHz$

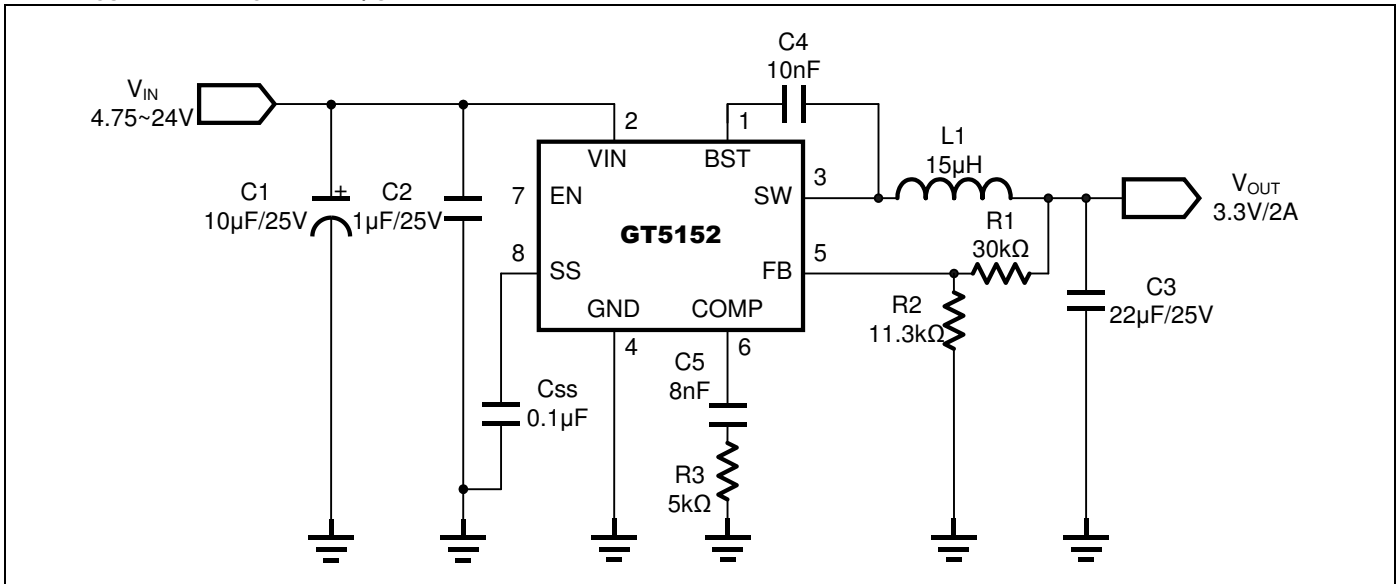

### 9.2 $V_{OUT}=5V$ , $I_{LOAD}=2A$ , $f_{SW}=350kHz$

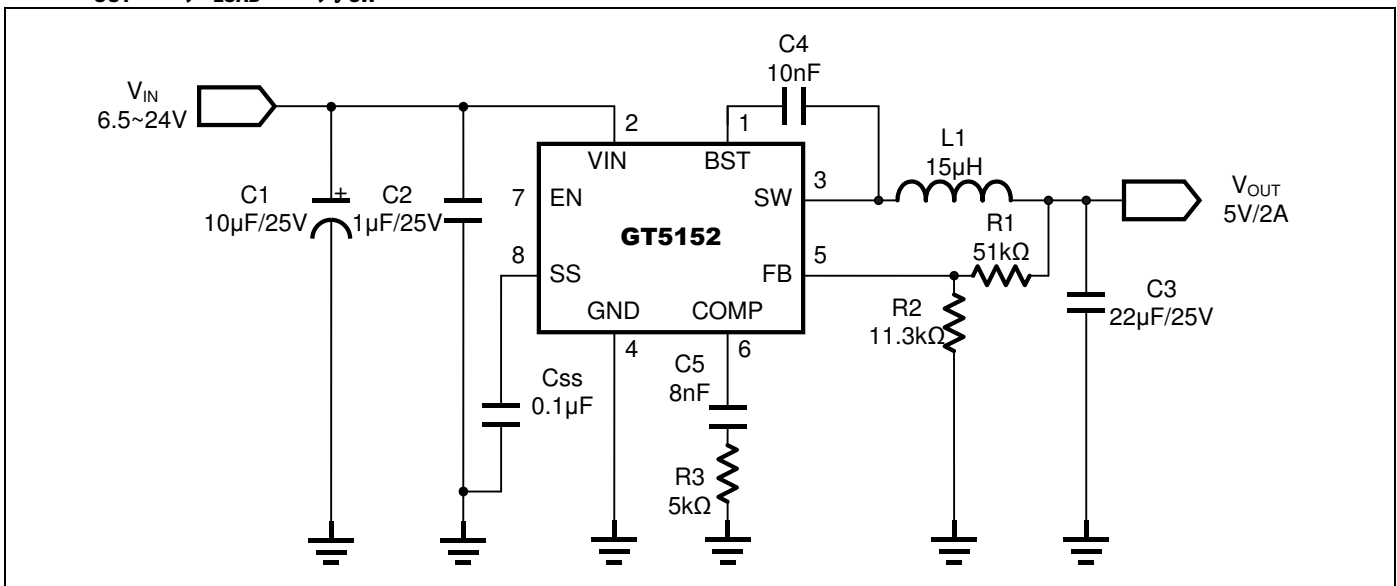



# GT5152

## 10. Ordering Information

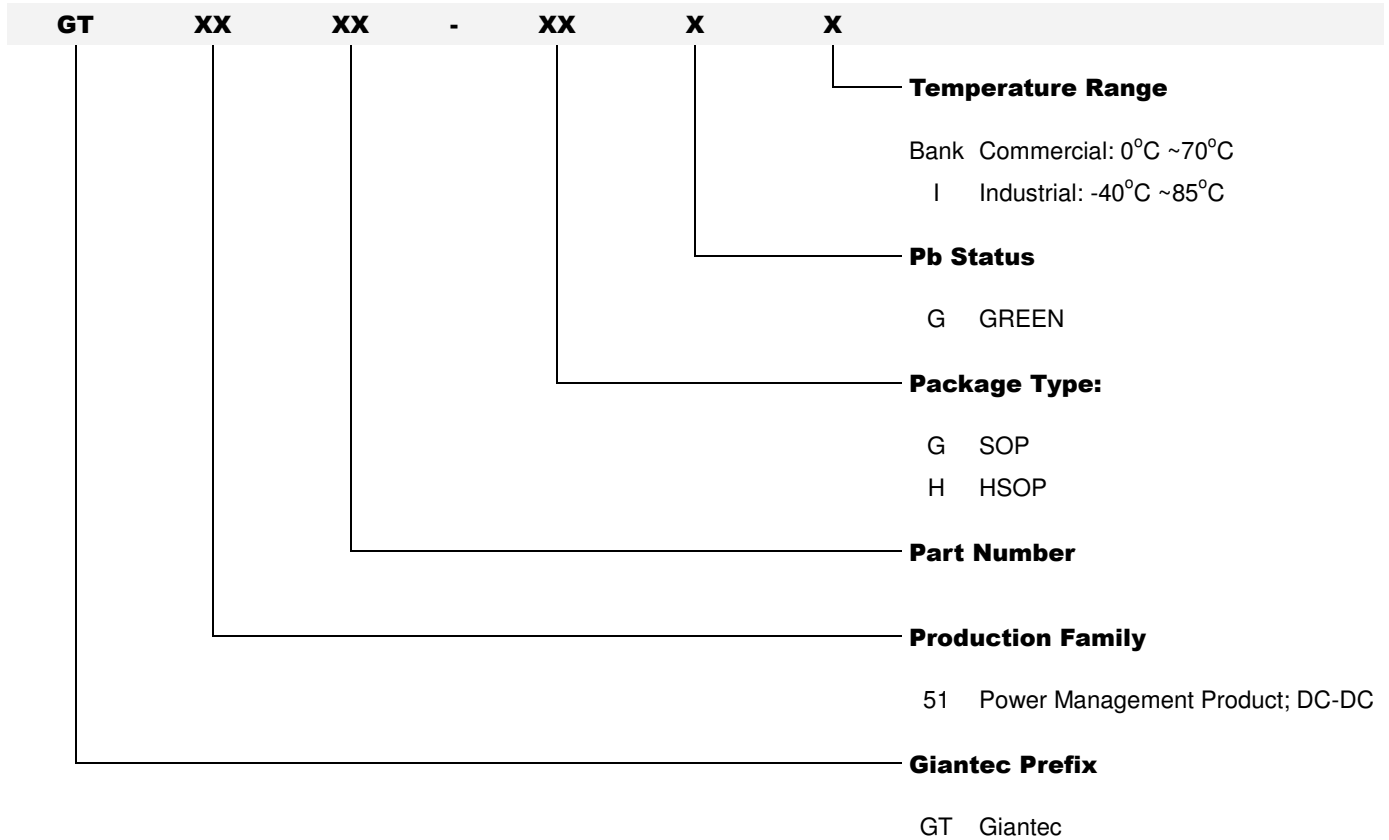

Order Number	Package Description	Package Option
GT5152-GGI-TR	5.1 x 4 mm SOP8	Tape and Reel 4000
GT5152-HGI-TR	5.1 x 4 mm HSOP8	Tape and Reel 4000



# GT5152

## 11. Part Markings

### 11.1 GT5152-GGI (Top View)

<u>G</u>	<u>T</u>	<u>5</u>	<u>1</u>	<u>5</u>	<u>2</u>	<u>G</u>	<u>G</u>	<u>I</u>
---	---	---	Lot Number			---	---	---
•		<u>Y</u>	<u>Y</u>	<u>W</u>	<u>W</u>	<u>S</u>	<u>V</u>	

#### GT5152GGI

##### Lot Number

States the last 9 characters of the wafer lot information

•

Pin 1 Indicator

YY

Seal Year

00 = 2000

01 = 2001

99 = 2099

WW

Seal Week

01 = Week 1

02 = Week 2

.

.

.

51 = Week 51

52 = Week 52

S

Subcon Code

J = ASESH

L = ASEKS

V

Die Version



# GT5152

## 12. Package Information

### 12.1 SOP8

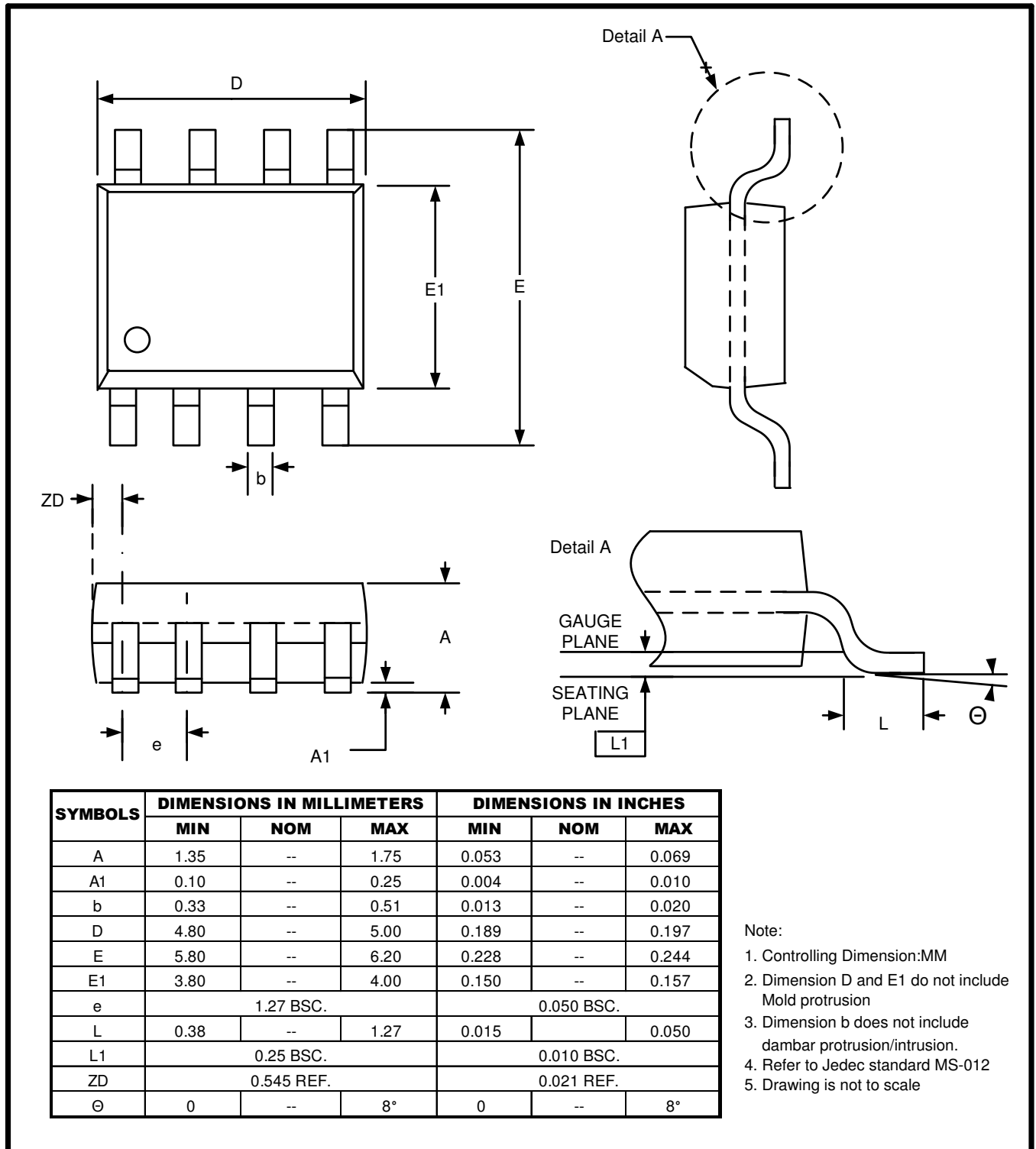



# GT5152

---

## 13. Revision History

Revision	Date	Descriptions
A2	Dec.,2012	Version Update
A1	Dec.,2012	Release Version
A0	Jan, 2012	Initial Version