

GT5010A



6Pin, Accurate Primary-Side Constant Current Driver

Advanced

1. Features

- High Accuracy $\pm 5\%$ CC Regulation
- No current overshoot during start-up
- Eliminates Opto-coupler and all secondary CC control circuitry
- Adaptive on time PWM control mode
- Innovative current sampling technology
- Programmable line compensation for tighter CC regulation
- Built-in compensation for transformer inductance tolerances
- Built-in Leading Edge Blanking (LEB)
- Cycle-by-Cycle Current Limiting
- VCC Under Voltage Lockout with Hysteresis (UVLO)
- Built-in two stage open voltage protection and inherent short load protection
- Built-in over temperature protection
- SOT-23-6 Package

2. General Description

GT5010A simplifies low power CC LED driver designs by eliminating opto-coupler and secondary control circuitry through patented current sampling technology. Very tight output voltage and current regulation is realized as shown in the **Figure 1** below.

GT5010A multi-mode operations are utilized to achieve high efficiency and audio & noise free. The frequency jittering could also greatly reduce EMI filter cost.

GT5010A utilizes 6 Pin package to realize accurate CC regulation for cost effective and the device reliability is also enhanced.

GT5010A offers rich protection features including Cycle-by-Cycle peak current limiting, VCC UVLO, OVP and Clamp. The controller continues attempting start-up until the

fault condition is removed. Every restart is a soft start. The GT5010A is available in an SOT-23-6 package.

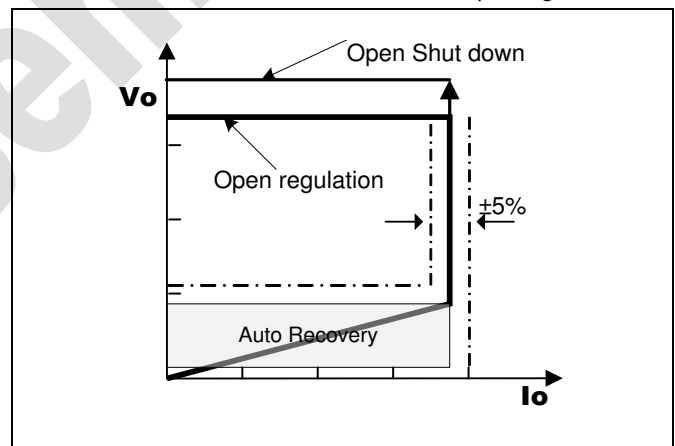

Figure 1. Typical CC Curve

3. Applications

- Sense LED Driver
- GU10 LED driver
- E14 LED driver
- E27 LED driver
- Others LED driver

Copyright © 2010 Giantec Semiconductor Inc. (Giantec). All rights reserved. Giantec reserves the right to make changes to this specification and its products at any time without notice. Giantec products are not designed, intended, authorized or warranted for use as components in systems or equipment intended for critical medical or surgical equipment, aerospace or military, or other applications planned to support or sustain life. It is the customer's obligation to optimize the design in their own products for the best performance and optimization on the functionality and etc. Giantec assumes no liability arising out of the application or use of any information, products or services described herein. Customers are advised to obtain the latest version of this device specification before relying on any published information and prior placing orders for products.



GT5010A

5. Pin Configuration

5.1 Pin Assignment Top View

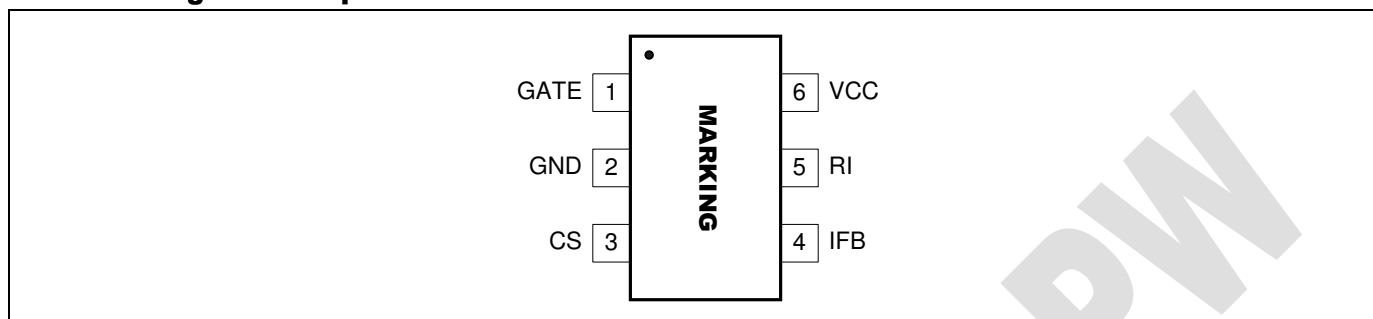

Figure 3. Pin Configuration (SOT-23-6 Package)

Note: Please see section “Part Markings” for detailed Marking Information.

5.2 Pin Descriptions

Pin #	Name	I/O	Function
1	GATE	O	Gate driver output for power MOSFET.
2	GND	-	IC ground
3	CS	I	This pin could detect the primary current by the voltage of sensing resistor connected from Source to GND.
4	IFB	I	Detecting the output information by current sampling
5	RI	I	Shut Down
6	VCC	-	IC power supply



GT5010A

6. Functional Description

The GT5010A is an innovative AC-DC controller in which a new proprietary primary-side control technology is employed to eliminate the opto-isolated feedback and secondary regulation circuits required in traditional designs. Additionally, some new technology is adopted to further improve performance.

6.1 Start-up

Due to an innovative internal start-up circuit and adaptive sleeping control technology adopted, when the system with GT5010A is powered on, pin VCC can be charged to a voltage higher than start-up threshold UVLO_off by a very large start-up resistor (>8MΩ), which causes GT5010A to enter into normal operation state. Meanwhile the VCC decoupling capacitor is allowed to use a smaller value (<2μF) compared with traditional design, therefore the start-time can be limited within a reasonable range. After the system enters into normal operation state, pin GATE of IC begins to output PWM driving signal to drive the external Power MOS switch and transfer power to the secondary stage, while a 1~2mA of operation current is required by the controller IC GT5010A. At the initial stage of start-up, the current consumed by GT5010A is provided by VCC decoupling capacitor, therefore the voltage on VCC decoupling capacitor will gradually decrease; at the same time, as the output voltage rises up, the voltage of auxiliary coil of the transformer increases proportionally also. Eventually, when the voltage of auxiliary coil reaches the voltage of decoupling capacitor, the auxiliary coil will replace the decoupling capacitor as power supply of the control IC GT5010A. The timing diagram of start-up is illustrated in **Figure.4**.

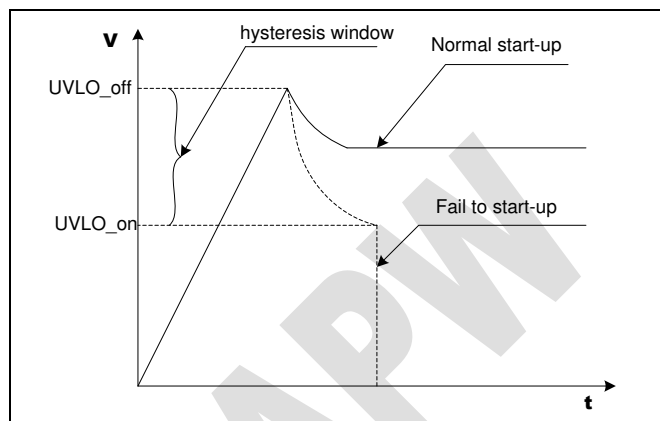

Figure 4. Timing Diagram of Start-up

As illustrated in **Figure.4**, a hysteresis window for internal UVLO comparator is necessary to prevent the control IC GT5010A from shutting down due to voltage dip during start-up.

6.3 Voltage Operation

In order to achieve a precise output-voltage regulation, the information about output and load condition must be real-time sensed. For primary side control flyback converter, the output information can be feedback to primary side of the transformer via the auxiliary winding. **Figure.5** illustrates the waveform of auxiliary winding. As shown, during power switch-on, rectified input voltage VIN is mapped to the Auxiliary winding with a coefficient -NAUX/NP. The voltage can be expressed as:

$$V_{AUX} = -V_{IN} \times \frac{N_{AUX}}{N_P}$$

Where NAUX is the turns of Auxiliary winding and NP is the turns of primary winding.

During power switch-off, the voltage at secondary-side winding is mapped to the auxiliary winding, which is expressed as:

$$V_{AUX} = \frac{N_{AUX}}{N_S} (V_O + V_D)$$

Where NS is the turns of secondary-side winding and VD is the voltage drop through the output rectifier diode.

GT5010A

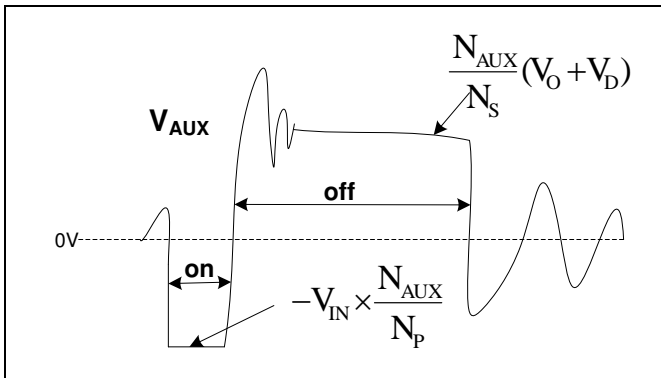

Figure 5. Waveform of Auxiliary Winding

As shown in the typical application circuit, R_{FB} is used to transform the V_{AUX} voltage to a feedback current signal which is fed into pin I_{fb} of GT5010. I_{fb} current is further regulated to the same level as an internal reference current I_{ref} which can be set by an external resistor R_I (connected to pin R_I), eventually, the regulated output voltage is equal to:

$$V_O = \frac{N_S}{N_{AUX}} \cdot \left(\frac{R_{FB}}{4R_I} + 1 \right) \cdot V_D$$

Where the internal reference current I_{ref} equals to $1/4R_I$. The recommended range for R_I is from 7k Ω to 20k Ω .

6.3 Constant Current(CC) Operation

In battery charging and LED lighting applications, constant output current is required regardless of output voltage. In order to regulate output current to a constant level, a ratio regulation algorithm is employed in the control IC.

Figure.6 illustrates the theory of the algorithm. As shown in **Figure.6** I_p is the peak current flowing through the primary-side sense resistor. When switch turns off, the peak current is mapped to secondary-side with a coefficient N_P/N_S . Due to the demagnetization of secondary-side winding, peak current linearly decreases to zero. The area of the triangle in **Figure.6** indicates the current integration of a cycle at secondary-side winding where t_{DM} is demagnetization time of the secondary-side inductance L_S , T is a switching period of the power converter system and $I_P \times N_P/N_S$ is the peak current of secondary-side winding. So, the average output current can be expressed as:

$$I_O = \frac{1}{2} \times \frac{T_{DM}}{T} \times \frac{N_P}{N_S} \times I_P = \frac{1}{2} \times \gamma \times \frac{N_P}{N_S} \times I_P$$

where γ is the ratio of the demagnetizing time to the switching period. Assuming the primary-side peak current I_P is regulate to a constant level, the constant output current can be obtained by regulating γ to a constant. In the power converter system based on GT5010A, constant current can be defined as:

$$I_O = 0.245 \times \frac{N_P}{N_S} \times I_P$$

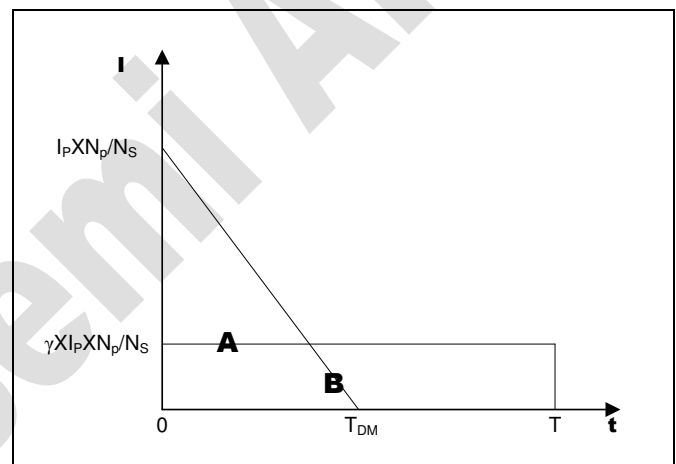

Figure 6. Diagram of output current

On the other hand, maximum output power can be expressed as:

$$P_{O_MAX} = \frac{1}{2} \times L_P \times I_{P_MAX}^2 \times f_{MAX}$$

Therefore, constant maximum output current can also be expressed as:

$$I_{O_MAX} = \frac{1}{2} \times \frac{1}{V_{O_MAX}} \times L_P \times I_{P_MAX}^2 \times f_{MAX}$$

Where I_{O_MAX} indicates the constant maximum output current, V_{O_MAX} indicates the maximum output voltage, L_P is the inductance of primary-side winding, I_{P_MAX} is the maximum primary peak current, f_{MAX} is the maximum operation frequency.

Obviously, for a given I_{O_MAX} , I_{P_MAX} , V_{O_MAX} , the maximum operation frequency can be defined through setting the



GT5010A

inductance L_P of primary-side winding.

6.4 Built-in Line Compensation

In the flyback converter system with GT5010A, line voltage compensation can be simply implemented and programmed by inserting a resistor R_{LN} between pin CS and current sense resistor R_s .

The line compensation voltage ΔV_{LN} can be calculated according to below equation:

$$\Delta V_{LN} = k \times V_{IN} \times \frac{N_{AUX}}{N_P} \times \frac{R_{LN}}{R_{FB}}$$

6.5 Mixed PWM/PFM operation

In order to trade off among different characteristics such as efficiency, no-load standby, audio noise, ripple, a mixed PWM/PFM operation mode is employed in GT5010A. Under constant voltage (CV) mode, from middle load to full load, the system with GT5010A operates on a pure PFM mode; from middle load to no-load, the system operates on a combined PWM/PFM mode. **Figure.7** illustrates the trend of frequency and CS peak following load-change.

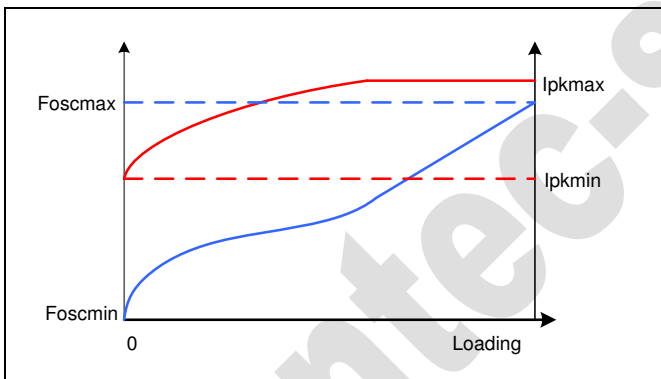

Figure 7. Fosc and Ipk vs. Loading

6.6 Protection Features

Complete protection features are integrated into GT5010A, which include built-in OVP, OTP, UVLO, OCP, output short/open protection and open loop protection.

With the pin CS, the GT5010A is able to monitor the peak primary current. This allows for cycle by cycle peak current control and limit. When the voltage level of pin CS hits the internal OCP threshold, over current is detected and the IC will immediately turn off the power MOS switch, until the next pulse is generated.

The VCC protections are implemented by UVLO and OVP. The output of GT5010A is shut down when VCC drops below UVLO (ON) threshold or rises above OVP threshold and the power system enters auto-restart sequence. In the event of output short or open, the UVLO (ON) and OVP can be triggered, and the converter can be shut down and enter into auto-restart sequence.

The over temperature protection (OTP) circuitry senses the die temperature. The threshold is set at 140 °C typically. When the die temperature rises above the threshold, the converter is shut down and enters into auto-restart sequence.

If open-loop happens, GT5010A can detect the fault condition and turn off the converter then enters into auto-restart sequence.

6.7 Sleeping control technology

In GT5010A, an innovative sleeping control technology is employed. As the converter load decreases from full-load to no-load, the current consumption of GT5010A dramatically drops from about 2mA to 200µA. Therefore, the efficiency of converter is significantly improved, and the standby is reduced to a very low level.



GT5010A

7. Electrical Characteristics

7.1 Absolute Maximum Ratings

Parameter	Symbol	Value	Units
Power supply (pin6)	VCC	-0.3 to VCC clamp	V
Cab compensation (pin5)	RI	-0.3 to 7	V
IFB input (pin4)	IFB	-0.3 to 7	V
CS input (pin3)	CS	-0.3 to 7	V
Maximum junction temperature	T _{JMAX}	150	°C
Storage temperature	T _{STO}	-55 to 150	°C
Lead Temperature (Soldering, 10secs)	T _{LEA}	260	°C

Note: Stress greater than those listed under Absolute Maximum Ratings may cause permanent damage to the device. This is a stress rating only and functional operation of the device at these or any other condition outside those indicated in the operational sections of this specification is not implied. Exposure to absolute maximum rating conditions for extended periods may affect reliability.



GT5010A

7.2 Electrical Characteristics

Parameter	Symbol	Test Conditions	Min.	Typ.	Max.	Unit
Supply Voltage (VCC) Section						
Start up current	I _{STARTUP}	VCC=13V	-	2	4	μA
Sleeping current	I _{DD_SD}	VCC=16V	-	250	-	μA
Operation current	I _{CC_OP}		-	1.5	2.5	mA
VCC Under Voltage Enter threshold	UVLO(ON)	VCC falling	8.1	9.0	9.8	V
VCC Under Voltage Exit threshold	UVLO(OFF)	VCC rising	13.5	14.5	15.5	V
VCC Over Voltage Protection Threshold	OVP	Ramp VCC until gate shut down	26	27.5	29	V
VCC Clamping voltage	VCC _{ZB}	I _{CC} =10mA	30	32.5	35	V
Frequency Section						
Maximum IC frequency	f _{MAX}		55	60	65	kHz
Minimal IC Frequency	f _{MIN}		200	260	320	Hz
Frequency shuffling range	Δf/Freq		-	±5	-	%
Current Sense Section						
Turn on LEB time	t _{LEB}		-	300	-	ns
Over current threshold	V _{TH}		925.9	940	954.1	mV
Input Impedance	Z _{SENSE}		100	-	-	kΩ
Soft start time	t _{SST}		-	2	-	ms
CC Protection control Section						
Reference current for open regulation	I _{REF}	R _I =10kΩ	23	25	27	μA
Over Temperature protection	OTP		-	150	-	°C
Output Section						
Gate Output Clamping	G_clamping		-	17	-	V
Gate Rising Time	t _R	C _L =0.5nF	-	44	-	nS
Gate Falling Time	t _F	C _L =0.5nF	-	30	-	nS
Max. Output Charge Current	I _{CH}		-	-	150	mA
Max. Output Sink Current	I _{SINK}		-	-	200	mA



GT5010A

8. Typical Performance Characteristics

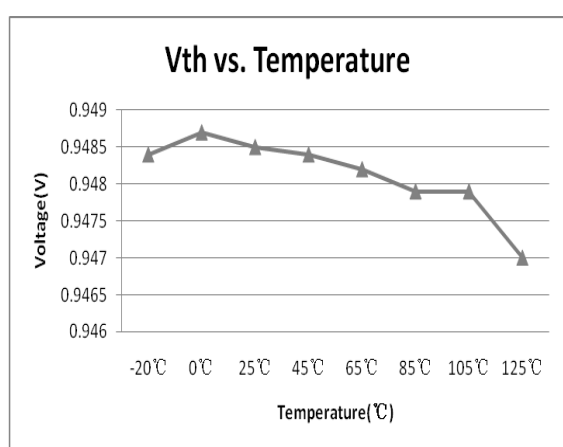
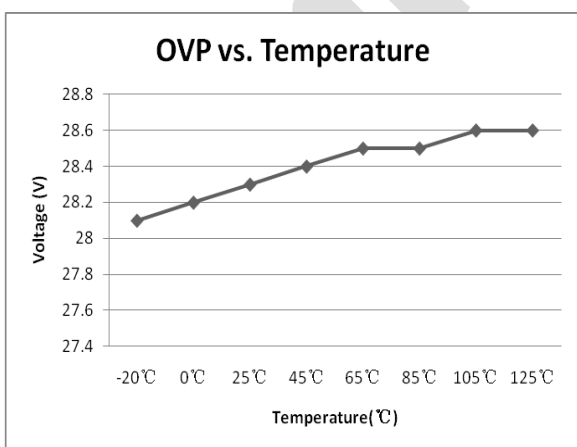
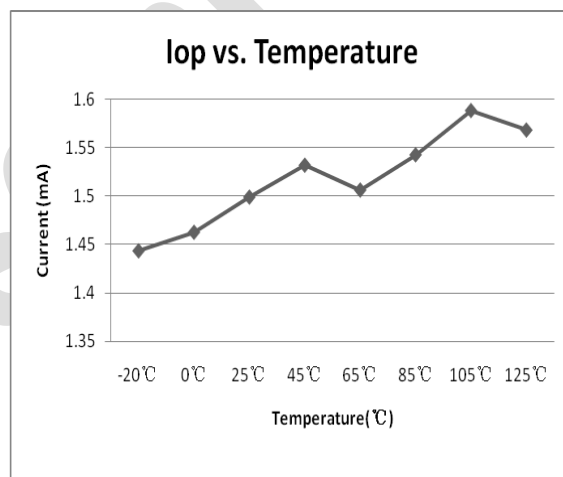
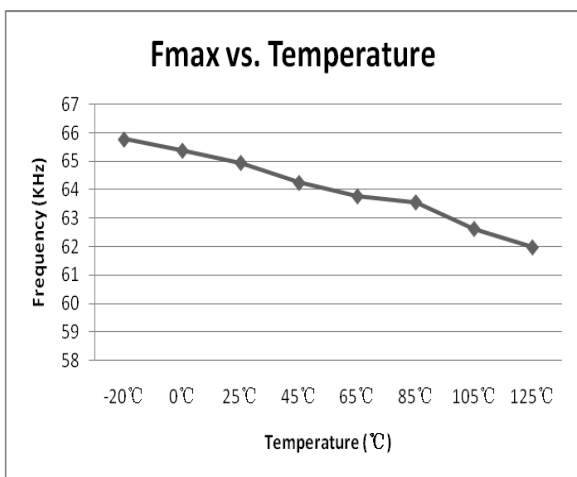
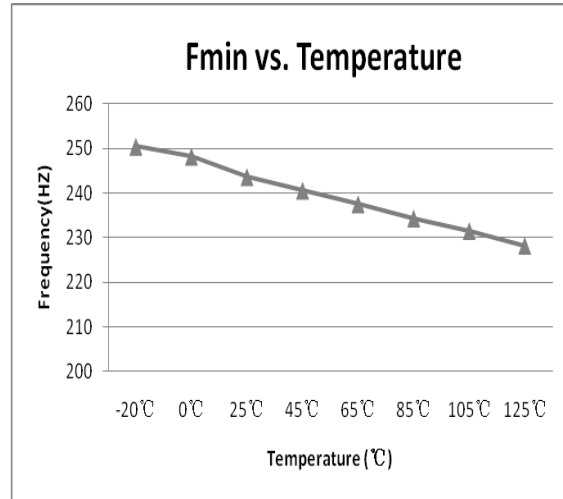
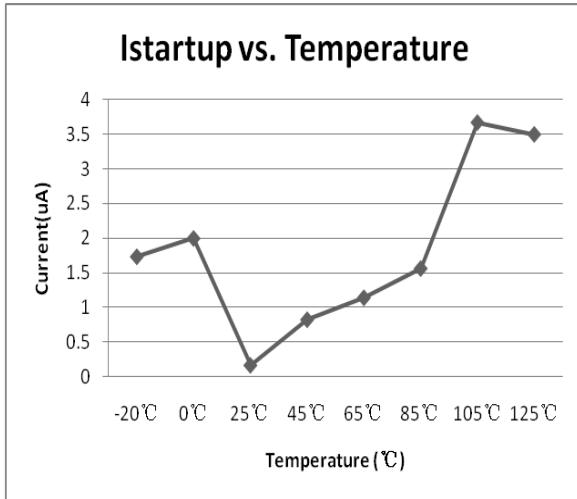



GT5010A

9. Typical Application Circuits

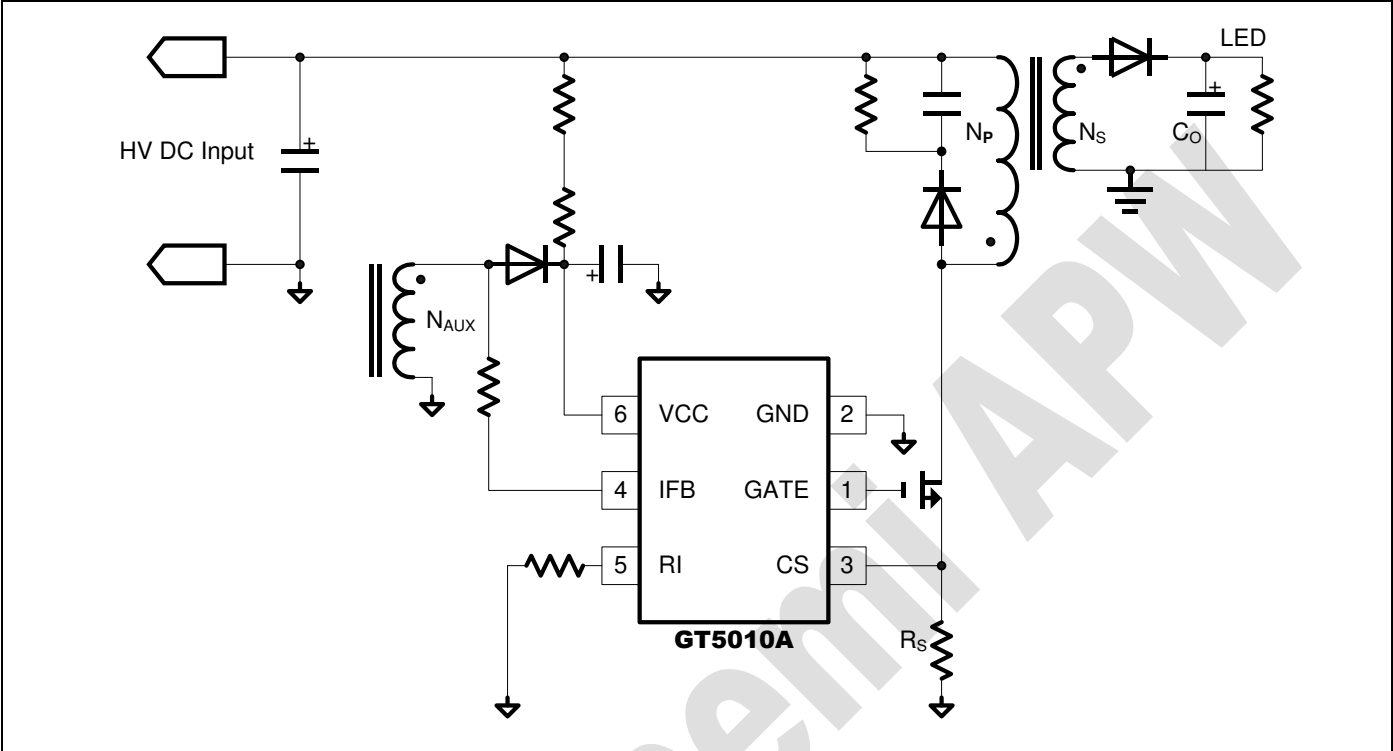



GT5010A

10. Ordering Information

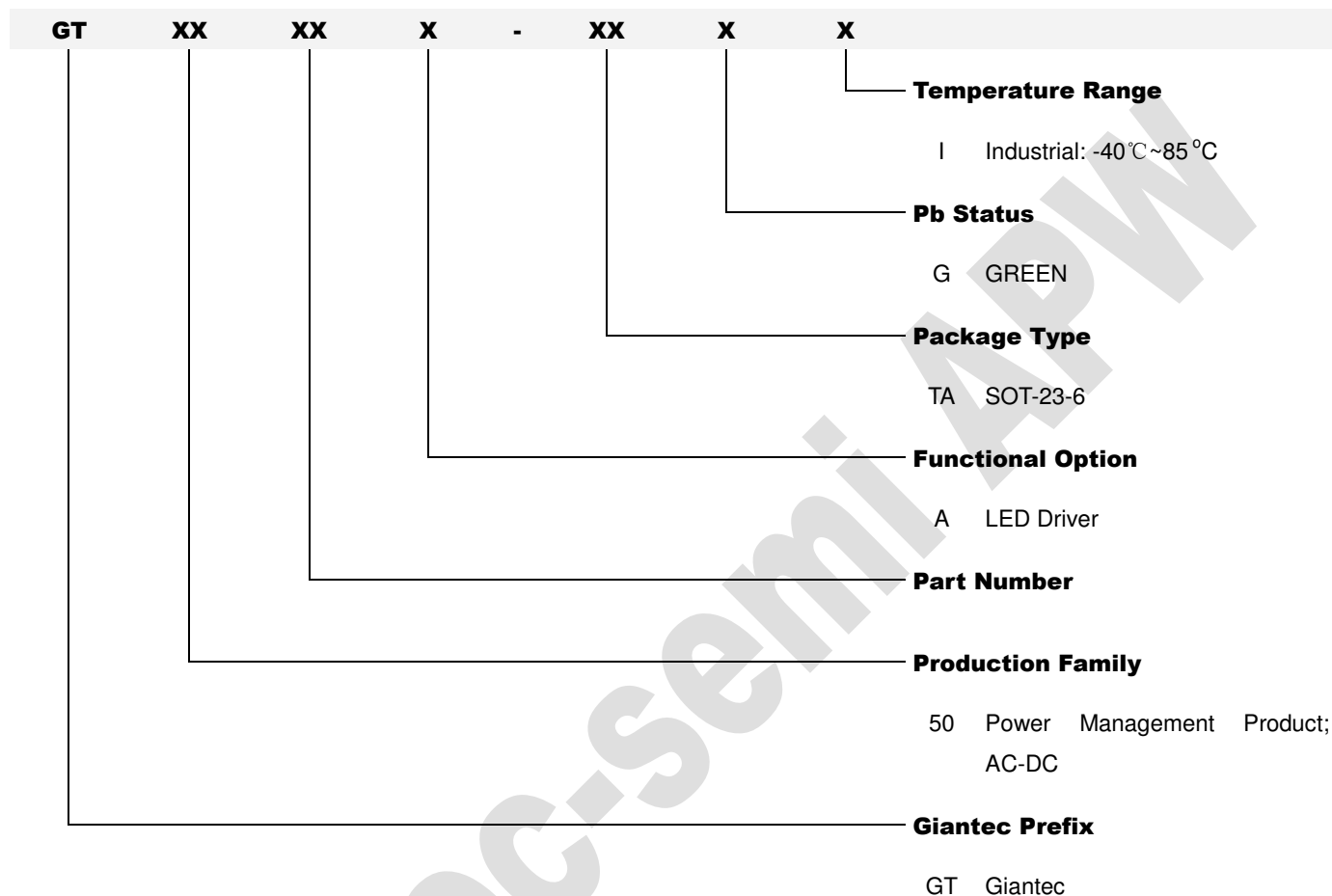

Order Number	Package Description	Package Option
GT5010A-TAGI-TR	SOT-23-6	Tape and Reel 3000



GT5010A

11. Part Markings

11.1 GT5010A-TAGI (Top View)



010A	GT5010A-TAGI		
●	Pin 1 Indicator		
Y	Seal Year	W	Seal Week
2010 (1st half year)	A	Week 01	A
2010 (2nd half year)	B	Week 02	B
2011 (1st half year)	C	
2011 (2nd half year)	D	Week 26	Z
2012 (1st half year)	E	Week 27	A
2012 (2nd half year)	F	Week 28	B
.....
2022 (2nd half year)	Z	Week 52	Z



GT5010A

12. Package Information

12.1 SOT-23-6

SOT-23-6L PACKAGE OUTLINE DIMENSIONS

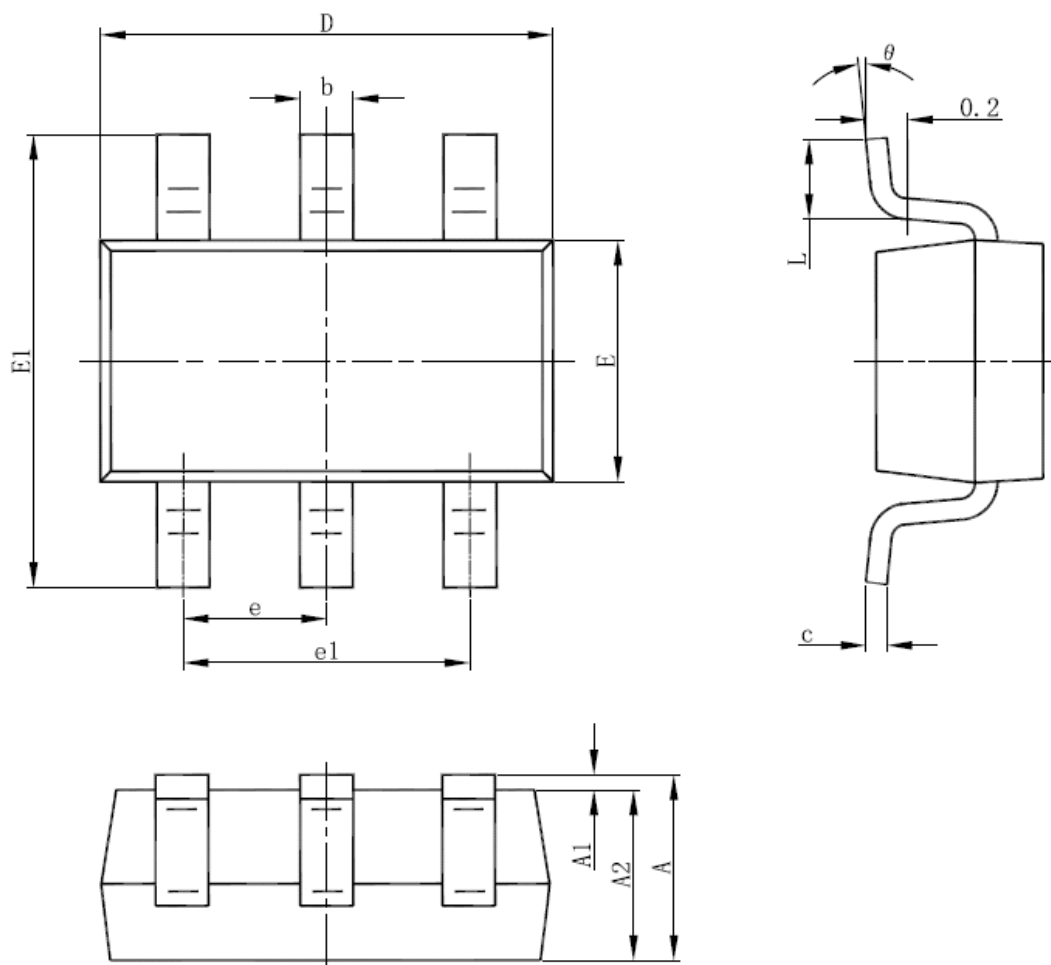



GT5010A

Table 1. Table of SOT-23-6 Package Dimensions

Symbol	Dimensions In Millimeters		Dimensions In Inches	
	Min	Max	Min	Max
A	1.000	1.300	0.039	0.051
A1	0.000	0.150	0.000	0.006
A2	1.000	1.200	0.039	0.047
b	0.300	0.500	0.012	0.020
c	0.100	0.200	0.004	0.008
D	2.800	3.020	0.110	0.119
E	1.500	1.700	0.059	0.067
E1	2.600	3.000	0.102	0.118
e	0.950 (BSC)		0.037 (BSC)	
e1	1.800	2.000	0.071	0.079
L	0.300	0.600	0.012	0.024
θ	0°	8°	0°	8°



GT5010A

13. Revision History

Revision	Date	Descriptions
A0	July., 2012	Initial Version

Giantec-semi APW