

GT24C128B

2-Wire

128Kb Serial EEPROM (Smart Card application)

Table of Content

1 FEATURES	3
2 DESCRIPTION.....	4
3 PIN CONFIGURATION	5
4 PIN DESCRIPTIONS.....	6
5 BLOCK DIAGRAM.....	7
6 DEVICE OPERATION	8
7 TIMING DIAGRAMS	11
8 ABSOLUTE MAXIMUM RATINGS	15
9 DC ELECTRICAL CHARACTERISTICS	16
10 AC ELECTRICAL CHARACTERISTICS	17
11 ORDERING INFORMATION.....	18
12 REVISION HISTORY.....	19

1 FEATURES

- Two-Wire Serial Interface, I²C™ Compatible
 - Bi-directional data transfer protocol
- Wide-voltage Operation
 - V_{CC} = 1.8V to 5.5V
- Speed: 400 KHz (1.8V) and 1 MHz (2.5V~5.5V)
- Standby current: 15 μA (max.), 1.8V
- Operating current: 3 mA (max.), 1.8V
- Hardware Data Protection
 - Write Protect Pin
- Sequential & Random Read Features
- Memory organization: 128Kb (16,384 x 8)
- Page Size: 64 bytes
- Page write mode
 - Partial page writes allowed
- Self timed write cycle: 5 ms (max.)
- Noise immunity on inputs, besides Schmitt trigger
- High-reliability
 - Endurance: 1 million cycles
 - Data retention: 10 years
- Wide operating temperature range
 - -30°C to +75°C

Copyright © 2010 Giantec Semiconductor Inc. (Giantec) All rights reserved. Giantec reserves the right to make changes to this specification and its products at any time without notice. Giantec products are not designed, intended, authorized or warranted for use as components in systems or equipment intended for critical medical or surgical equipment, aerospace or military, or other applications planned to support or sustain life. It is the customer's obligation to optimize the design in their own products for the best performance and optimization on the functionality and etc. Giantec assumes no liability arising out of the application or use of any information, products or services described herein. Customers are advised to obtain the latest version of this device specification before relying on any published information and prior placing orders for products.

2 DESCRIPTION

The GT24C128 is an industrial standard electrically erasable programmable read only memory (EEPROM) device that utilizes the industrial standard 2-wire interface for communications. The GT24C128 contains a memory array of 128K bits (16,384x8), which is organized in 64-byte per page.

The EEPROM operates in a wide voltage range from 1.8V to 5.5V, which fits most application. The product provides low-power operations and low standby current.

The GT24C128 is compatible to the standard 2-wire bus protocol. The simple bus consists of Serial Clock (SCL) and Serial Data (SDA) signals. Utilizing such bus protocol, a Master device, such as a microcontroller, can usually control one or more Slave devices, alike this GT24C128. The bit stream over the SDA line includes a series of bytes, which identifies a particular Slave device, an instruction, an address within that Slave device, and a series of data, if appropriate.

In order to refrain the state machine entering into a wrong state during power-up sequence or a power toggle off-on condition, a power on reset circuit is embedded. During power-up, the device does not respond to any instructions until the supply voltage (V_{CC}) has reached an acceptable stable level above the reset threshold voltage. Once V_{CC} passes the power on reset threshold, the device is reset and enters into the Standby mode. This would also avoid any inadvertent Write operations during power-up stage. During power-down process, the device will enter into standby mode, once V_{CC} drops below the power on reset threshold voltage. In addition, the device will be in standby mode after receiving the Stop command, provided that no internal write operation is in progress. Nevertheless, it is not recommended to send an command until the V_{CC} reaches its operating level.

3 PIN CONFIGURATION

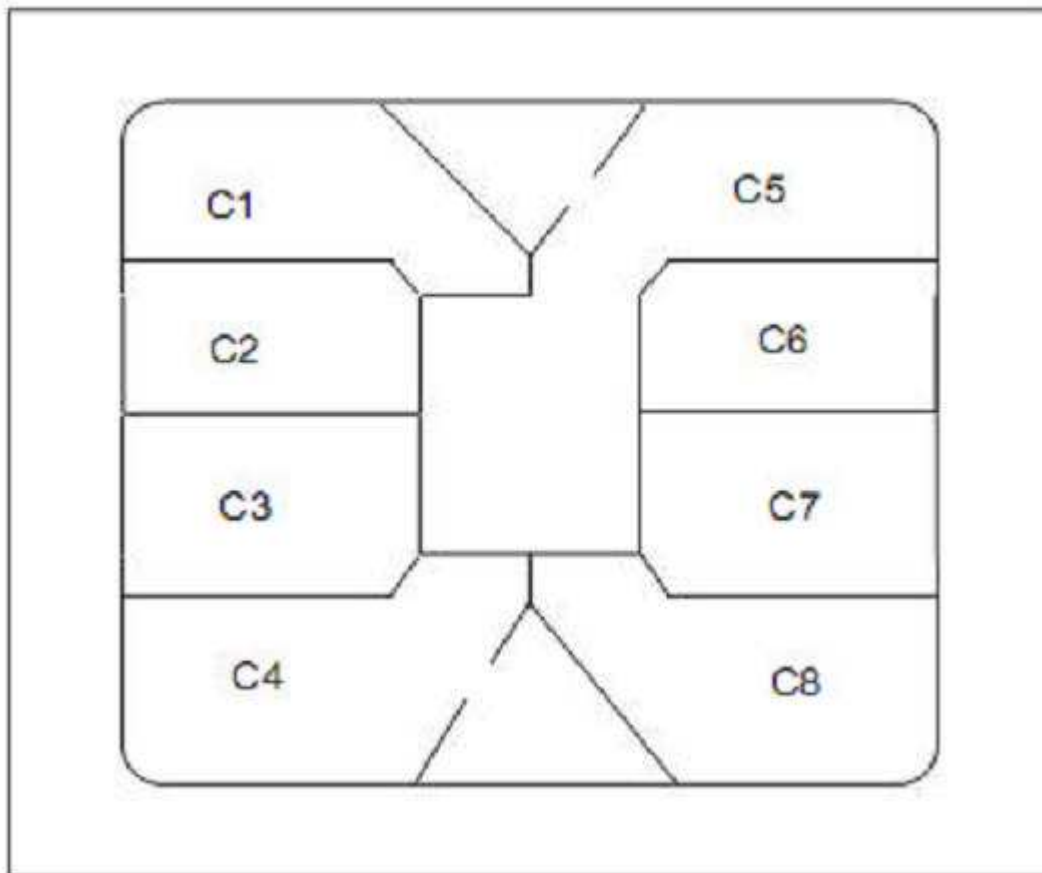

4 PIN DESCRIPTIONS**SCL (C3)**

This input clock pin is used to synchronize the data transfer to and from the device.

SDA (C7)

The SDA is a bi-directional pin used to transfer addresses and data into and out of the device. The SDA pin is an open drain output and can be wired with other open drain or open collector outputs. However, the SDA pin requires a pull-up resistor connected to the power supply.

Vcc (C1)

Supply voltage

GND (C5)

Ground of supply voltage

5 BLOCK DIAGRAM

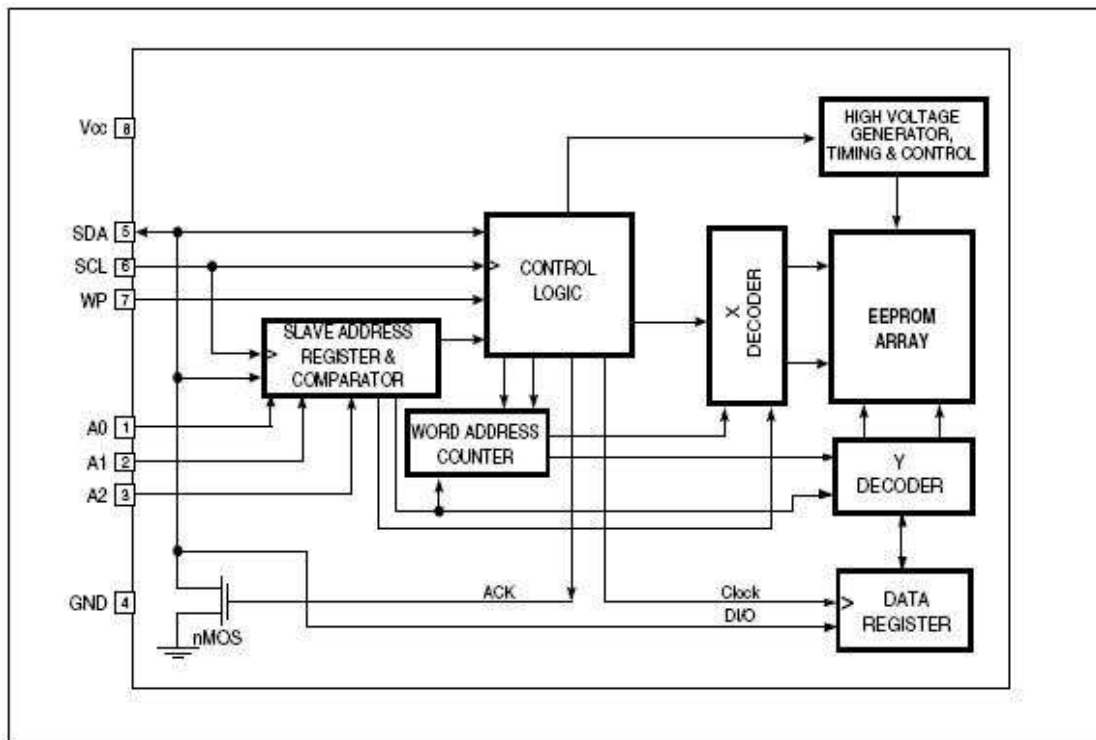

6 DEVICE OPERATION

The GT24C128 serial interface supports communications using industrial standard 2-wire bus protocol, such as I²C.

2-WIRE BUS

The two-wire bus is defined as Serial Data (SDA), and Serial Clock (SCL). The protocol defines any device that sends data onto the SDA bus as a transmitter, and the receiving devices as receivers. The bus is controlled by Master device that generates the SCL, controls the bus access, and generates the Start and Stop conditions. The GT24C128 is the Slave device.

The Bus Protocol:

Data transfer may be initiated only when the bus is not busy.

During a data transfer, the SDA line must remain stable whenever the SCL line is high. Any changes in the SDA line while the SCL line is high will be interpreted as a Start or Stop condition.

The state of the SDA line represents valid data after a Start condition. The SDA line must be stable for the duration of the High period of the clock signal. The data on the SDA line may be changed during the Low period of the clock signal. There is one clock pulse per bit of data. Each data transfer is initiated with a Start condition and terminated by a Stop condition.

Start Condition

The Start condition precedes all commands to the device and is defined as a High to Low transition of SDA when SCL is High. The EEPROM monitors the SDA and SCL lines and will not respond until the Start condition is met.

Stop Condition

The Stop condition is defined as a Low to High transition of SDA when SCL is High. All operations must end with a Stop condition.

Acknowledge (ACK)

After a successful data transfer, each receiving device is required to generate an ACK. The Acknowledging device pulls down the SDA line.

Reset

The GT24C128 contains a reset function in case the 2-wire bus transmission on is accidentally interrupted (e.g. a power loss), or needs to be terminated mid-stream. The reset is initiated when the Master device creates a Start condition. To do this, it may be necessary for the Master device to monitor the SDA line while cycling the SCL up to nine times. (For each clock signal transition to High, the Master checks for a High level on SDA.)

Standby Mode

While in standby mode, the power consumption is minimal. The GT24C128 enters into standby mode during one of the following conditions: a) After Power-up, while no Op-code is sent; b) After the completion of an operation and followed by the Stop signal, provided that the previous operation is not Write related; or c) After the completion of any internal write operations.

DEVICE ADDRESSING

The Master begins a transmission on by sending a Start condition, then sends the address of the particular Slave devices to be communicated. The Slave device address is 8 bits format as shown in Fig. 5.

The four most significant bits of the Slave address are fixed (1010) for GT24C128.

The next three bits, A0, A1 and A2, of the Slave address are specifically related to EEPROM. Up to eight GT24C128 units can be connected to the 2-wire bus.

The last bit of the Slave address specifies whether a Read or Write operation is to be performed. When this bit is set to 1, Read operation is selected. While it is set to 0, Write operation is selected.

After the Master transmits the Start condition and Slave address byte appropriately, the associated 2-wire Slave device, GT24C128, will respond with ACK on the SDA line. Then GT24C128 will pull down the SDA on the ninth clock cycle, signaling that it received the eight bits of data.

The GT24C128 then prepares for a Read or Write operation by monitoring the bus.

WRITE OPERATION

Byte Write

In the Byte Write mode, the Master device sends the Start condition and the Slave address information (with the R/W set to Zero) to the Slave device. After the Slave generates an ACK, the Master sends the byte address that is to be written into the address pointer of the GT24C128. After receiving another ACK from the Slave, the Master device transmits the data byte to be written into the address memory location. The GT24C128 acknowledges once more and the Master generates the Stop condition, at which time the device begins its internal programming cycle. While this internal cycle is in progress, the device will not respond to any request from the Master device.

Page Write

The GT24C128 is capable of 64-byte Page-Write operation. A Page-Write is initiated in the same manner as a Byte Write, but instead of terminating the internal Write cycle after the first data word is transferred, the Master device can transmit up to 63 more bytes. After the receipt of each data word, the EEPROM responds immediately with an ACK on SDA line, and the six lower order data word address bits are internally incremented by one, while the higher order bits of the data word address remain constant. If a byte address is incremented from the last byte of a page, it returns to the first byte of that page. If the Master device should transmit more than 64 bytes prior to issuing the Stop condition, the address counter will “roll over,” and the previously written data will be overwritten. Once all 64 bytes are received and the Stop condition has been sent by the Master, the internal programming cycle begins. At this point, all received data is written to the GT24C128 in a single Write cycle. All inputs are disabled until completion of the internal Write cycle.

Acknowledge (ACK) Polling

The disabling of the inputs can be used to take advantage of the typical Write cycle time. Once the Stop condition is issued to indicate the end of the host's Write operation, the GT24C128 initiates the internal Write cycle. ACK polling can be initiated immediately. This involves issuing the Start condition followed by the Slave address for a Write operation. If the EEPROM is still busy with the Write operation, no ACK will be returned. If the GT24C128 has completed the Write operation, an ACK will be returned and the host can then proceed with the next Read or Write operation.

Read OPERATION

Read operations are initiated in the same manner as Write operations, except that the (R/W) bit of the Slave address is set to “1”. There are three Read operation options: current address read, random address read and sequential read.

Current Address Read

The GT24C128 contains an internal address counter which maintains the address of the last byte accessed, incremented by one. For example, if the previous operation is either a Read or Write operation addressed to

the address location n , the internal address counter would increment to address location $n+1$. When the EEPROM receives the Slave Addressing Byte with a Read operation (R/W bit set to “ 1”), it will respond an ACK and transmit the 8-bit data byte stored at address location $n+1$. The Master should not acknowledge the transfer but should generate a Stop condition so the GT24C128 discontinues transmission. If 'n' is the last byte of the memory, the data from location '0' will be transmitted. (Refer to Figure 8. Current Address Read Diagram.)

Random Address Read

Selective Read operations allow the Master device to select at random any memory location for a Read operation. The Master device first performs a 'dummy' Write operation by sending the Start condition, Slave address and byte address of the location it wishes to read. After the GT24C128 acknowledges the byte address, the Master device resends the Start condition and the Slave address, this time with the R/W bit set to one. The EEPROM then responds with its ACK and sends the data requested. The Master device does not send an ACK but will generate a Stop condition. (Refer to Figure 9. RandomAddress Read Diagram.)

Sequential Read

Sequential Reads can be initiated as either a Current Address Read or Random Address Read. After the GT24C128 sends the initial byte sequence, the Master device now responds with an ACK indicating it requires additional data from the GT24C128. The EEPROM continues to output data for each ACK received. The Master device terminates the sequential Read operation by pulling SDA High (no ACK) indicating the last data word to be read, followed by a Stop condition. The data output is sequential, with the data from address n followed by the data from address $n+1, n+2 \dots$ etc. The address counter increments by one automatically, allowing the entire memory contents to be serially read during sequential Read operation. When the memory address boundary of the array is reached, the address counter “ rolls over” to address 0, and the device continues to output data. (Refer to Figure 10. Sequential Read Diagram).

7 TIMING DIAGRAMS

Fig. 1: Typical System Bus Configuration

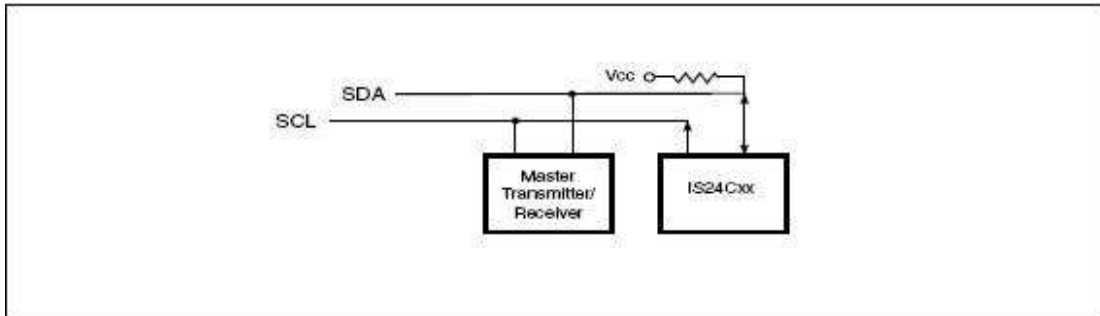

Fig. 2: output Acknowledge

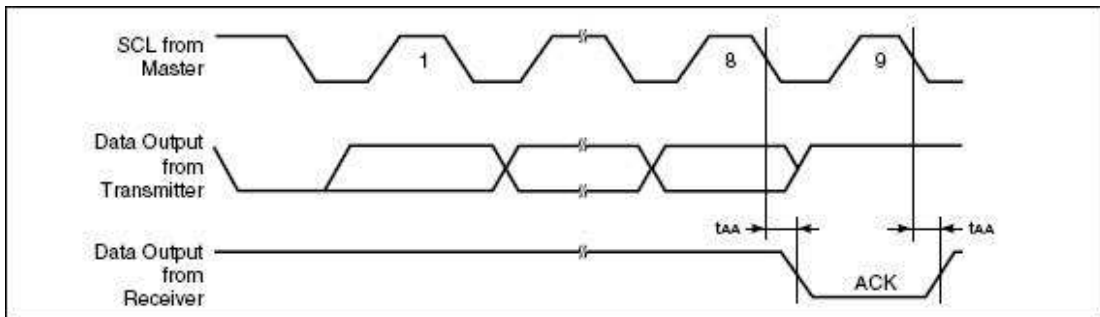

Fig. 3: Start and Stop Conditions

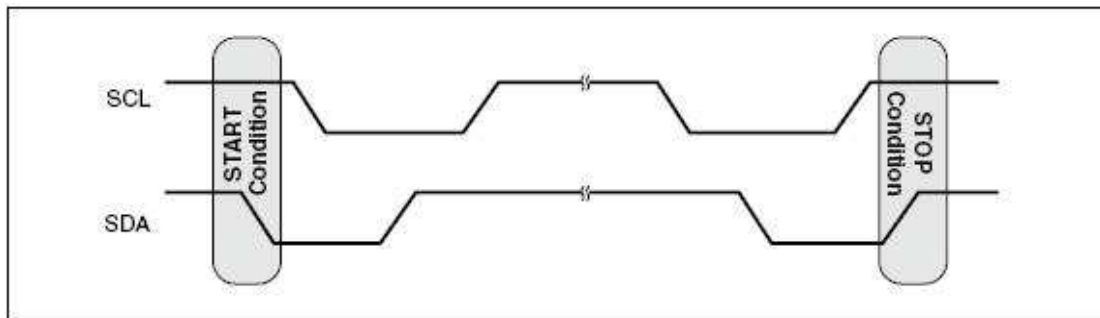

Fig. 4: Data Validity Protocol

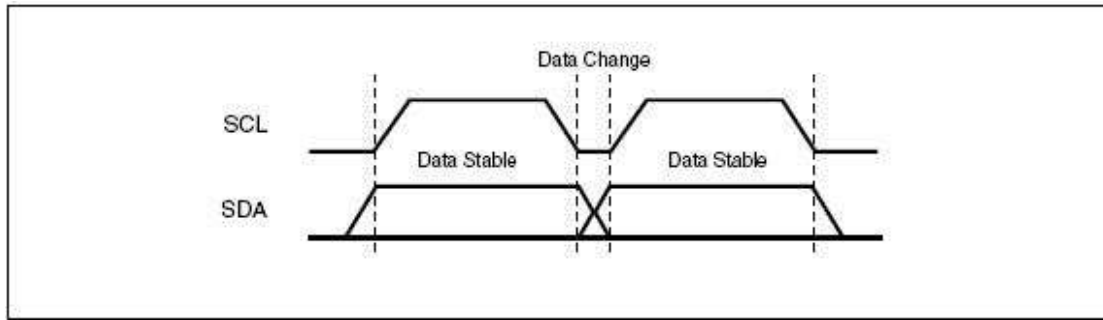

Fig. 5: Slave Address

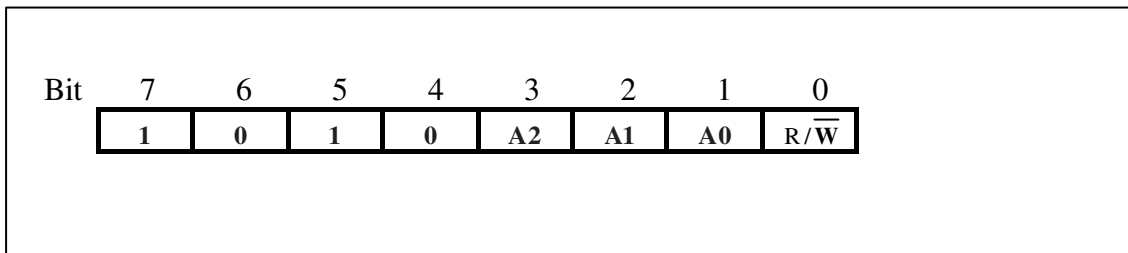

Fig. 6 : Byte Write

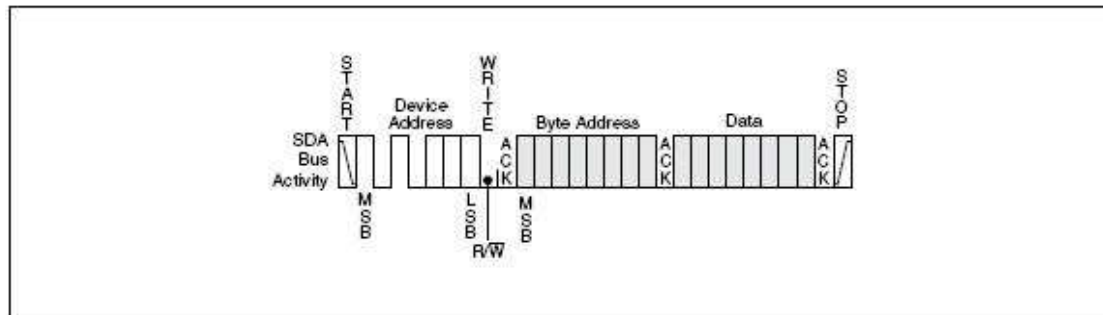

Fig. 7: Page Write

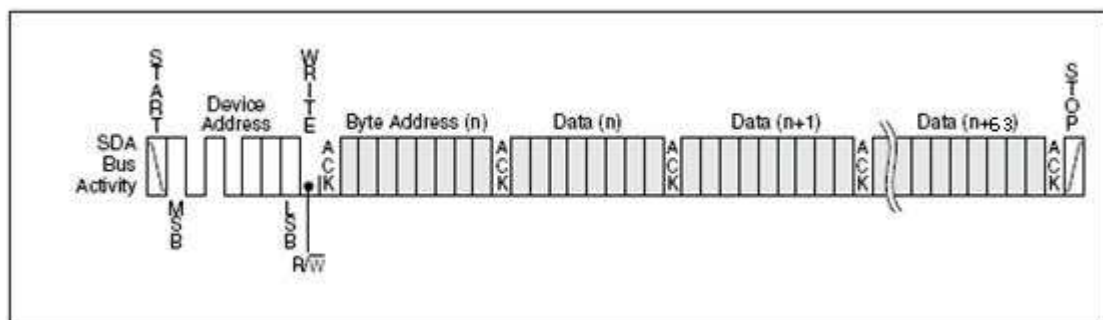

Fig. 8: Current Address Read

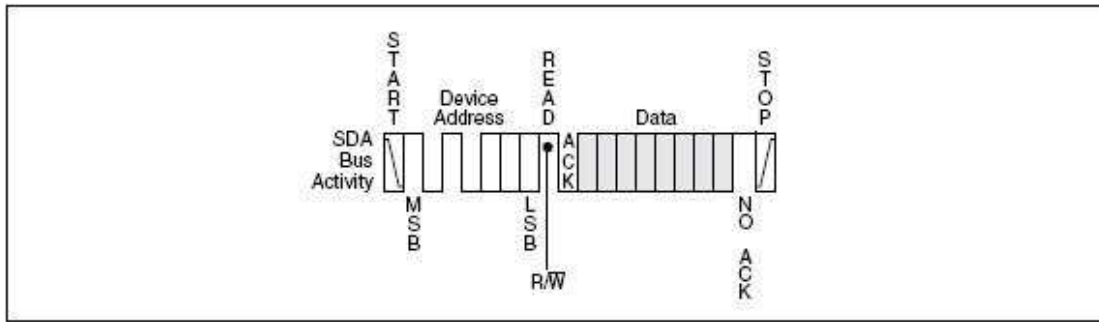

Fig. 9: Random Address Read

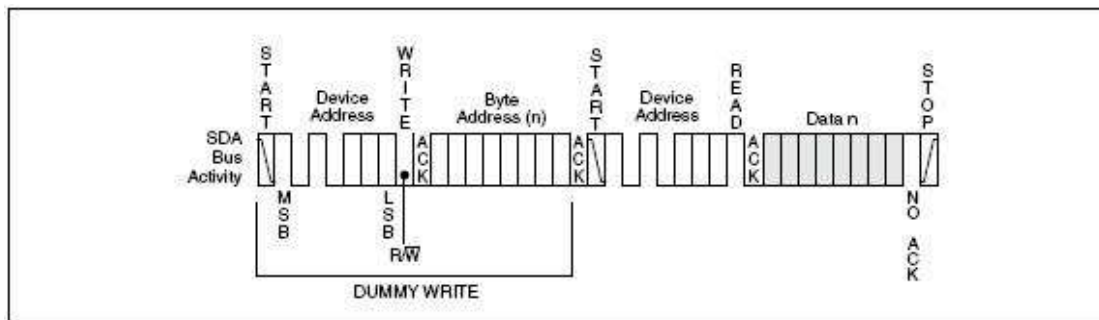
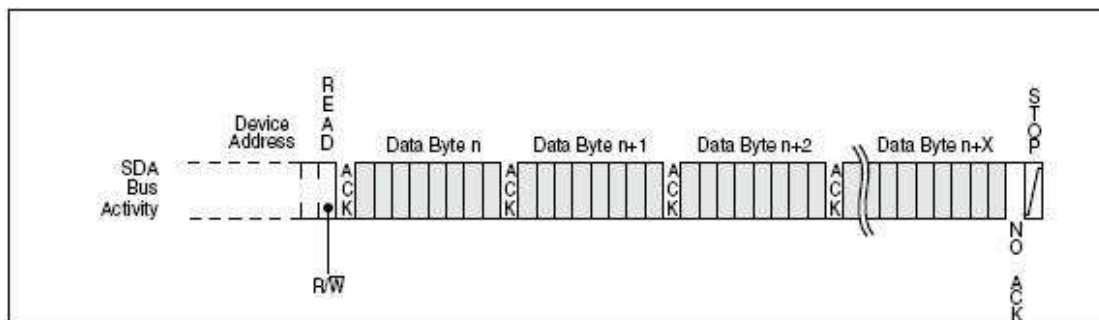

Fig. 10: Sequential Read



AC Timing

Fig. 11: Bus Timing

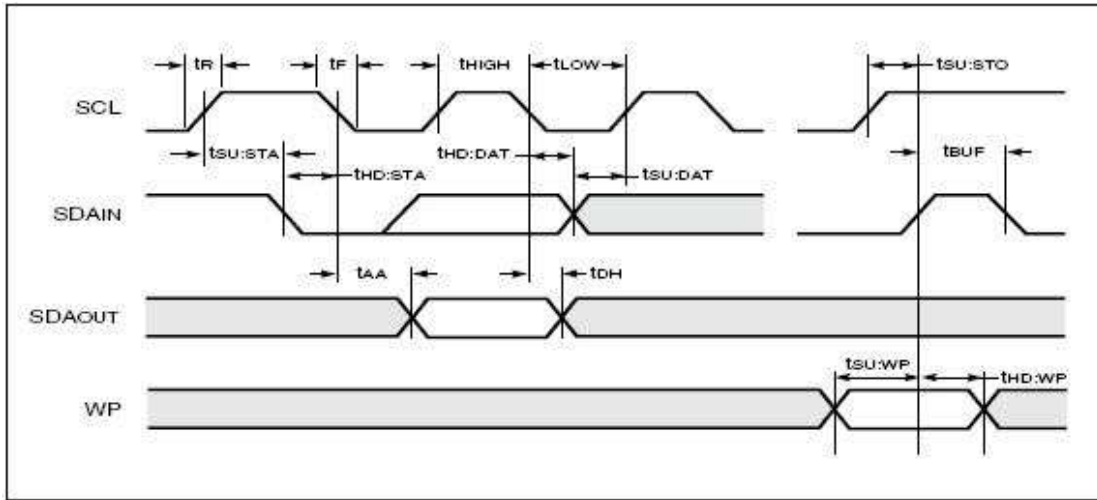
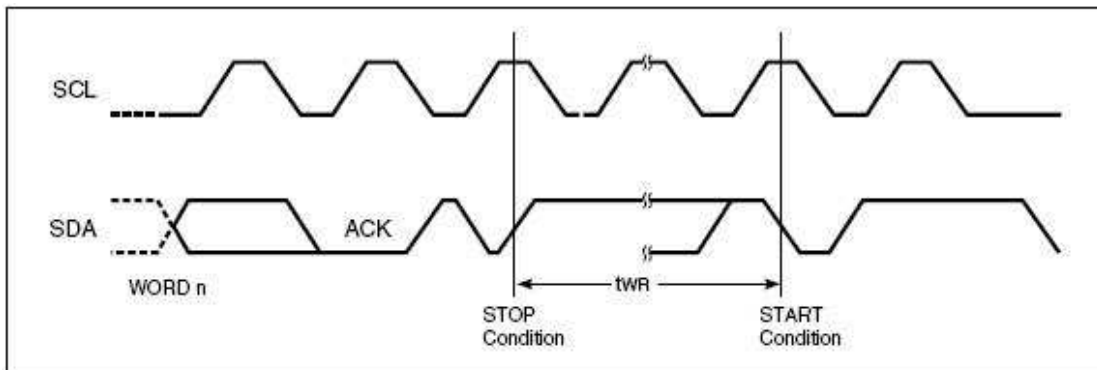

Fig. 12: Write Cycle Timing



8 ABSOLUTE MAXIMUM RATINGS

Symbol	Parameter	Value	Unit
V _S	Supply Voltage	-0.5 to + 6.5	V
V _P	Voltage on Any Pin	-0.5 to V _{CC} + 0.5	V
T _{BIAS}	Temperature Under Bias	-55 to +125	°C
T _{STG}	Storage Temperature	-65 to +150	°C
I _{OUT}	Output Current	5	mA

Notes:

Stress greater than those listed under ABSOLUTE MAXIMUM RATINGS may cause permanent damage to the device. This is a stress rating only and functional operation of the device at these or any other conditions outside those indicated in the operational sections of this specification is not implied. Exposure to absolute maximum rating conditions for extended periods may affect reliability.

OPERATING RANGE

Ambient Temperature (T_A)	V_{CC}
-30° C to +75° C	1.8V to 5.5V

CAPACITANCE (1,2)

Symbol	Parameter	Conditions	Max.	Unit
C _{IN}	Input Capacitance	V _{IN} = 0V	6	pF
C _{I/O}	Input /Output Capacitance	V _{I/O} = 0V	8	pF

Notes:

1. Tested initially and after any design or process changes that may affect these parameters and not 100% tested.
2. Test conditions: T_A = 25°C, f = 1 MHz, V_{CC} = 5.0V.

9 DC ELECTRICAL CHARACTERISTICS

$T_A = -30^{\circ}\text{C}$ to $+75^{\circ}\text{C}$, $V_{CC} = 1.8\text{V} \sim 5.5\text{V}$

Symbol	Parameter ^[1]	Vcc	Test Conditions	Min.	Max.	Unit
V_{CC}	Supply Voltage			1.8	5.5	V
V_{IH}	Input High Voltage			$0.7 * V_{CC}$	$V_{CC} + 0.5$	V
V_{IL}	Input Low Voltage			-0.3	$0.3 * V_{CC}$	V
I_{LI}	Input Leakage Current	5V	$V_{IN} = V_{CC} \text{ max}$	--	3	μA
I_{LO}	Output Leakage Current	5V		--	3	μA
V_{OL1}	Output Low Voltage	1.8V	$I_{OL} = 0.15 \text{ mA}$	—	0.2	V
V_{OL2}	Output Low Voltage	2.5V	$I_{OL} = 2.1 \text{ mA}$	—	0.4	V
I_{SB1}	Standby Current	1.8V		—	15	μA
I_{SB2}	Standby Current	2.5V		—	20	μA
I_{SB3}	Standby Current	5.0V		—	25	μA
I_{CC1}	Read Current	1.8V	Read at 400 KHz	—	0.8	mA
I_{CC2}	Write Current	1.8V	Write at 400 KHz	—	1	mA

Notes: ^[1]The parameters are characterized but not 100% tested.

10 AC ELECTRICAL CHARACTERISTICS

AC Characteristics - Industrial

T_A = -30° C to +75° C, Supply voltage = 1.8V to 5.5V

Symbol	Parameter ^{[1][2]}	1.8V ≤ V _{cc} < 2.5V		2.5V ≤ V _{cc} < 4.5V		4.5V ≤ V _{cc} ≤ 5.5V		Unit
		Min.	Max.	Min.	Max.	Min.	Max.	
F _{SCL}	SCK Clock Frequency		400		1000		1000	KHz
T _{LOW}	Clock Low Period	1200	—	600	—	600	—	ns
T _{HIGH}	Clock High Period	600	—	400	—	400	—	ns
T _R	Rise Time (SCL and SDA)	—	300	—	300	—	300	ns
T _F	Fall Time (SCL and SDA)	—	300	—	100	—	100	ns
T _{SU:STA}	Start Condition Setup Time	600	—	250	—	250	—	ns
T _{SU:STO}	Stop Condition Setup Time	600	—	250	—	250	—	ns
T _{HD:STA}	Start Condition Hold Time	600	—	250	—	250	—	ns
T _{SU:DAT}	Data In Setup Time	100	—	100	—	100	—	ns
T _{HD:DAT}	Data In Hold Time	0	—	0	—	0	—	ns
T _{AA}	Clock to Output Access time (SCL Low to SDA Data Out Valid)	100	900	50	400	50	400	ns
T _{DH}	Data Out Hold Time (SCL Low to SDA Data Out Change)	100	—	50	—	50	—	ns
T _{WR}	Write Cycle Time	—	5	—	5	—	5	ms
T _{BUF}	Bus Free Time Before New Transmission	1000	—	400	—	400	—	ns
T _{SU:WP}	WP pin Setup Time	600	—	600	—	600	—	ns
T _{HD:WP}	WP pin Hold Time	1200	—	1200	—	1200	—	ns
T	Noise Suppression Time	—	100	—	50	—	50	ns

Notes: ^[1] The parameters are characterized but not 100% tested.

^[2] AC measurement conditions:
 R_L (connects to V_{cc}): 1.3 kΩ (2.5V, 5.0V), 10 kΩ (1.8V)
 C_L = 100 pF
 Input pulse voltages: 0.3*V_{cc} to 0.7*V_{cc}
 Input rise and fall times: = 50 ns
 Timing reference voltages: half V_{cc} level

11 ORDERING INFORMATION

Voltage Range	Part Number*	Package
1.8V to 5.5V	GT24C128B-X07M-TR	Tape Module

12 REVISION HISTORY

Revision	Date	Descriptions
a0	Jan 2010	Initial draft