

## **4K bytes EEPROM Contactless Smart Card Conform to ISO/IEC 14443A Standard**

### **Table of contents**

1. Features .....	2
2. General Description .....	2
3. Typical Transaction Time .....	2
4. Functional Description .....	2
4.1 Block Description.....	2
4.2 Communication Principle.....	3
4.3 Data Integrity .....	4
4.4 Security .....	4
4.5 RF Interface.....	4
4.6 Memory Organization .....	4
4.7 Memory Access.....	6
5. Characteristics .....	6
6. Ordering Information .....	6
7. Revision History.....	7

### **Copyright Notice and Proprietary Information**

*Copyright © 2010 Giantec Semiconductor Inc. All rights reserved. This documentation is owned by Giantec Semiconductor Inc., and furnished under a license agreement. The documentation may be used or copied only in accordance with the term of the license agreement. No part of the documentation may be reproduced, transmitted, or translated, in any form or by any means, electronic, mechanical, manual, optical, or otherwise, without prior permission of Giantec Semiconductor Inc. or as expressly provided by the license agreement.*

## 1. Features

- Contactless transmission of data and supply energy
- Up to 100mm operation distance
- 13.56MHz operating frequency
- 106k bit/s data rate
- High level security data communication
- True anti-collision
- 4k bytes EEPROM, organized in 32 sectors with 4 blocks and 8 sectors with 16 blocks (one block consists of 16 bytes)
- User definable access condition for each memory block
- Data retention > 10 years
- Write endurance > 100,000 cycle
- Typical ticketing transaction < 100ms
- Three pass authentication (ISO/IEC DIS9798-2)
- Data encryption on RF-channel with replay attack protection
- Two keys per sector (per application) to support multi-application with key hierarchy
- Unique serial number for each device
- Transport key protects access to EEPROM on chip delivery
- Conform to ISO/IEC14443A standard
- Operation temperature range -25 to +70C

## 2. General Description

GT23SC4469 is contactless smart card IC compliant to ISO/IEC 14443A standard with 0.18um CMOS EEPROM process technology. GT23SC4469 has 4k bytes EEPROM. It has high performance security functions and contactless communication functions. GT23SC4469 can be used in payment card, public transportation card and many other applications.

## 3. Typical Transaction Time

- Identification of a card: 2.5ms (incl. Answer to Request, Anticollision and Select)
- Authentication: 2ms
- Read block (16 bytes): 2.5ms (excl. Authentication)
- Write block + Control Read: 4ms (excl. Authentication)
- Typical ticketing transaction: < 100ms

## 4. Functional Description

### 4.1 Block Description

The GT23SC4469 chip consists of 4k bytes EEPROM, RF Interface and Digital Control Unit. Energy and data are transferred via an antenna, which consists of a coil with a few turns directly connected to the GT23SC4469. No further external components are necessary.

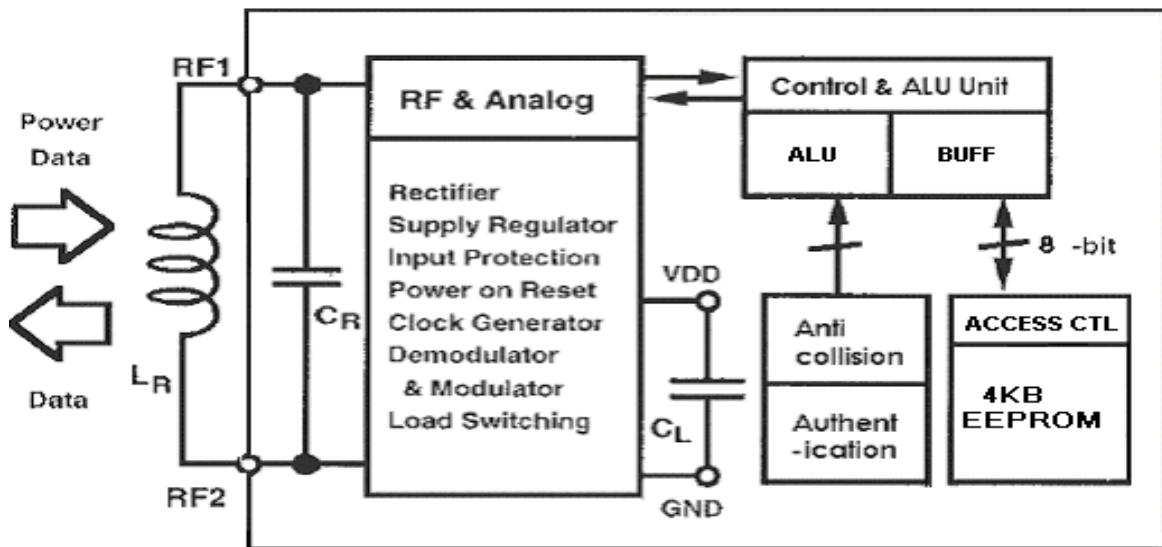

Fig. 1 Block Diagram

## 4.2 Communication Principle

The commands are initiated by PCD (Proximity Coupling Device) and controlled by the Digital Control Unit of GT23SC4469 according to the access conditions valid for the corresponding sector.

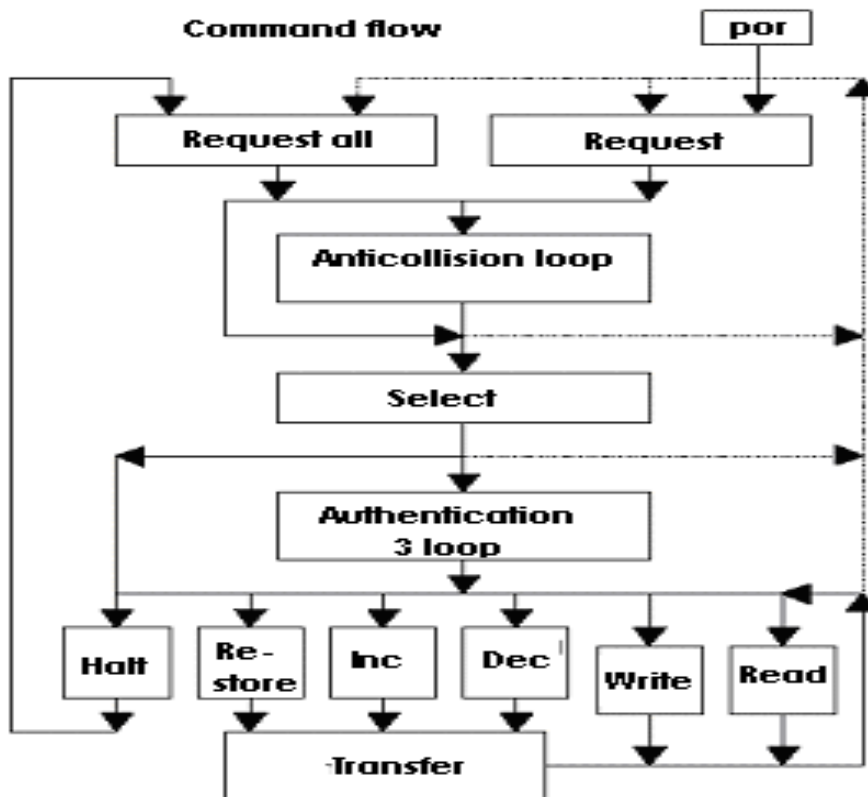

Fig. 2 Communication Flow

### 4.3 Data Integrity

To ensure reliable data transmission, following mechanisms are implemented in the contactless communication link between PCD and PICC:

- 16 bits CRC per block
- Parity bits for each byte
- Bit count checking
- Bit coding to distinguish between "1", "0", and no information
- Channel monitoring

### 4.4 Security

To provide high secure level, the triple pass authentication according to ISO/IEC 9798-2 is used in the following sequence:

- a. PCD specifies the sector to be accessed and chooses key A or B.
- b. PICC reads the secret key and access conditions from the sector trailer, then PICC sends a random number as the challenge to PCD (**pass one**).
- c. PCD calculates the Response using the secret key and additional input. The response, together with a random challenge from PCD, is then transmitted to PICC (**pass two**).
- d. PICC verifies the response of PCD by comparing it with its own challenge and then calculates the response to the challenge and transmits it (**pass three**).
- e. PCD verifies the response of PICC by comparing it to its own challenge.

**Note:** After transmission of the first random challenge the communication between PICC and PCD is encrypted.

### 4.5 RF Interface

The RF interface is according to the standard for contactless ISO/IEC 14443A compatible smart card. The carrier field from PCD is always present (with short pauses when transmitting). For both directions of data communication there is only one start bit at the beginning of each frame. Each byte is transmitted with a parity bit at the end. The LSB of the byte with the lowest address of the selected block is transmitted first. The maximum frame length is 163 bits.

### 4.6 Memory Organization

The 4096 x 8 bit EEPROM memory is organized in 32 sectors with 4 blocks of 16 bytes each and 8 sectors with 16 blocks of 16 bytes each. In the erased state the EEPROM cells are read logical "1", in the written state as a logical "0".

Sector	Block	0	1	2	3	4	5	6	7	8	9	10	11	12	13	14	15
39	15 Trailer	KEY A				Access Bits				KEY B							
	14 Data																
	13 Data																

	12 Data																		
	11 Data																		
	10 Data																		
	9 Data																		
	8 Data																		
	7 Data																		
	6 Data																		
	5 Data																		
	4 Data																		
	3 Data																		
	2 Data																		
	1 Data																		
	0 Data																		
.....																			
32	15 Trailer																		
	14 Data																		
	13 Data																		
	12 Data																		
	11 Data																		
	10 Data																		
	9 Data																		
	8 Data																		
	7 Data																		
	6 Data																		
	5 Data																		
	4 Data																		
	3 Data																		
	2 Data																		
	1 Data																		
	0 Data																		
31	3 Trailer																		
	2 Data																		
	1 Data																		
	0 Data																		
30	3 Trailer																		
	2 Data																		
	1 Data																		
	0 Data																		

29	3 Trailer	KEY A				Access Bits				KEY B			
.....													
1	3 Trailer	KEY A				Access Bits				KEY B			
	2 Data												
	1 Data												
	0 Data												
0	3 Trailer	KEY A				Access Bits				KEY B			
	2 Data												
	1 Data												
	0 Data	Manufacture Block											

Table1: Memory Organizations

### 4.7 Memory Access

Before any memory operation can be carried out, PICC has to be selected and authenticated as described previously. The possible memory operations for an addressed block depend on the key used and the access conditions stored in the associated sector trailer.

Memory Operations		
Operation	Description	Valid for Block Type
Read	Reads one memory block	Value & Sector Trailer
Write	Writes one memory block	Value & Sector Trailer
Increment	Increments the contents of a block and stores the result in the internal data register	Value
Decrement	Decrements the contents of a block and stores the result in the internal data register	Value
Transfer	Writes the contents of the internal data register to a block	Value
Restore	Reads the contents of a block into the internal data register	Value

Table 2: Memory Operations

## 5. Characteristics

PARAMETER	CONDITIONS	MIN.	TYP.	MAX.
Operating frequency			13.56MHz	
Input capacitance	25C, VCC = 3 V		16.5 pF	

## 6. Ordering Information

Part Number	Package
GT23SC4469-MFxxxW	Sorted Wafer

---

GT23SC4469-MFxxxWBD	Sorted Dies with Back Grinding and Die Saw
GT23SC4469-MFxxxP	COB
GT23SC4469-X10MFxxxT	Module

## 7. Revision History

<i>REV</i>	<i>History</i>	<i>Page</i>	<i>Date</i>
1.0	Initial Version	--	3/31/2010

### ***ATTENTION PLEASE!***

All information contained in this document is subject to change without notice, further information is confidential and on request. Please contact us for the latest document.