

**FEATURES**

- 12/10/8-Bit Monotonic Dual DACs in 10 lead MSOP Package
- Wide Output Voltage Swing
- 100  $\mu$ A per DAC
- On Board Reference
- Serial Interface with three-wire SPI/QSPI and Microwire Interface Compatible
- 8 $\mu$ s Full-Scale Settling Time

with guaranteed monotonic behavior. They include a 1.25V reference for ease of use and flexibility. The reference output is available on a separate pin and can be used to drive the reference input of each DAC. Alternately, each DAC can be driven by an external reference. The operating supply range is 2.7V to 5.5V.

The input interface is an easy to use three-wire SPI/QSPI compatible interface. Each DAC can be individually controlled and has a double buffered digital input.

**APPLICATIONS**

- Battery-Powered Applications
- Industrial Process Control
- Digital Gain and Offset Adjustment

**OVERVIEW**

The ICM7362, ICM7342 and ICM7322 are Dual 12-Bit, 10-Bit and 8-Bit wide output voltage swing DACs respectively,

**BLOCK DIAGRAM**

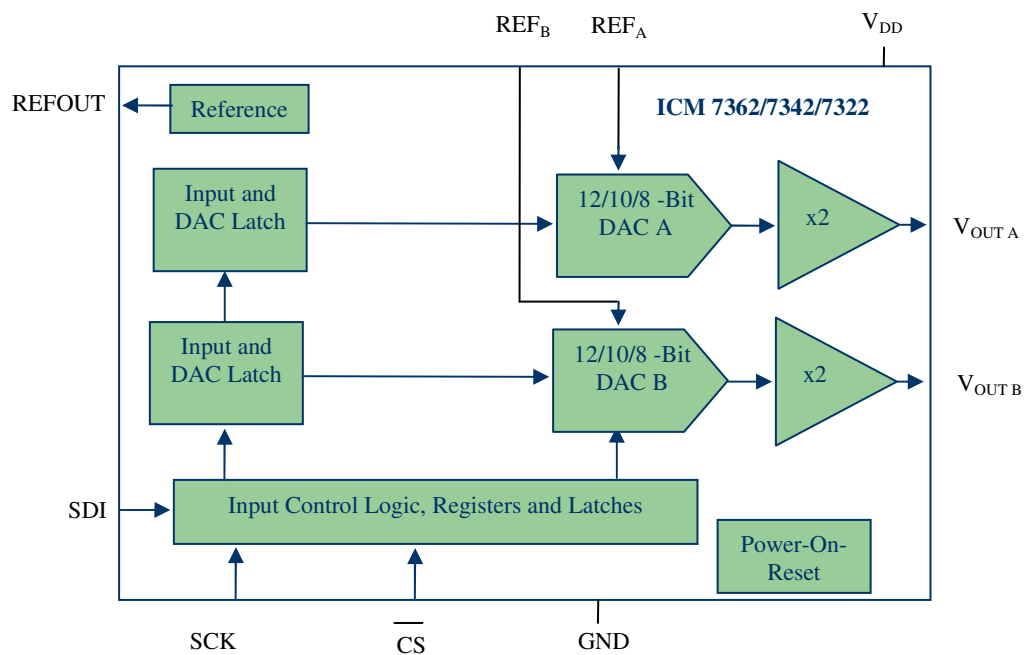

**PACKAGE**

10-Pin MSOP

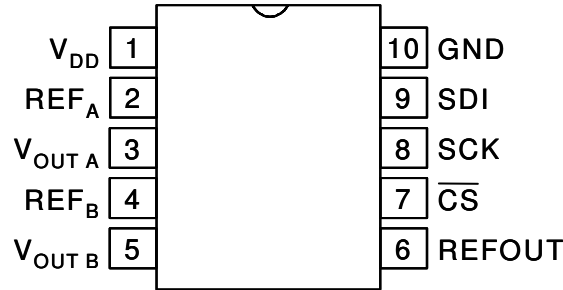

**PIN DESCRIPTION**

Pin No	Symbol	Description
1	V <sub>DD</sub>	Supply Voltage
2	REF <sub>A</sub>	DAC A Reference Input
3	V <sub>OUT A</sub>	DAC A Output
4	REF <sub>B</sub>	DAC B Reference Input
5	V <sub>OUT B</sub>	DAC B Output
6	REFOUT	Reference Output (1.25V)
7	$\overline{\text{CS}}$	Chip Select (TTL or CMOS)
8	SCK	Serial Clock Input (TTL or CMOS)
9	SDI	Serial Data Input (TTL or CMOS)
10	GND	Ground

**ABSOLUTE MAXIMUM RATING**

Symbol	Parameter	Value	Unit
V <sub>DD</sub>	Supply Voltage	-0.3 to 7.0	V
I <sub>IN</sub>	Input Current	+/- 25.0	mA
V <sub>IN</sub>	Digital Input Voltage (SCK, SDI, $\overline{\text{CS}}$ )	-0.3 to 7.0	V
V <sub>IN REF</sub>	Reference Input Voltage	-0.3 to 7.0	V
T <sub>STG</sub>	Storage Temperature	-65 to +150	°C
T <sub>SOL</sub>	Soldering Temperature	300	°C

**Note:** Stress greater than those listed under ABSOLUTE MAXIMUM RATINGS may cause permanent damage to the device. This is a stress rating only and functional operation of the device at these or any other conditions above those indicated in the operational sections of this specification is not implied. Exposure to absolute maximum rating conditions for extended periods may affect reliability.

**ORDERING INFORMATION**

Part	Temperature Range	Package
ICM7362	-40 °C to 85 °C	10-Pin MSOP
ICM7342	-40 °C to 85 °C	10-Pin MSOP
ICM7322	-40 °C to 85 °C	10-Pin MSOP

**DC ELECTRICAL CHARACTERISTICS**

( $V_{DD} = 2.7V$  to  $5.5V$ ,  $V_{REF IN} = 1.25V$ ;  $V_{OUT}$  unloaded; all specifications  $T_{MIN}$  to  $T_{MAX}$  unless otherwise noted)

Symbol	Parameter	Test Conditions	Min	Typ	Max	Unit
<b>DC PERFORMANCE</b>						
ICM7362						
N	Resolution		12			Bits
DNL	Differential Nonlinearity	(Notes 1 & 3)		0.4	+1.0	LSB
INL	Integral Nonlinearity	(Notes 1 & 3)		4.0	+12.0	LSB
ICM7342						
N	Resolution		10			Bits
DNL	Differential Nonlinearity	(Notes 1 & 3)		0.1	$\pm 1.0$	LSB
INL	Integral Nonlinearity	(Notes 1 & 3)		1.0	$\pm 3.0$	LSB
ICM7322						
N	Resolution		8			Bits
DNL	Differential Nonlinearity	(Notes 1 & 3)		0.05	$\pm 1.0$	LSB
INL	Integral Nonlinearity	(Notes 1 & 3)		0.25	$\pm 0.75$	LSB
GE	Gain Error				+0.5	% of FS
OE	Offset Error				+25	mV
<b>POWER REQUIREMENTS</b>						
$V_{DD}$	Supply Voltage		2.7		5.5	V
$I_{DD}$	Supply Current	(Note 4)		0.4	1.0	mA

Symbol	Parameter	Test Conditions	Min	Typ	Max	Unit
<b>OUTPUT CHARACTERISTICS</b>						
	Output Voltage Range	(Note 3)	0		$V_{DD}$	V
$V_{O SC}$	Short Circuit Current			60	150	mA
$R_{OUT}$	Amp Output Impedance	At Mid-scale (Note 2) At 0-scale (Note 2)		1.0 100	5.0 200	$\Omega$ $\Omega$
	Output Line Regulation	$V_{DD} = 2.7$ to $5.5$ V		0.4	3.0	mV/V
<b>LOGIC INPUTS</b>						
$V_{IH}$	Digital Input High	(Note 2)	2.4			V
$V_{IL}$	Digital Input Low	(Note 2)			0.8	V
	Digital Input Leakage				5	$\mu A$
<b>REFERENCE</b>						
$R_{IN}$	Reference Input Resistance		25	41	65	k $\Omega$
	Reference Input Range	(Note 2)	0.5		$V_{DD} - 1.5$	V
$V_{REF OUT}$	Reference Output		1.2	1.25	1.3	V
	Reference Output Line Regulation	$V_{DD} = 2.7$ to $5.5$ V		0.8	4.0	mV/V

**AC ELECTRICAL CHARACTERISTICS**

( $V_{DD} = 2.7V$  to  $5.5V$ ,  $V_{REF IN} = 1.25V$ ;  $V_{OUT}$  unloaded; all specifications  $T_{MIN}$  to  $T_{MAX}$  unless otherwise noted)

Symbol	Parameter	Test Conditions	Min	Typ	Max	Unit
SR	Slew Rate			2		V/ $\mu s$
	Settling Time	Full-scale settling		8		$\mu s$
	Mid-scale Transition Glitch Energy			40		nV-S

Note 1: Linearity is defined from code 64 to 4095 (ICM7362)  
Linearity is defined from code 16 to 1023 (ICM7342)  
Linearity is defined from code 4 to 255 (ICM7322)

Note 2: Guaranteed by design; not tested in production

Note 3: See Applications Information

Note 4: All digital inputs are either at GND or  $V_{DD}$

**TIMING CHARACTERISTICS**

( $V_{DD} = 2.7V$  to  $5.5V$ ; all specifications  $T_{MIN}$  to  $T_{MAX}$  unless otherwise noted)

Symbol	Parameter	Test Conditions	Min	Typ	Max	Unit
$t_1$	SCK Cycle Time	(Note 2)	30			ns
$t_2$	Data Setup Time	(Note 2)	10			ns
$t_3$	Data Hold Time	(Note 2)	10			ns
$t_4$	SCK Falling edge to $\overline{CS}$ Rising Edge	(Note 2)	0			ns
$t_5$	$\overline{CS}$ Falling Edge to SCK Rising Edge	(Note 2)	15			ns
$t_6$	$\overline{CS}$ Pulse Width	(Note 2)	20			ns

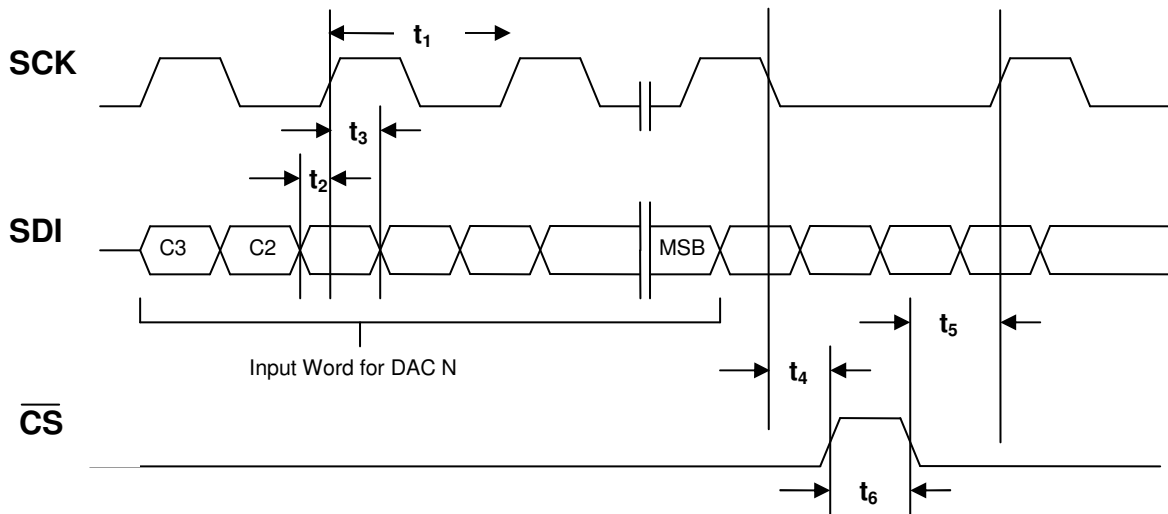

**Figure 1:** Serial Interface Timing Diagram

**CONTENTS OF INPUT SHIFT REGISTER**

**ICM7362 (12-Bit DAC)**

<b>MSB</b>													<b>LSB</b>			
C3	C2	C1	C0	D11	D10	D9	D8	D7	D6	D5	D4	D3	D2	D1	D0	

**Figure 2:** Contents of ICM7362 Input Shift Register

**ICM7342 (10-Bit DAC)**

<b>MSB</b>													<b>LSB</b>		
C3	C2	C1	C0	D9	D8	D7	D6	D5	D4	D3	D2	D1	D0	X	X

**Figure 3:** Contents of ICM7342 Input Shift Register

**ICM7322 (8-Bit DAC)**

<b>MSB</b>													<b>LSB</b>			
C3	C2	C1	C0	D7	D6	D5	D4	D3	D2	D1	D0	X	X	X	X	

**Figure 4:** Contents of ICM7322 Input Shift Register

C3	C2	C1	C0	DATA	DAC	FUNCTION
0	0	0	0	Data	A	Load Input Latch
0	0	0	1	Data	A	Update DAC
0	0	1	0	Data	A	Load Input Latch and Update DAC
0	0	1	1	Data	B	Load Input Latch
0	1	0	0	Data	B	Update DAC
0	1	0	1	Data	B	Load Input Latch and Update DAC
0	1	1	0	X	X	No Operation
0	1	1	1	X	X	No Operation
1	0	0	0	X	X	No Operation
1	0	0	1	X	X	No Operation
1	0	1	0	X	X	No Operation
1	0	1	1	X	X	No Operation
1	1	0	0	Data	A & B	Load Input Latch
1	1	0	1	Data	A & B	Update DAC
1	1	1	0	Data	A & B	Load Input Latch and Update DAC
1	1	1	1	X	X	No Operation

**Table 1:** Serial Interface Control Command

**DETAILED DESCRIPTION**

The ICM7362 is a 12-bit dual voltage output DAC. The ICM7342 is the 10-bit version of this family and the ICM7322 is the 8-bit version.

This family of DACs employs a resistor string architecture guaranteeing monotonic behavior. There is a 1.25V onboard reference and an operating supply range of 2.7V to 5.5V.

**Reference Input and Output**

Each DAC has its own reference input pin which can be driven from ground to  $V_{DD} - 1.5V$ . The input resistance on each of these pins is typically 41 k $\Omega$ . There is a gain of two in the output amplifiers which means they swing from ground at code 0 to  $2 \times V_{REF IN}$  at full-scale :

$$V_{out} = 2 \times (V_{REF IN} \times D) / 2^n$$

Where D=digital input (decimal) and n= number of bits, i.e. 12 for ICM7362, 10 for ICM7342 and 8 for ICM7322.

There is also an onboard band-gap reference on all these parts. This reference output is nominally 1.25V and is brought out to a separate pin, REFOUT and can be used to drive the reference input of the DACs. The outputs will nominally swing from 0 to 2.5V when using this reference.

**Output Amplifier**

Each DAC has its own output amplifier with a wide output voltage swing. The actual swing of the output amplifier will be limited by offset error and gain error. See the Applications Information Section for a more detailed discussion.

The amplifiers are configured in a gain of 2 with internal gain resistors of about 50 k $\Omega$ . The output swing will be from 0V to  $2 \times V_{REF IN}$  at full-scale.

The output amplifier can drive a load of 2.0 k $\Omega$  to  $V_{DD}$  or GND in parallel with a 500 pF load capacitance.

The output amplifier has a full-scale typical settling time of 8  $\mu s$  and it dissipates about 100  $\mu A$  with a 3V supply voltage.

**Serial Interface and Input Logic**

This dual DAC family uses a standard 3-wire connection compatible with SPI/QSPI interfaces. Data is loaded in 16-bit words which consist of 4 address and control bits (MSBs) followed by 12 bits of data (see table 1). The ICM7342 has the last two LSBs as don't cares and the ICM7322 has the last 4 LSBs as don't cares. Each DAC is double buffered with an input latch and a DAC latch.

All the digital inputs are CMOS/TTL compatible. The current dissipation of the device however, will be higher when the inputs are driven at TTL levels.

Data is clocked in on the rising edge of SCK which has a Schmitt trigger internally to allow for noise immunity on the SCK pin. This specially eases the use for opto-coupled interfaces.

The CS pin must be low when data is being clocked into the part. After the 16<sup>th</sup> clock pulse the CS pin must be pulled high (level-triggered) for the data to be transferred to an input bank of latches. The CS pin also disables the SCK pin internally when pulled high and the SCK pin must be low before the CS pin is pulled back low. As the CS pin is pulled high the shift register contents are transferred to

a bank of 16 latches. The 4 bit control word (C3~C0) is then decoded and the appropriate DAC is updated or loaded depending on the control word (see Table 1).

Each DAC has a double-buffered input with an input latch and a DAC latch. The DAC output will swing to its new value when data is loaded into the DAC latch. For each DAC, the user has three options: loading only the input latch, updating the DAC with data previously loaded into the input latch or loading the input latch and updating the DAC at the same time with a new code. The user also has the ability to perform this operation simultaneously for both DACs as shown in Table 1.

**Power-On Reset**

There is a power-on reset on board that will clear the contents of all the latches to all 0s on power-up and the DAC voltage outputs will go to ground.

**APPLICATIONS INFORMATION**

**Power Supply Bypassing and Layout Considerations**

As in any precision circuit, careful consideration has to be given to layout of the supply and ground. The return path from the GND to the supply ground should be short with low impedance. Using a ground plane would be ideal. The supply should have some bypassing on it. A 10  $\mu$ F tantalum capacitor in parallel with a 0.1  $\mu$ F ceramic with a low ESR can be used. Ideally these would be placed as close as possible to the device. Avoid crossing digital and analog signals, specially the reference, or running them close to each other.

**Output Swing Limitations**

The ideal rail-to-rail DAC would swing from GND to  $V_{DD}$  however, offset and gain error limit this ability. Figure 5 illustrates how a negative offset error will affect the output. The output will limit close to ground since this is single supply part, resulting in a dead-band area. As a larger input is loaded into the DAC the output will eventually rise

above ground. This is why the linearity is specified for a starting code greater than zero.

Figure 6 illustrates how a gain error or positive offset error will affect the output when it is close to  $V_{DD}$ . A positive gain error or positive offset will cause the output to be limited to the positive supply voltage resulting in a dead-band of codes close to full-scale. This can be avoided by using a reference voltage slightly less than  $0.5 \times V_{DD}$  ensuring that the full-scale of the DAC is always less than  $V_{DD}$ .

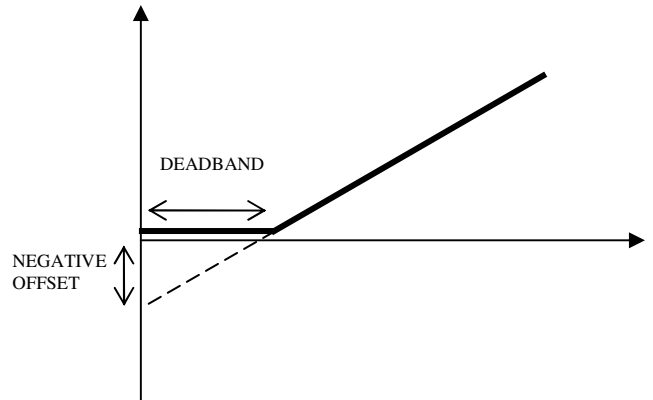

**Figure 5: Effect of Negative Offset**

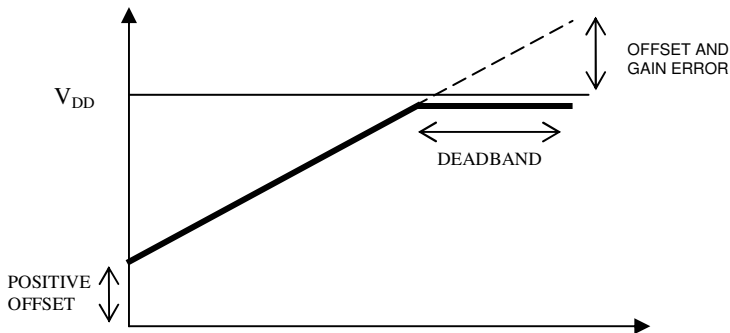

**Figure 6: Effect of Gain Error and Positive Offset**

**PACKAGE DIAGRAM**

**10-Pin MSOP Package**

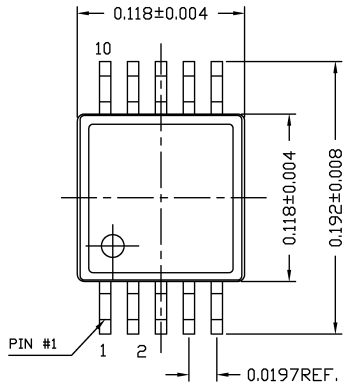

NOTE:

- 1) CONTROLLING DIMENSION: INCHES.
- 2) PACKAGE LENGTH DOES NOT INCLUDE MOLD FLASH, PROTRUSIONS OR GATE BURR.
- 3) PACKAGE WIDTH DOES NOT INCLUDE INTERLEAD FLASH OR PROTRUSIONS.

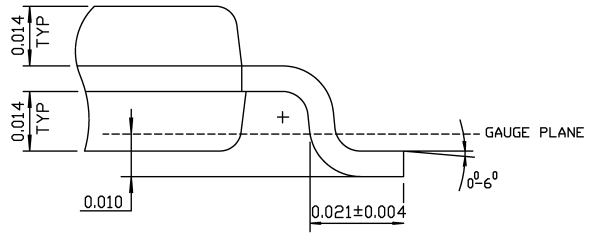

DETAIL "A" (3X)

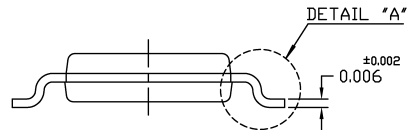
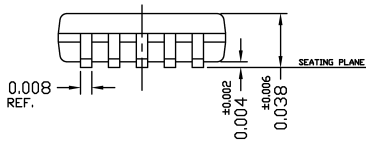

**ORDERING INFORMATION**

