



PRELIMINARY

SOLID STATE DEVICES, INC.

14830 Valley View Blvd * La Mirada, Ca 90638
Phone: (562) 404-7855 * Fax: (562) 404-1773

SVR1033N, P, E, & B

Designer's Data Sheet

3 Amp NEGATIVE ADJUSTABLE LINEAR VOLTAGE REGULATOR

Part Number /Ordering Information ^{1/}

SVR1033 N DB H

- Screening ^{2/}: _ = Not Screened
H = High Rel Level
K = Space Level
R = Radiation Tolerant
- Lead Bend: ^{3/} _ = Straight
DB = Down Bend
UB = Up Bend
- Package: N = TO-254
P = TO-254Z
E = MilPack I
B = MilPack II

FEATURES:

- 3A Output over -1.2 to -32V Voltage Range
- Internal Current, Power, and Thermal Limiting
- Eutectic Die Attach
- Replaces LT1033 Types
- Maximum Output Voltage Error of 1%
- Isolated Hermetically Sealed Power Package
- 150°C Operating Temperature
- Custom Lead Forming Available
- Ceramic Seal Package Available
- Class H or K (Space) Screening Available

MAXIMUM RATINGS	SYMBOL	VALUE	UNITS
Power Dissipation ^{4/}	P _D	Internally Limited, 30	W
Input to Output Voltage Differential	ΔV _{IN/OUT}	35	V
Maximum Current	I _{MAX}	3	A
Operating Junction Temperature	T _J	-55 TO +150	°C
Storage Temperature	T _{STG}	-65 TO +150	°C

TO-258 (N):	TO-259 (P):	MilPack I (E):	MilPack II (B):

PIN ASSIGNMENT

FUNCTION	PIN 1	PIN 2	PIN 3
Voltage Regulator	Adjust	Input	Output

NOTE: All specifications are subject to change without notification. SCD's for these devices should be reviewed by SSDI prior to release.

DATA SHEET #: SVR004A

SVR1033N, P, E, & B

PRELIMINARY



SOLID STATE DEVICES, INC.

14830 Valley View Blvd * La Mirada, Ca 90638
Phone: (562) 404-7855 * Fax: (562) 404-1773

Electrical Characteristics ^{4/}	t°	SYMBOL	MIN	TYP	MAX	UNITS
Reference Voltage $\Delta V = 5V, I_{OUT} = 5mA$ $5mA \leq I_{OUT} \leq I_{MAX}, 3V \leq \Delta V \leq 35V, P \leq P_{MAX}$	25	V_{REF}	-1.238	-1.250	-1.262	V
	*		-1.215	-1.250	-1.850	V
Line Regulation ^{5/} $3V \leq \Delta V \leq 35V$	25	$\frac{\Delta V_{OUT}}{\Delta V_{IN}}$	--	0.005	0.015	%/V
	*		--	0.02	0.04	%/V
Load Regulation ^{5/} ($10mA \leq I_{OUT} \leq I_{MAX}$)	25	$\frac{\Delta V_{OUT}}{\Delta I_{OUT}}$	--	10	50	mV
	25		--	0.2	1.0	%
	*		--	20	75	mV
	*		--	0.4	1.5	%
Thermal Regulation 10 msec Pulse	25		--	.002	.02	%/W
Ripple Rejection $V_{OUT} = -10V, f=120Hz$	25		56	66	--	dB
	25		70	80	--	dB
Adjust Pin Current	*	I_{ADJ}	--	65	100	μA
Adjust Pin Current Change $10mA \leq I_{OUT} \leq I_{MAX}$ $3V \leq \Delta V \leq 35V$	*	ΔI_{ADJ}	--	0.2	2	μA
	*		--	1.0	5	μA
Minimum Load Current $\Delta V \leq 35V$ $\Delta V \leq 10V$	25		--	2.5	5.0	mA
	25		--	1.2	3.0	mA
Current Limit $\Delta V \leq 10V_{DC}$ ^{5/} $\Delta V = 35V$	25	I_{SC}	3	4.3	6	A
	25		0.5	1.3	2.5	A
Temperature Stability $T_{MIN} \leq T \leq T_{MAX}$	*	$\frac{\Delta V_{OUT}}{\Delta T}$	--	0.3	1.5	%
Long Term Strability T = 1000 Hours	125	$\frac{\Delta V_{OUT}}{\Delta V_{time}}$	--	0.003	1.0	%
RMS Output Noise (% of V_{OUT}) 10 Hz $\leq f \leq$ 10 kHz	25	e_n	--	--	--	%
Thermal Resistance Junction to Case Package N and Z Package E and B		$R_{\theta JC}$	--		1.6	$^{\circ}C/W$
			--		1.2	$^{\circ}C/W$

NOTES:

- * Full Temperature Range
- ^{1/} For Ordering Information, Price, and Availability Contact Factory.
- ^{2/} Screening per MIL-STD-883.
- ^{3/} For Lead Bend Options Request Document # DSB-001 (Available for Download @ ssdi-power.com).
- ^{4/} Unless otherwise specified, these specifications apply: $\Delta V = 5V$ and $I_{OUT} = 5mA$. Power dissipation is internally limited. However, these specifications apply for power dissipation up to 30W, $I_{MAX} = 3A$.
- ^{5/} Testing is done using a pulsed low duty cycle technique.



PRELIMINARY

SVR1033N, P, E, & B

SOLID STATE DEVICES, INC.

14830 Valley View Blvd * La Mirada, Ca 90638
Phone: (562) 404-7855 * Fax: (562) 404-1773

TO-258 (N):

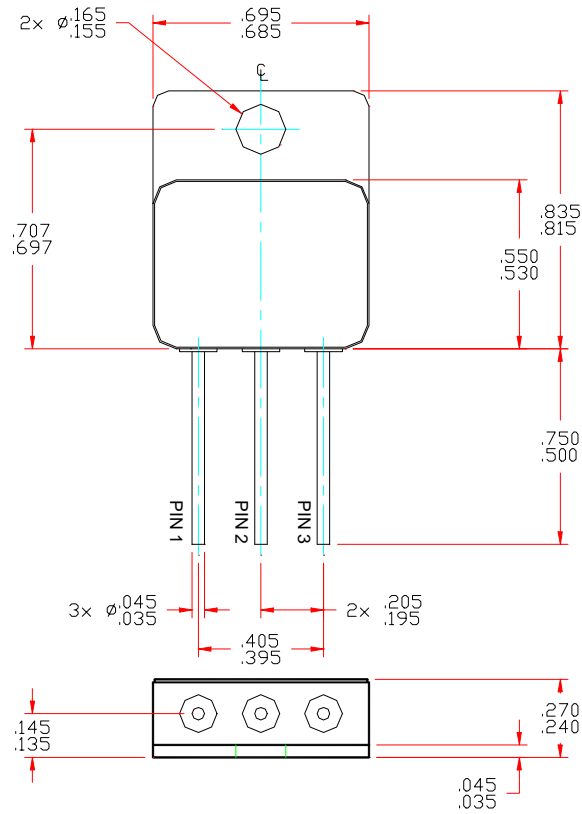

MilPack II (B):

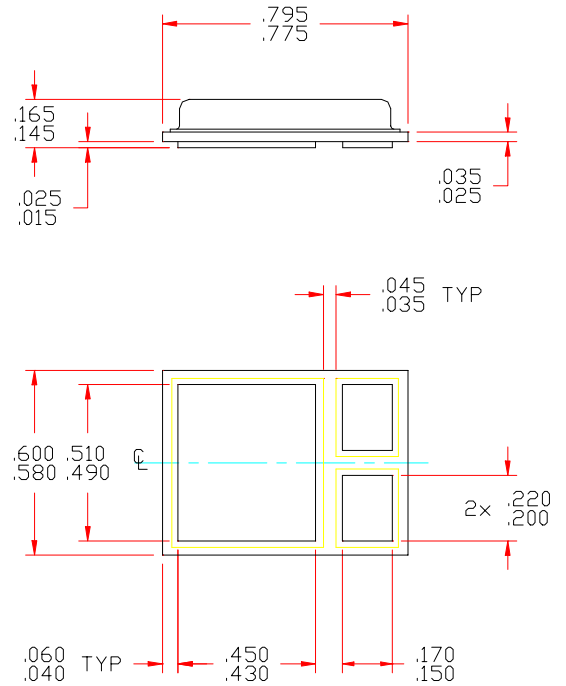

TO-259 (P)

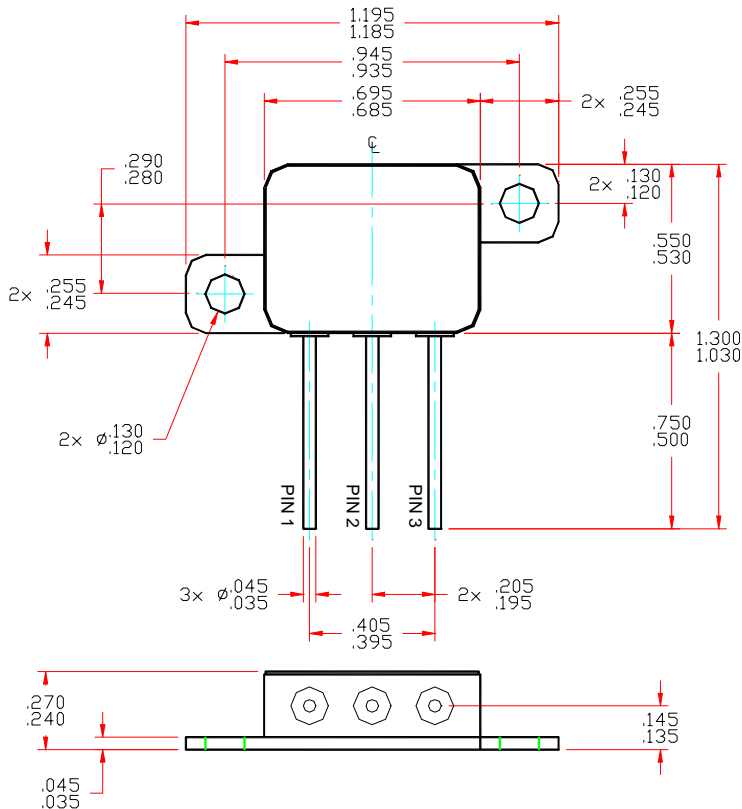

MilPack I (E):

