

DEPT	1
1	
2	
3	
4	3
5	
6	
7	
8	
9	
10	
11	
12	7
NC	
JZ	
DW	

PART NAME:

2 WAY MALE SCREW TERMINAL

PART NO: 3000M541B/

PART NO.	FINISH	COMMENTS
3000M541B	NONE	
3000M541BLT	NONE	LESS TAPPING
3000M541B-1	ELECTRO-TIN PLATE PCS 1002	
3000M541B-1LT	ELECTRO-TIN PLATE PCS 1002	MAKE FROM 3000M541BLT BY PLATING

U

NOTES

- ALL PORTIONS OF TAB SHOWN SHALL BE FLAT AND FREE OF BURRS OR RAISED PLATEAUS, EXCEPT THAT THERE MAY BE, IN AN AREA .050 SURROUNDING THE DETENT, A RAISED PLATEAU OVER THE STOCK THICKNESS OF .001 PER SIDE.
- DETENT SHALL BE LOCATED WITHIN .005 OF THE TAB CENTERLINE.
- MALE TAB MUST CONFORM TO NEMA DC2-19XX.
- TO ACCEPT .250 X .032 FEMALE RECEPTACLE.

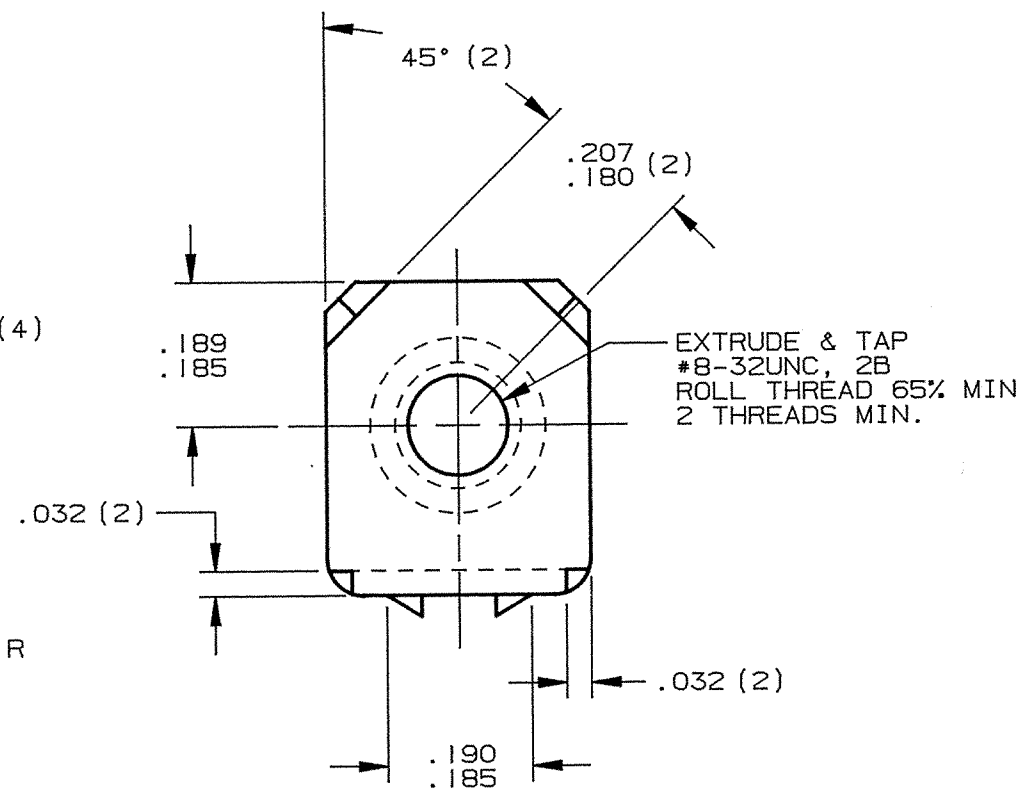
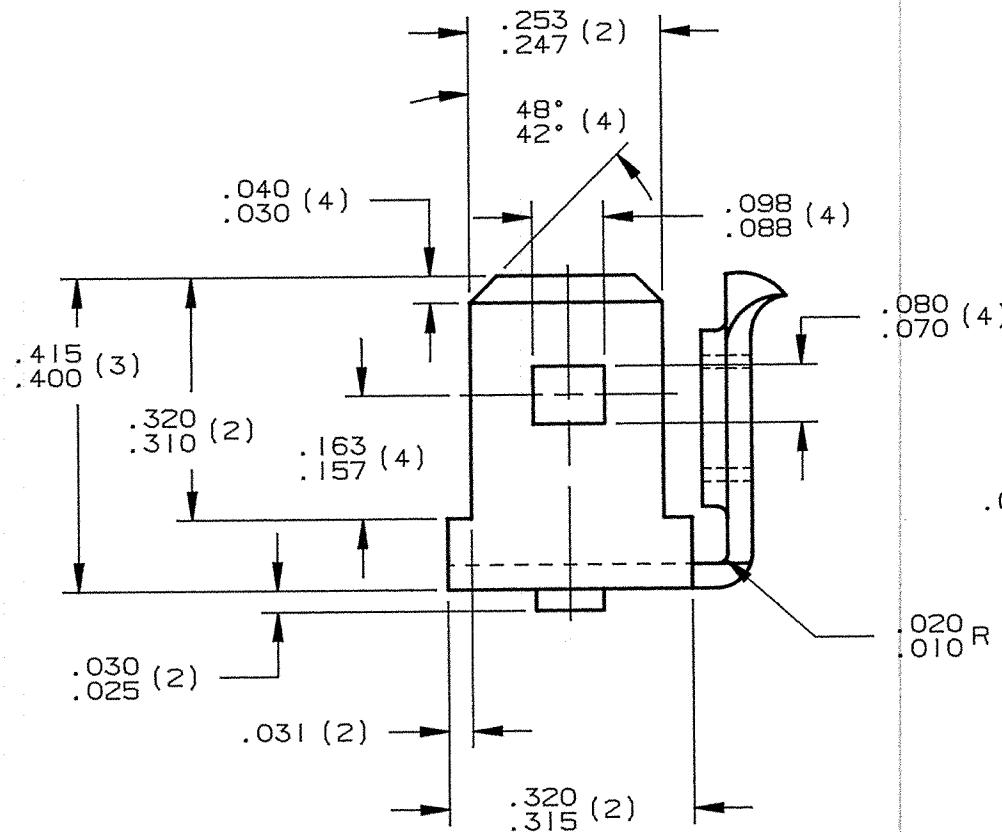
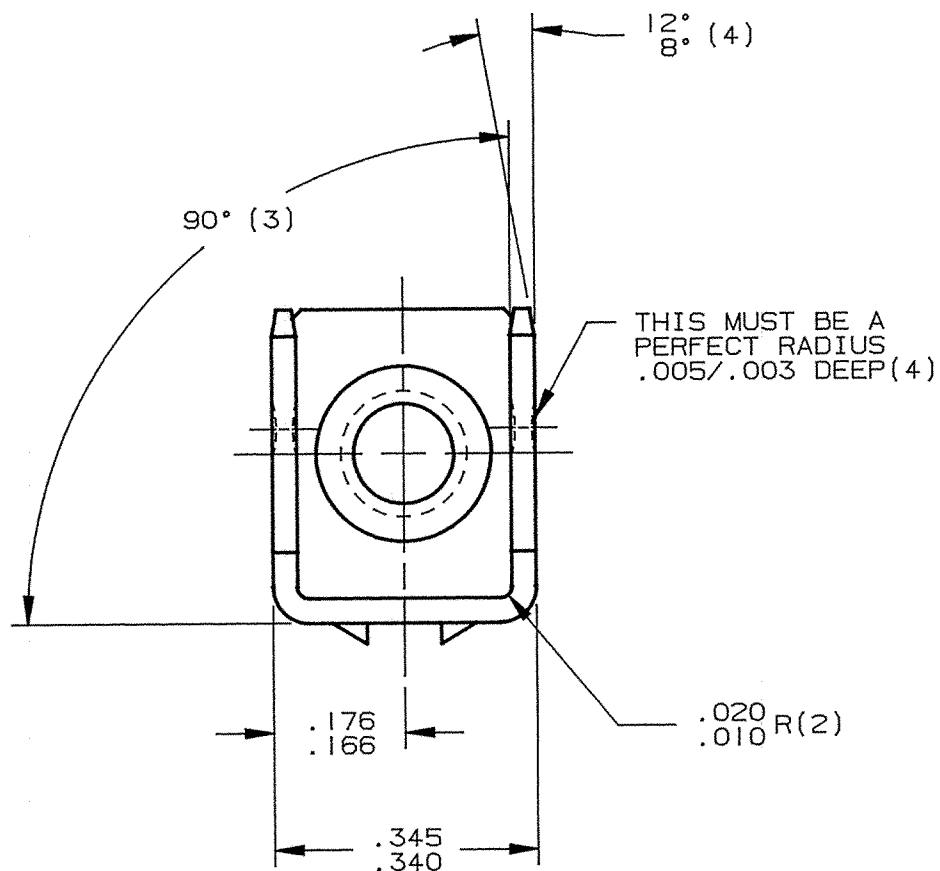
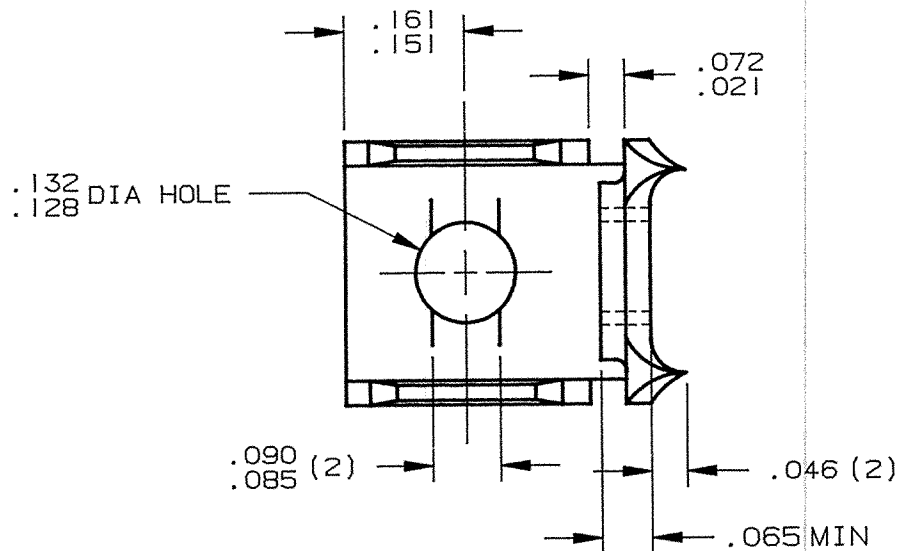

ARK-LES UNCONTROLLED

				PROD. REL.	85563	12/26/63	HK	TOLERANCES UNLESS OTHERWISE SPECIFIED:		
				QUOTE REL.	74324	10/29/63	TB	DECIMALS ±.010	METRIC ±0.25mm	ANGLES ±1°
				DR:	B J CARUTHERS	9/23/94		MATERIAL: .032±.001 THK BRASS C26000, 1/2 HARD R30T 56.5-68.0		
				CHK'D:	R.W.S.	4-11-95		FINISH: SEE TABLE		
				APP:	COR	4-13-95		PART NO: 3000M541B/		
				SUPERCEDES DWG. DATED:	1/26/84					
REV.	DESCRIPTION	DATE	DR.	SCALE: 4:1	CAD NO: BTP0024					
U	REVISED PER ECR #10488	4/5/95	RT							
T	REVISED & REDRAWN PER ECR #10277	9/23/94	BJC							

ORIGINAL