

DIAMONDBACK Series Programmable Multi-Channel Solid State Power Controllers



The Diamondback Series of Programmable Multi-Channel Solid State Power Controllers (SSPC) is a microcontroller-based, COTS Solid State Power Controller board designed for 28VDC applications. Each channel of the Diamondback has software-programmable current ratings and can operate grouped with other channels to support loads up to 150A. The board has integrated current, temperature and voltage sensing and no derating over temperature. Parameter measurements, system status information and control commands are issued over a serial communications interface.

Features:

- 16 electrically-protected channels
- Programmable ratings from 0.25A to 25A
- Parallel channel capability up to 150A
- Total current capability of up to 160A
- Max power dissipation less than 20W
- True I²t and thermal memory protection
- Normal and SensWide™ instant trip
- Trip-free reset circuit
- Current, temperature, voltage readings
- Hi accuracy over temperature range
- Controlled turn-on/off to reduce EMC
- Trip disable and maintenance modes
- Power-up and continuous built-in-test
- Optically isolated input and outputs
- Isolated electrical control circuit
- 5VDC auxiliary power option
- Conduction cooled board
- -55°C to 85°C operating temperature

Benefits:

Sensitron's SSPC technology and products combine the functionalities of electro-mechanical breakers, solid state relays, and system monitors, thereby providing the following benefits to our customers:

- Electrical load protection and monitoring - current, voltage and temperature measurements
- Operational improvements by allowing for diagnostics, prognostics and condition-based maintenance
- Life cycle cost savings and reduced cost of ownership
- Increased radius of operation through power budgeting and load shedding
- Crew offloading and network-controlled intelligent load management

Application Areas:

Sensitron's SSPC products are ideal for use in Power Management applications in the following markets:

- Military Ground Vehicles
- Unmanned Aerial Vehicles
- Marine Vessels
- Test & Industrial Equipment
- Communication and Command Centers
- Energy Exploration Equipment
- Off Highway and Heavy Duty Vehicles
- Medical Emergency Vehicles

Product Brief
PB5114, Rev -

CURRENT PROTECTION

Similarly to the traditional electromechanical circuit breakers, the DIAMONDBACK protects electrical circuits by closely controlling the I^2t factor.

CHANNEL PARALLELING

Multiple individual channels can be paralleled in order handle large current loads. The new current rating is calculated as the sum of the individual channel ratings. To use channels in parallel, simply tie the channels' load pins together, put the board in maintenance mode, and program the required parallel combination.

HEALTH MONITORING

DIAMONDBACK Solid State Power Controller provides current, voltage and temperature measurements. This information can be used to monitor electrical loads and perform tasks such as diagnostics, prognostics and condition-based maintenance.

BLOCK DIAGRAM

DIAMONDBACK's architecture is comprised of high side switches controlled by a central microprocessor. The switching blocks are responsible for the control of individual channels. The processor performs all necessary measurements, data processing, and communicates to the user's application through a CAN communications interface.

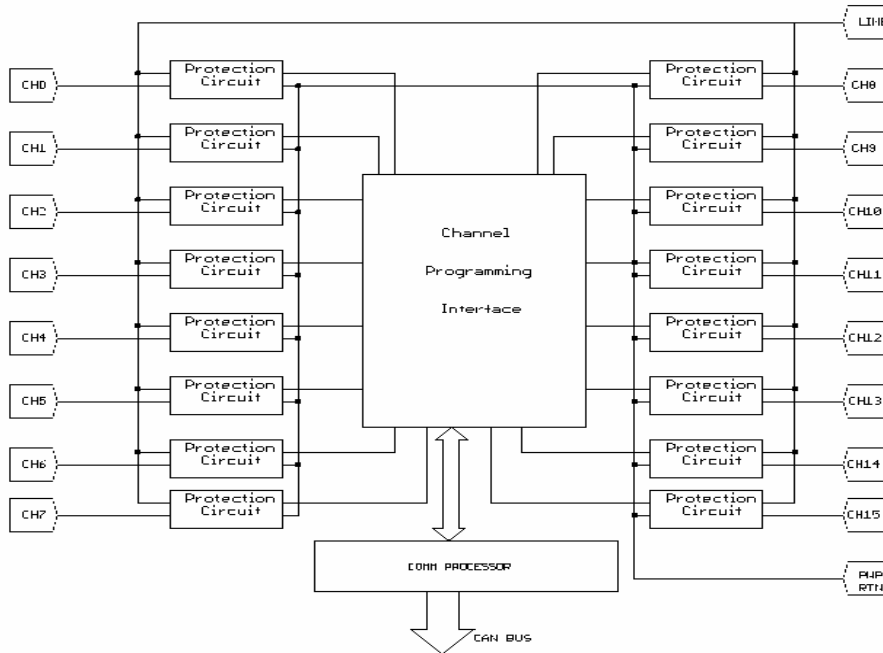

Figure 1 – Block Diagram

CAN COMMUNICATIONS

All communications between the Diamondback and the controller is conducted via a J1939 compliant CAN communications interface. Diamondback only responds to the user's commands, however, user's software is not required to operate the Diamondback Series products. Communications interface commands are defined by Sensitron's Interface Communications Document (ICD). Please contact us for a copy of this document.

Product Brief
PB5114, Rev -

I/O DEFINITIONS

Control & Status (TTL/CMOS Compatible)	
BIAS (V_{CC})	5.0V DC Nominal, 7.0V DC Absolute Maximum 4.5V to 5.5 VDC
BIAS (V_{CC}) Current	210mA typ (TBD)
BIT* Output	V_{oh} =3.7V, min, at I_{oh} =-20mA V_{ol} =0.4V, max, at I_{ol} =20mA
MAINTENANCE MODE and TRIP DISABLE Inputs V_{T+} (Positive-going input threshold voltage) V_{T-} (Negative-going input threshold voltage) ΔV_T Hysteresis (V_{T+} V_{T-})	2.0V, min, 3.5V, max 1.2V, min, 2.3V, max 0.6V, min, 1.4V, max
CAN¹	
Driver Output Voltage – CANH (Dominant)	2.75V, min; 3.5V, typ; 4.5V, max
Driver Output Voltage – CANL (Dominant)	0.5V, min; 2V, max
Driver Output Voltage – CANH (Recessive)	1.5V, min; 2.5V, typ; 3V, max
Driver Output Voltage – CANL (Recessive)	1.5V, min; 2.5V, typ; 3V, max
Driver Differential Output Voltage (Dominant)	1.2V, min; 2V, typ; 3.1V, max
Driver Differential Output Voltage (Recessive)	-120mV, min; 12mV, Max
Driver Differential Output Voltage Rise/Fall Time	100nS to 250nS depending on Baud Rate
Receiver Positive-going input threshold	750mV, typ; 900mV, max
Receiver Negative-going input threshold	500mV, min; 650mV, typ
Receiver Input Hysteresis	100mV, typ
Receiver Input Resistance	40k Ω , min; 100k Ω , max
ESD – Human body model	+14kV, typ
Input/Line Voltage	
Input Voltage – Continuous – Transient	0 to 70V DC, 90V DC Abs Maximum +600V or -600V Spike (< 10 μ S)
Max Output Voltage of OFF Channel	1.2V typ @ V_{LINE} = 28VDC 3.3V max @ V_{LINE} = 28VDC 4.3V max @ V_{LINE} = 45VDC
Max current without tripping	145% of the programmed current rating
Min current for guaranteed tripping	115% of the programmed current rating

Table 1 - Electrical Characteristics

APPLICATION SUPPORT

Sensitron's Graphical User Interface provides a quick way to interact with the Diamondback board. This PC-based program is designed for lab use and enables the user to evaluate the board. The GUI sends the commands to the board to perform tasks such as channel turn on/off, measurement readings, channel paralleling, etc.

Please contact the factory to obtain a copy of this program.

COMPLIANT DOCUMENTS & STANDARDS

MIL-STD-1275D	Characteristics of 28 Volt DC Electrical Systems in Military Vehicles
MIL-STD-704F	Aircraft Electrical Power Characteristics
MIL-STD-217F, Notice 2	Reliability Prediction of Electronic Equipment

Product Brief
PB5114, Rev -

OUTLINE DRAWING

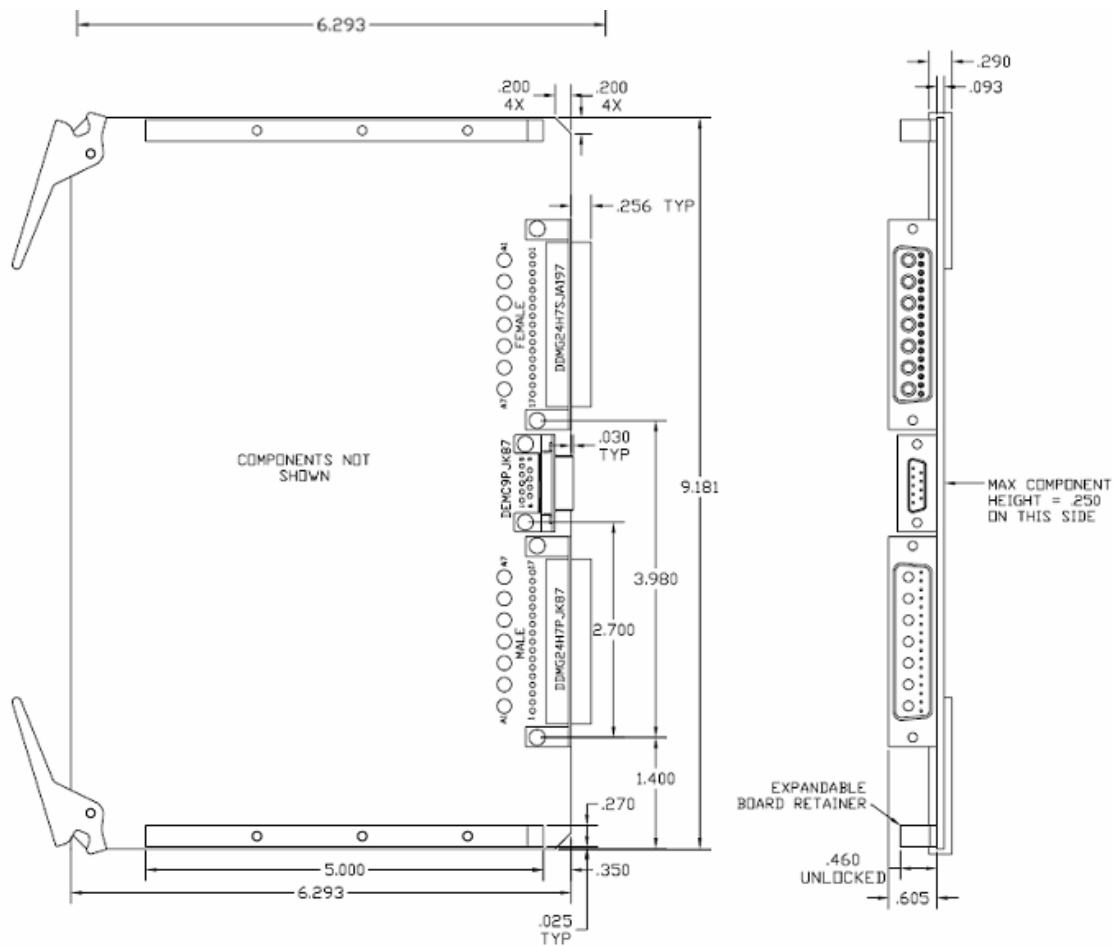

PART NUMBER ORDERING INFORMATION:
Reference Diamondback Series for ordering.

DISCLAIMER:

- 1- The information given herein, including the specifications and dimensions, is subject to change without prior notice to improve product characteristics. Before ordering, purchasers are advised to contact the Sensitron Semiconductor sales department for the latest version of the datasheet(s).
- 2- In cases where extremely high reliability is required (such as use in nuclear power control, aerospace and aviation, traffic equipment, medical equipment, and safety equipment), safety should be ensured by using semiconductor devices that feature assured safety or by means of users' fail-safe precautions or other arrangement.
- 3- In no event shall Sensitron Semiconductor be liable for any damages that may result from an accident or any other cause during operation of the user's units according to the datasheet(s). Sensitron Semiconductor assumes no responsibility for any intellectual property claims or any other problems that may result from applications of information, products or circuits described in the datasheets.
- 4- In no event shall Sensitron Semiconductor be liable for any failure in a semiconductor device or any secondary damage resulting from use at a value exceeding the absolute maximum rating.
- 5- No license is granted by the datasheet(s) under any patents or other rights of any third party or Sensitron Semiconductor.
- 6- The datasheet(s) may not be reproduced or duplicated, in any form, in whole or part, without the expressed written permission of Sensitron Semiconductor.
- 7- The products (technologies) described in the datasheet(s) are not to be provided to any party whose purpose in their application will hinder maintenance of international peace and safety nor are they to be applied to that purpose by their direct purchasers or any third party. When exporting these products (technologies), the necessary procedures are to be taken in accordance with related laws and regulations.