

TECHNICAL DATA
DATA SHEET 4197, REV. -**HERMETIC POWER MOSFET
N-CHANNEL****FEATURES:**

- 200 Volt, 80A, 36 milliohm
- Isolated Hermetic Metal Package
- Fast intrinsic Rectifier
- Low package inductance-easy to drive and protect
- Add suffix S for S-100 screening

MAXIMUM RATINGSALL RATINGS ARE AT $T_C = 25^\circ\text{C}$ UNLESS OTHERWISE SPECIFIED.

RATING	SYMBOL	MIN.	TYP.	MAX.	UNITS
GATE TO SOURCE VOLTAGE	V_{GS}	-	-	± 20	Volts
ON-STATE DRAIN CURRENT @ $T_C = 25^\circ\text{C}$	$I_{D(on)}$	-	-	80	Amps
PULSED DRAIN CURRENT @ $T_C = 25^\circ\text{C}$	I_{DM}	-	-	300	Amps
OPERATING AND STORAGE TEMPERATURE	T_{OP}/T_{STG}	-55	-	+150	$^\circ\text{C}$
THERMAL RESISTANCE, JUNCTION TO CASE	R_{thJC}	-	-	0.25	$^\circ\text{C}/\text{W}$
TOTAL DEVICE DISSIPATION @ $T_C = 25^\circ\text{C}$	P_D	-	-	500	Watts

ELECTRICAL CHARACTERISTICS

RATING	SYMBOL	MIN.	TYP.	MAX.	UNITS
DRAIN TO SOURCE BREAKDOWN VOLTAGE $V_{GS} = 0\text{V}, I_D = 250\ \mu\text{A}$	BV_{DSS}	200	-	-	Volts
STATIC DRAIN TO SOURCE ON STATE RESISTANCE $V_{GS} = 10\text{V}, I_D = 40\text{A}$	$R_{DS(ON)}$	-	-	0.036	Ω
GATE THRESHOLD VOLTAGE $V_{DS} = V_{GS}, I_D = 250\ \mu\text{A}$	$V_{GS(th)}$	2.0	-	4.0	Volts
FORWARD TRANSCONDUCTANCE $V_{DS} = 10\text{V}, I_D = 40\text{A}$	g_{fs}	35	45	-	$\text{S}(1/\Omega)$
ZERO GATE VOLTAGE DRAIN CURRENT $V_{DS} = 0.8 \times \text{Max. Rating}, V_{GS} = 0\text{V}$ $V_{DS} = 0.8 \times \text{Max. Rating}, V_{GS} = 0\text{V}, T_J = 125^\circ\text{C}$	I_{DSS}	-	-	50 1.0	μA mA
GATE TO SOURCE LEAKAGE FORWARD $V_{GS} = 20\text{V}$	I_{GSS}	-	-	100	nA
GATE TO SOURCE LEAKAGE REVERSE $V_{GS} = -20\text{V}$				-100	
TURN ON DELAY TIME RISE TIME TURN OFF DELAY TIME FALL TIME $V_{DS} = 100\text{V}, I_D = 40\text{A}, R_G = 2.0\ \Omega, V_{GS} = 10\text{V}$	$t_{d(ON)}$ t_r $t_{d(OFF)}$ t_f	-	26 50 75 20	-	nsec
DIODE FORWARD VOLTAGE $T_C = 25^\circ\text{C}, I_S = 80\text{A}, V_{GS} = 0\text{V}$	V_{SD}	-	-	1.5	Volts
REVERSE RECOVERY TIME $I_F = 80\text{A}, -di/dt = 100\text{A}/\mu\text{sec}, V_R = 100\text{V}$	t_{rr}	-	-	200	nsec
INPUT CAPACITANCE OUTPUT CAPACITANCE REVERSE TRANSFER CAPACITANCE $V_{GS} = 0\text{V}$ $V_{DS} = 25\text{V}$ $f = 1.0\text{MHz}$	C_{iss} C_{oss} C_{rss}	-	4600 1100 500	-	pF

SENSITRON

**TECHNICAL DATA
DATA SHEET 4197, Rev -**

MECHANICAL DIMENSIONS: in Inches / mm

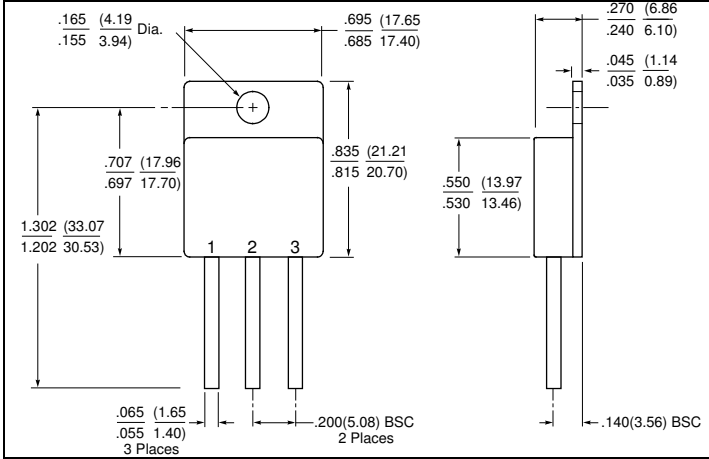

TO-258

PINOUT TABLE

DEVICE TYPE	PIN 1	PIN 2	PIN 3
MOSFET IN A TO-258 PACKAGE	DRAIN	SOURCE	GATE

TECHNICAL DATA

DISCLAIMER:

- 1- The information given herein, including the specifications and dimensions, is subject to change without prior notice to improve product characteristics. Before ordering, purchasers are advised to contact the Sensitron Semiconductor sales department for the latest version of the datasheet(s).
- 2- In cases where extremely high reliability is required (such as use in nuclear power control, aerospace and aviation, traffic equipment, medical equipment, and safety equipment), safety should be ensured by using semiconductor devices that feature assured safety or by means of users' fail-safe precautions or other arrangement.
- 3- In no event shall Sensitron Semiconductor be liable for any damages that may result from an accident or any other cause during operation of the user's units according to the datasheet(s). Sensitron Semiconductor assumes no responsibility for any intellectual property claims or any other problems that may result from applications of information, products or circuits described in the datasheets.
- 4- In no event shall Sensitron Semiconductor be liable for any failure in a semiconductor device or any secondary damage resulting from use at a value exceeding the absolute maximum rating.
- 5- No license is granted by the datasheet(s) under any patents or other rights of any third party or Sensitron Semiconductor.
- 6- The datasheet(s) may not be reproduced or duplicated, in any form, in whole or part, without the expressed written permission of Sensitron Semiconductor.
- 7- The products (technologies) described in the datasheet(s) are not to be provided to any party whose purpose in their application will hinder maintenance of international peace and safety nor are they to be applied to that purpose by their direct purchasers or any third party. When exporting these products (technologies), the necessary procedures are to be taken in accordance with related laws and regulations.