

TECHNICAL DATA
DATA SHEET 5375, REV. -

**THREE PHASE FULL WAVE BRIDGE RECTIFIER ASSEMBLY
WITH AISiC TECHNOLOGY**

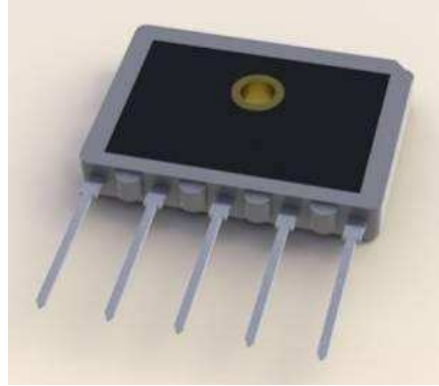

DESCRIPTION: 1200 V, 45 A, 500 Nanosecond THREE PHASE BRIDGE RECTIFIER ASSEMBLY
MAX. RATINGS / ELECTRICAL CHARACTERISTICS All ratings are at $T_A = 25^\circ\text{C}$ unless otherwise specified.

RATING	CONDITIONS	MIN	TYP	MAX	UNIT
Peak Inverse Voltage (PIV)	-	-	-	1200	Vdc
Average DC Output Current (I_o)	$T_C = 55^\circ\text{C}$ $T_C = 100^\circ\text{C}$ $T_C = 125^\circ\text{C}$	-	-	45 28 16	A
Average DC Output Current Ambient Temp. (no heat sink) (I_o)	$T_A = 25^\circ\text{C}$ $T_A = 55^\circ\text{C}$ $T_A = 100^\circ\text{C}$	-	-	8.0 5.0 2.5	A
Peak Single Cycle Surge Current (I_{FSM})	$t_p = 8.3$ ms Single Half Cycle Sine Wave	-	-	300	A(pk)
Operating and Storage Temp. (T_{op} & T_{stg})	-	-55	-	+150	$^\circ\text{C}$
Maximum Forward Voltage (V_f) (300 μsec pulse, duty cycle < 2%)	$I_f = 9\text{A}$ $I_f = 45\text{A}$	-	-	1.40 1.90	V
Maximum Instantaneous Reverse Current At Rated PIV	$T_A = 25^\circ\text{C}$ $T_A = 100^\circ\text{C}$	-	-	50 500	μA
Reverse Recovery Time (t_{rr})	$I_f = 0.5\text{A}$, $I_r = 1.0\text{A}$, $I_{rr} =$ 0.25A	-	-	500	nsec
Thermal Resistance (θ_{JL}) Per Leg	-	-	-	2.8	$^\circ\text{C/W}$
Weight	-	-	-	15	gms

Note: Add a suffix **S** to the part number for **JAN-S Level Screening**.

SENSITRON
TECHNICAL DATA
DATA SHEET 5375, REV. -

MECHANICAL DIMENSIONS: In Inches

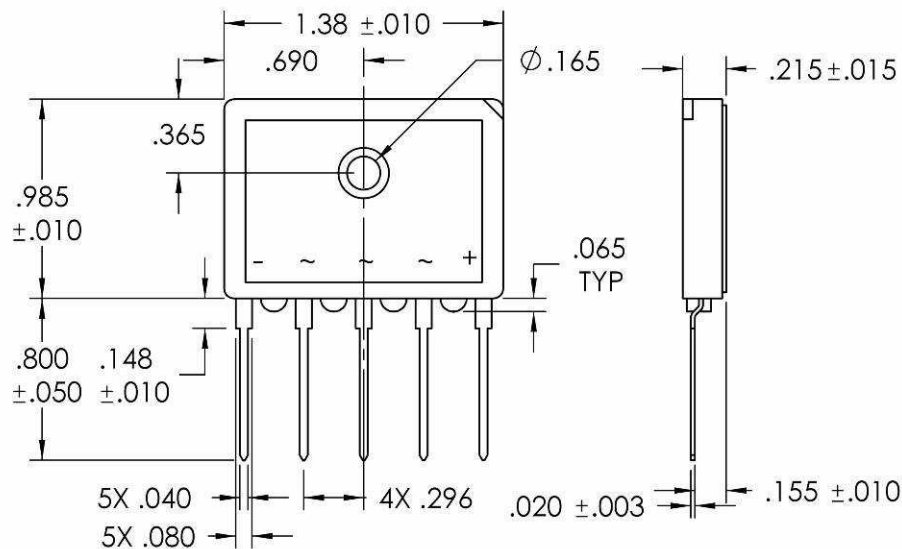

TOLERANCE = $\pm .005$ UNLESS OTHERWISE NOTED

DISCLAIMER:

- 1- The information given herein, including the specifications and dimensions, is subject to change without prior notice to improve product characteristics. Before ordering, purchasers are advised to contact the Sensitron Semiconductor sales department for the latest version of the datasheet(s).
- 2- In cases where extremely high reliability is required (such as use in nuclear power control, aerospace and aviation, traffic equipment, medical equipment, and safety equipment), safety should be ensured by using semiconductor devices that feature assured safety or by means of users' fail-safe precautions or other arrangement.
- 3- In no event shall Sensitron Semiconductor be liable for any damages that may result from an accident or any other cause during operation of the user's units according to the datasheet(s). Sensitron Semiconductor assumes no responsibility for any intellectual property claims or any other problems that may result from applications of information, products or circuits described in the datasheets.
- 4- In no event shall Sensitron Semiconductor be liable for any failure in a semiconductor device or any secondary damage resulting from use at a value exceeding the absolute maximum rating.
- 5- No license is granted by the datasheet(s) under any patents or other rights of any third party or Sensitron Semiconductor.
- 6- The datasheet(s) may not be reproduced or duplicated, in any form, in whole or part, without the expressed written permission of Sensitron Semiconductor.
- 7- The products (technologies) described in the datasheet(s) are not to be provided to any party whose purpose in their application will hinder maintenance of international peace and safety nor are they to be applied to that purpose by their direct purchasers or any third party. When exporting these products (technologies), the necessary procedures are to be taken in accordance with related laws and regulations.