

# LG248

The LG248 photointerrupter combine high output GaAs IRED with Photo IC. The sensor makes possible easy development of object detecting systems with high performance, high reliability and small equipment size.

LG248L1 : High level output at shielding

LG248D1 : Low level output at shielding

## FEATURES

- Connector type AMP ( JAPAN ), Ltd.
- GAP : 5.0mm
- Snap- in mount
- 3 kinds of mounting plate thicknesses : 1.0mm, 1.2mm, 1.6mm

## APPLI CATIONS

- Copiers
- Printers
- Auto stampers
- Ticket vending machines

## MAXIMUM RATINGS

(Ta=25°C)

Item	Symbol	Rating	Unit
Supply voltage	V <sub>cc</sub>	8	V
Output voltage	V <sub>o</sub>	12	V
Low level output current	I <sub>oL</sub>	16	mA
Power dissipation	P	100	mW
Operating temp.*1 *2	Topr.	-25~+75	°C
Storage temp.*1 *2	Tstg	-30~+85	°C

\*1. The connector shall be inserted or pulled out at normal temperature.

\*2. No icebound or dew

## DI MENSIONS

(Unit : mm)

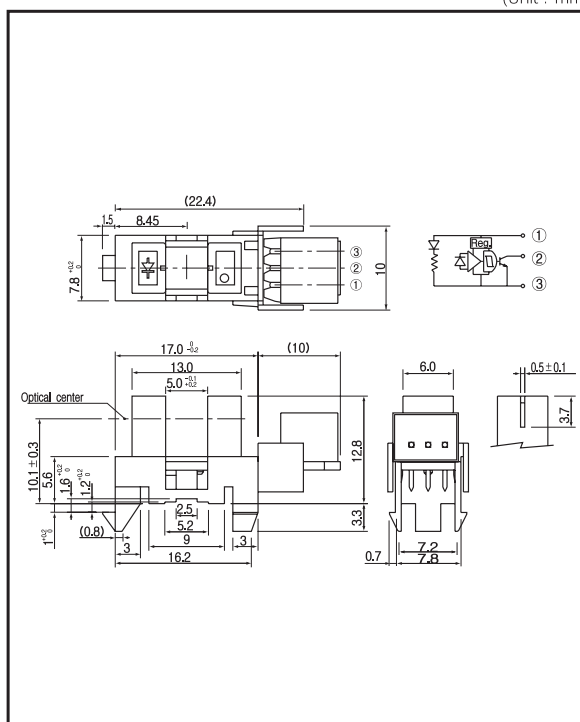

## ELECTRO-OPTICAL CHARACTERISTICS

(Ta=25°C)

Item	Symbol	Conditions	Min.	Typ.	Max.	Unit.
Operating supply voltage rang	V <sub>cc</sub>		4.5		5.5	V
Low level output voltage	V <sub>oL</sub>	V <sub>cc</sub> = 5V, I <sub>oL</sub> = 16mA, (Shading)		0.3	0.4	V
High level output voltage	V <sub>oH</sub>	V <sub>cc</sub> = 5V, R <sub>L</sub> = 10k Ω, (Non- shading)	4.5			V
Low level supply current	I <sub>ccL</sub>	V <sub>cc</sub> = 5V, (Shading)		20	35	mA
High level supply current	I <sub>ccH</sub>	V <sub>cc</sub> = 5V, (Non- shading)		20	35	mA
Frequency	f	V <sub>cc</sub> = 5V, R <sub>L</sub> = 10k Ω	3000			Hz

Photointerrupters(Transmissive)

**LG - 248**

**Power dissipation Vs. Ambient temperature**

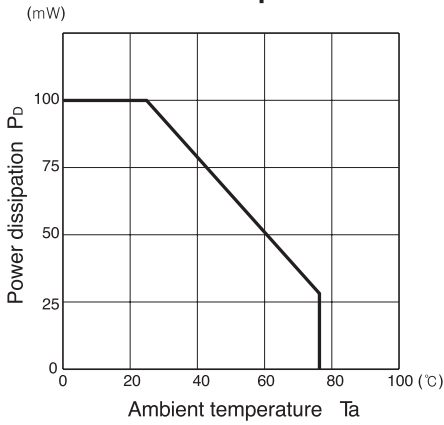

**Forward current Vs. Forward voltage**

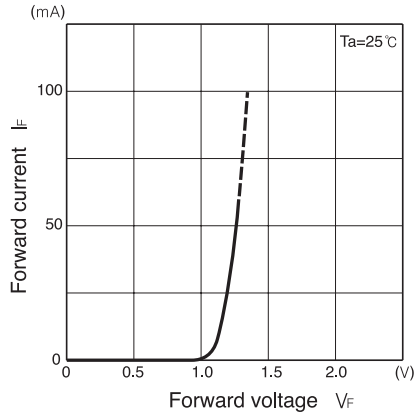

**Low level output voltage Vs. Low level output current**

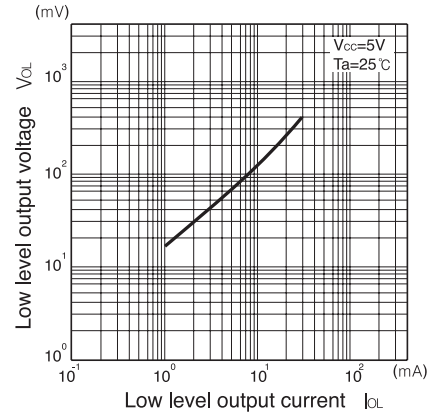

**Low level output voltage Vs. Ambient temperature**

