

SPECIFICATION

ISSUED DATE : 2012.12.13

DOCUMENT NO : KP5450F00E6F

CUSTOMER :

DESCRIPTION : 5450 6 Pin Top View Full Color LED

MODEL NO. : KP5450F00E6F

[AUK CORP.]

ISSUE DEPT.			PRODUCTION		Q/A	
ISSUE	REVIEW	APPR'L	REVIEW	APPR'L	REVIEW	APPR'L

[CUSTOMER APPROVAL]

ISSUE	REVIEW					

[REVISION]

NO	DATE	REVISION ITEMS	ISSUED BY	APPR'D BY
0	2012.11.13	Spec. Update	K.Lim	J.S.HEO

■ Contents

- ◆ PL
 - 1 . Descriptions
 - 2 . Features
 - 3 . Applications
 - 4 . Outline Dimensions and Material Descriptions
 - 5 . Absolute Maximums
 - 6 . Elector-Optical Characteristics
 - 7 . Ranks
 - 8 . Part Numbering
 - 9 . Characteristic Graphs
 - 10 . Reliability Test
 - 11 . Recommended Soldering Pattern
 - 12 . Reflow Soldering Profile
 - 13 . Manual Soldering Conditions
 - 14 . Tape and Reel Specifications
 - 15 . Packing Specifications
 - 16 . Label
 - 17 . Cautions

◆ PL

This specification sheets include the contents under the copyright of KODENSHI AUK ('AUK'). Please keep them with reasonable care as important information.

Please don't reproduce or cause anyone reproduce them without AUK's consent.

AUK takes no responsibility for damage caused by improper use of the devices which does not meet the conditions and absolute maximum ratings to be used specified in the relevant specification sheet.

Please obey the instructions mentioned below for actual use of this device.

① This device is designed for general electronic equipment.

Main use of this device are as follows;

- * Computer * OA equipment * Telecommunication equipment(Terminal)
- * Measuring instrument * Machine tool * Industrial robot
- * AV equipment * Home appliance,etc.

② Please take proper steps in order to maintain reliability and safety, in case this device is used for the uses mentioned below which require high reliability.

- * Unit concerning control and safety of a vehicle (air plane,train,automobile, etc.)
- * Traffic signal * Gas leak detection breaker
- * Fire box and burglar alarm box * Other safety equipment,etc.

③ Please don't use for the uses mentioned below which require extremely high reliability.

- * Space equipment * Telecommunication equipment(Trunk)
- * Nuclear control equipment * Medical equipment(relating to any fatal element),etc.

1. Descriptions

The KP5450F00E6F is a Full Color LED consisting of small and thin form plastic leaded chip carrier (PLCC) 6-pin package, AlGaInP red chip, GaN Green, InGaN blue chip.

2. Features

- ◆ Small Footprint Surface Mount Package (5.4 L × 5.0 W × 1.6 H [mm³])
- ◆ Typical Forward Voltage(V_F) : Blue : 3.3V @ Forward Current(I_F)=20mA
Green : 3.2V @ Forward Current(I_F)=20mA
Red : 2.2V @ Forward Current(I_F)=20mA
- ◆ Operation Temperature from -40°C to +85°C
- ◆ Soldering methods : IR reflow soldering
- ◆ Taping : 12mm conductive black carrier tape & antistatic clear cover tape

3. Applications

- ◆ LCD Backlighting
- ◆ Out Door/ In Door Display
- ◆ Front panel indicator lamp
- ◆ Symbol Backlighting

4. Outline Dimensions and Material Descriptions

◆ Outline Dimensions

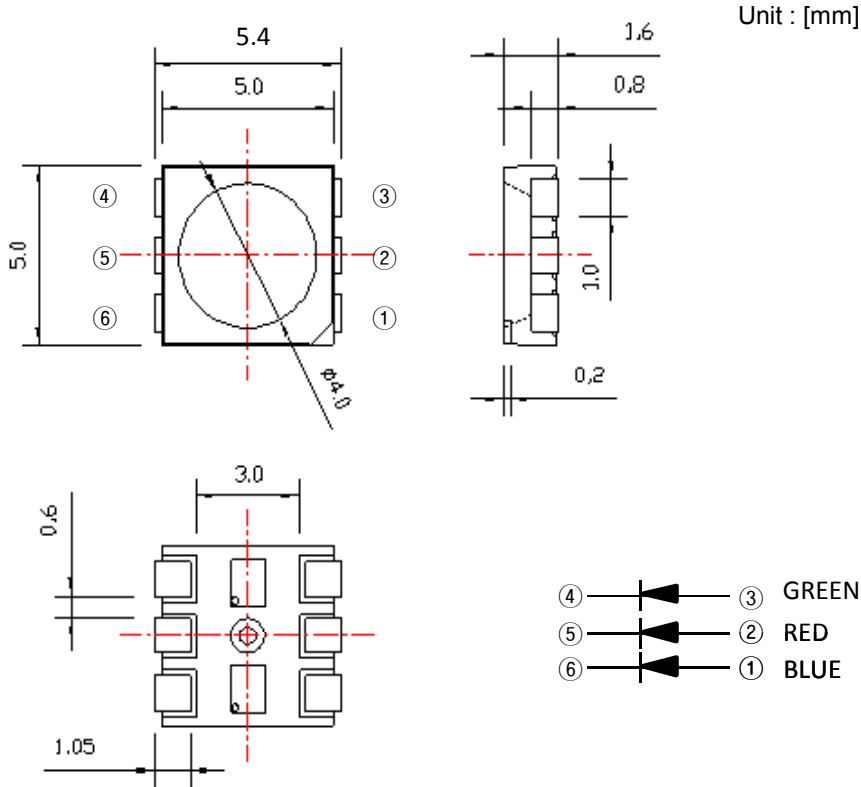

◆ Material Descriptions

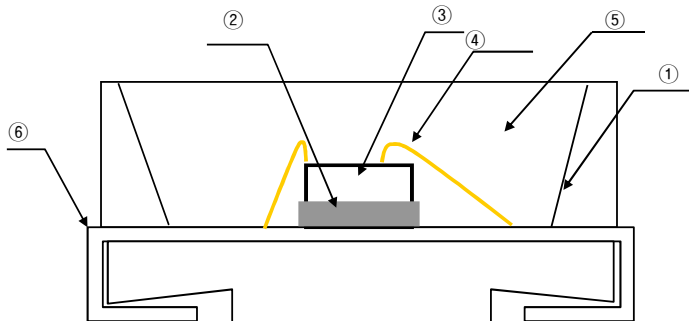

No.	Item	Material
①	Package	PPA
②	Die Adhesive	Clear Silicone
③	LED Chip	InGaN, Gap, AlGaInP
④	Wire	Au
⑤	Encapsulant	Silicone
⑥	Lead	Cu Alloy

5. Absolute Maximums

Parameter	Symbol	Ratings			Unit
		Red	Green	Blue	
Forward current	I_F	30	30	30	mA
Pulse forward current ^{*1}	I_{FP}	90	100		mA
Power dissipation	P_D	80	110	110	mW
Operating temperature	$T_{opr.}$	-30 ~ +85			°C
Storage temperature	$T_{stg.}$	-40 ~ +100			°C
Soldering Temperature ^{*2}	$T_{sol.}$	260			°C

*1. IFP was measured at $T_w \leq 1$ msec of pulse width and $D \leq 1/10$ of duty ratio.

*2. Soldering time : 5 Sec

6. Electro-Optical Characteristics ($T_A = 25^\circ\text{C}$)

Parameter		Symbol	Conditions	Min	Typ	Max	Unit
Forward voltage	Red	V_F	$I_F=20\text{mA}$	1.8	-	2.5	V
	Green			2.8	-	3.6	
	Blue			2.8	-	3.6	
Dominant Wavelength	Red	W_D	$I_F=20\text{mA}$	615	-	630	nm
	Green			510	-	530	
	Blue			455	-	475	
Luminous Intensity	Red	I_v	$I_F=20\text{mA}$	200	-	600	mcd
	Green			600	-	1800	
	Blue			120	-	400	
Luminous intensity ^{*1,3}	R,G,B	I_v	700	1000	1500	mcd	Red_ I_F =12mA, Green_ I_F =10mA, Blue_ I_F =7mA
Chromaticity coordiante ^{*3}	R,G,B	x	0.250	-	0.350	-	Red_ I_F =12mA, Green_ I_F =10mA, Blue_ I_F =7mA
		y	0.250	-	0.350	-	
Reverse Current		I_R	$V_R=5\text{V}$	-	-	10	uA
Half angle ^{*2}		$2\Delta\theta_{1/2}$	$I_F=60\text{mA}$	-	120	-	deg.

*1. The luminous intensity I_v was measured at the peak of the spatial pattern which may not be aligned with the mechanical axis of the LED package.

*2. $2\theta_{1/2}$ is the off-axis where the luminous intensity is 1/2 of the peak intensity.

7. Ranks

◆ I_v , Color Rank Table^{*1}

I_v , Color Rank @ Red $_I_F$ = 12 mA, Green $_I_F$ = 10 mA, Blue $_I_F$ = 7 mA			
Luminous Intensity [mcd]	Chromaticity		-
T : 700 ~ 1000	A1	E1	-
U : 1000 ~ 1200	B1	F1	-
V : 1200 ~ 1500	C1	G1	-
-	D1	H1	-

*1. KP5450F00E6F marked as TA1(I_v , Color Rank) has the I_v range 0.7~1.0cd and Color range A1 area.

◆ Color Coordinate Rank

A1		B1		C1		D1	
x	y	x	y	x	y	x	y
0.2600	0.3500	0.2575	0.3250	0.2550	0.3000	0.2525	0.2750
0.2575	0.3250	0.2550	0.3000	0.2525	0.2750	0.2500	0.2500
0.3025	0.3250	0.3000	0.3000	0.2975	0.2750	0.2950	0.2500
0.3050	0.3500	0.3025	0.3250	0.3000	0.3000	0.2975	0.2750
E1		F1		G1		H1	
x	y	x	y	x	y	x	y
0.2525	0.2250	0.3025	0.3250	0.3000	0.3000	0.2975	0.2750
0.2650	0.2250	0.3000	0.3000	0.2975	0.2750	0.2950	0.2500
0.2800	0.2550	0.3450	0.3000	0.3425	0.2750	0.3400	0.2500
0.2675	0.2550	0.3475	0.3250	0.3450	0.3000	0.3425	0.2750

◆ The CIE(x, y) Chromaticity Diagram

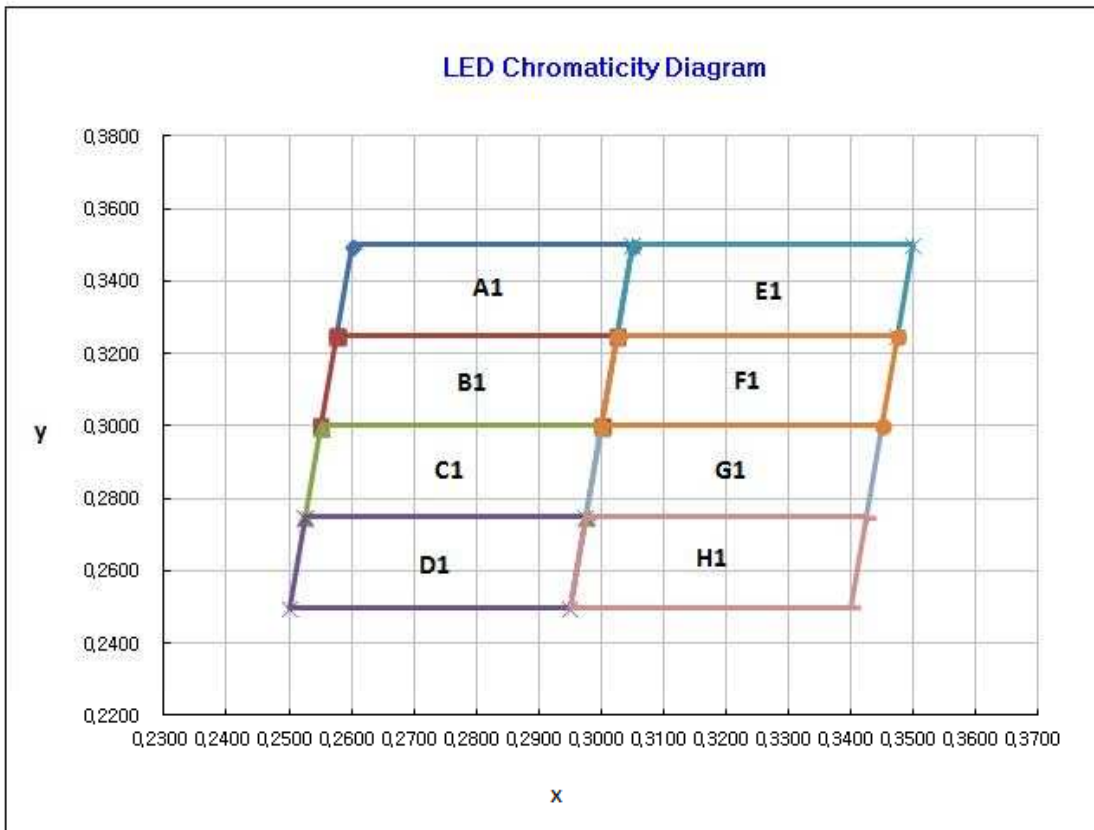

8. Part Numbering

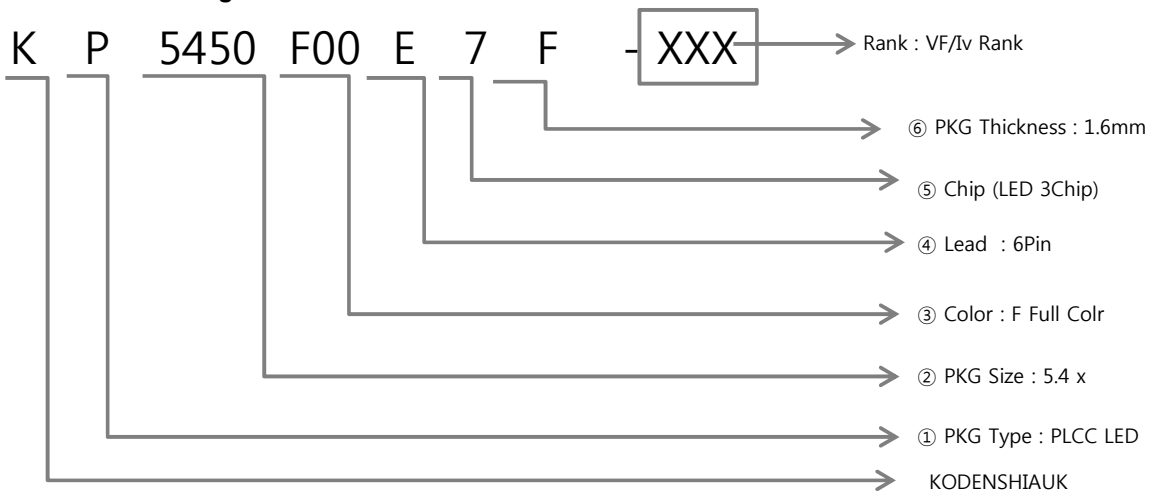

9. Characteristic Graphs

Forward current vs. Ambient temperature

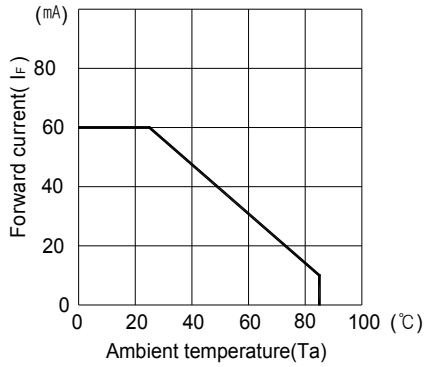

luminous Intensity vs. Forward current

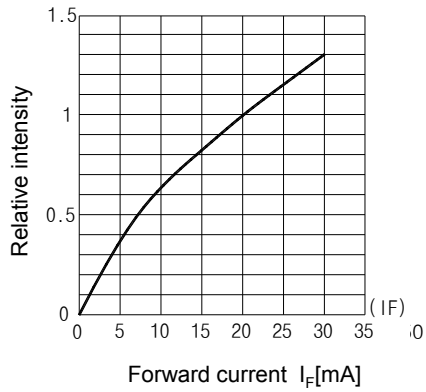

Relative luminous intensity vs. Ambient temperature

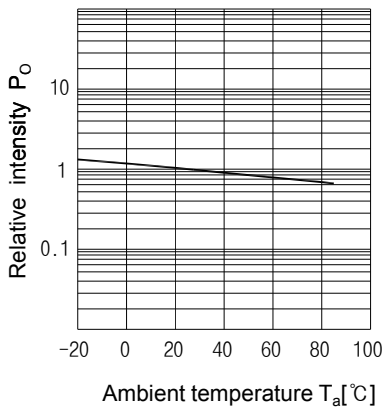

Relative intensity vs. Wavelength

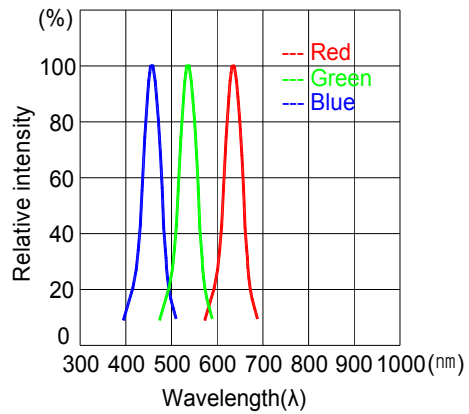

Forward current vs. Forward voltage

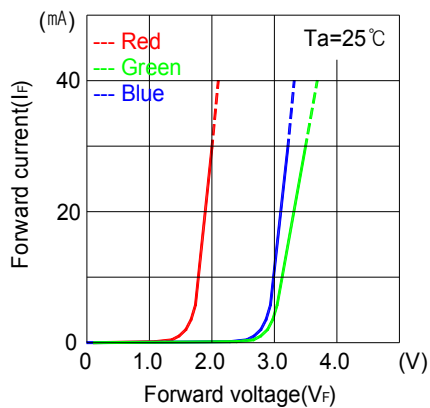

Radiant Pattern

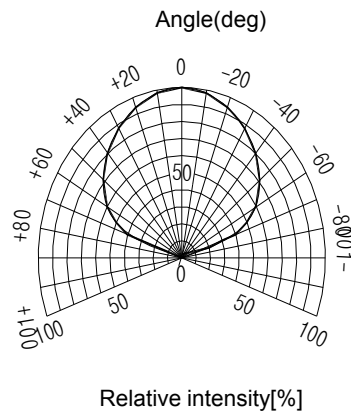

10. Reliability Test

◆ Criteria

ITEM	Symbol	Test Conditions	Criteria for Judgement	
			Min.	Max.
Forward Voltage	V_F	$I_F = 60\text{mA}$	-	U.S.L. $\times 1.2$
Reverse Current	I_R	$V_R = 5\text{V}$	-	U.S.L. $\times 2.0$
Luminous Intensity	I_V	$I_F = 60\text{mA}$	L.S.L. $\times 0.5$	-

U.S.L. : Upper Standard Level

L.S.L. : Lower Standard Level

◆ Test Conditions

No.	Test ITEM	Standard Test Method	Test Conditions	Note	#of Damaged/ Test No.
1	Resistance to Solder Heat (Reflow Soldering)	$T_{\text{slid}} = 260^\circ\text{C}$, 10sec.	6 Min	22 PCS	0/1
2	Temperature Cycle	H : $+100^\circ\text{C}$ 15min ↓ 5 min L : -40°C 15min	300 Cycles	22 PCS	0/1
3	Thermal Shock	H : $+100^\circ\text{C}$ 5min ↓ 10 sec L : -10°C 5min	300 Cycles	22 PCS	0/1
4	High Temperature Storage	$T_a = 100^\circ\text{C}$	1000 hrs.	22 PCS	0/1
5	Low Temperature Storage	$T_a = -40^\circ\text{C}$	1000 hrs.	22 PCS	0/1
6	DC Operating Life	25°C , $I_F = 60\text{mA}$	1000 hrs.	22 PCS	0/1
7	High Temperature / High Humidity	$85^\circ\text{C} / 85\%\text{RH}$	1000 hrs.	22 PCS	0/1

11. Recommended Soldering Pattern

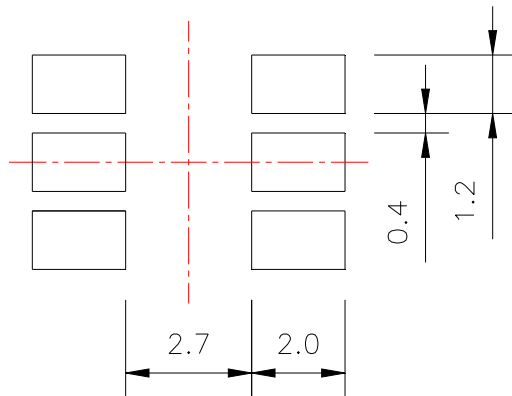

Unit : [mm]

12. Reflow Soldering Profile

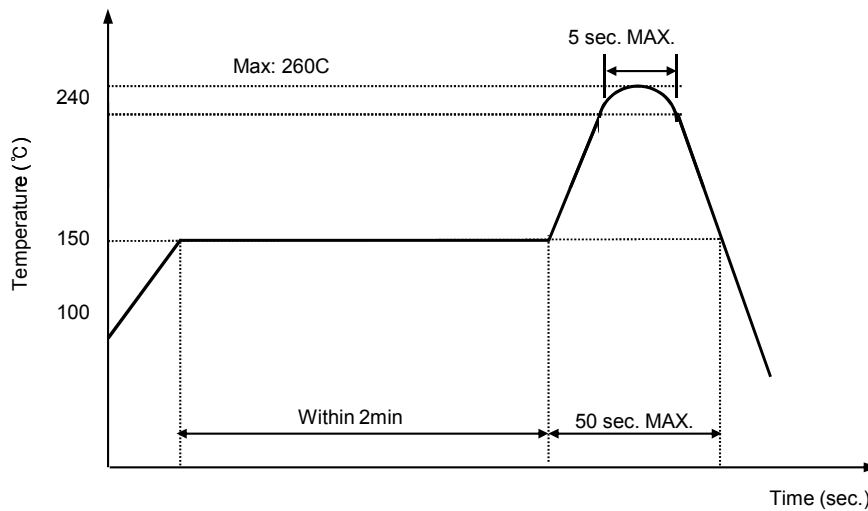

13. Manual Soldering Codition

For manual soldring, you have to complete soldering within 3 seconds under 260°C.
 (The temperature at tip of solder iron).

14. Tape and Reel Specifications

◆ Tape

UNIT : [mm]

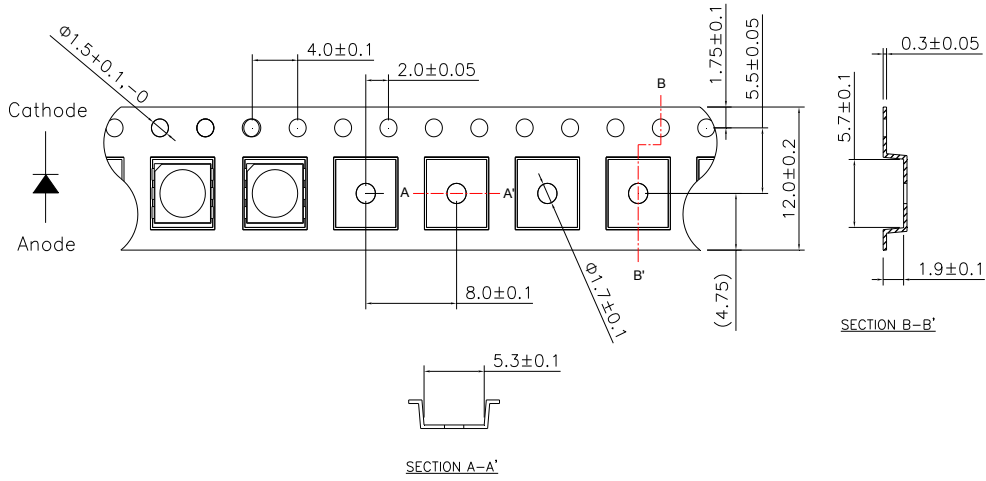

◆ Reel

UNIT : [mm]

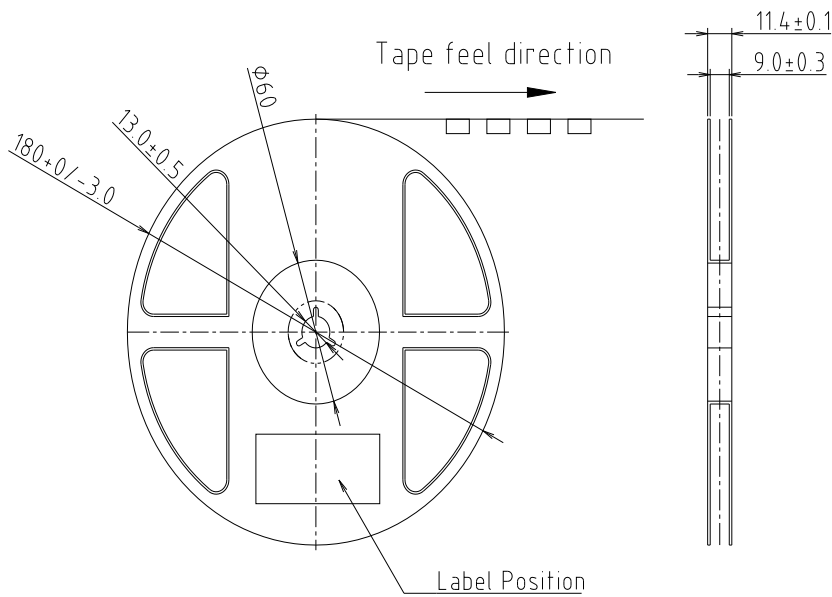

- ◆ Quantity : 1,000pcs/Reel
- ◆ Cover Tape Adhesion : 0.1 ~ 0.7N for 45° pulling up.

15. Packing Specifications

UNIT : [mm]

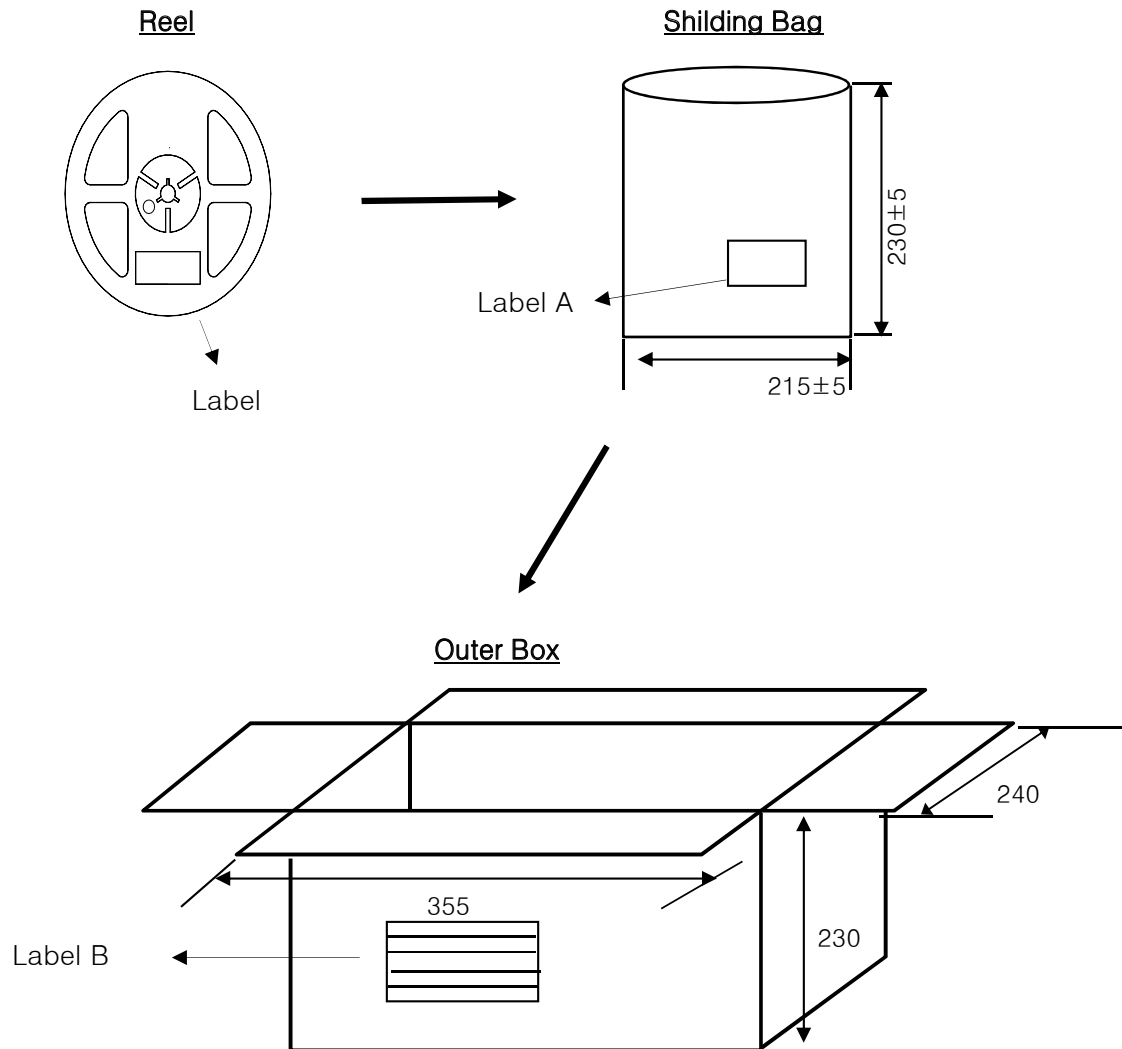

◆ Specifications of Carrier Tape, Reel and Shilding Bag

Item	Carrier Tape	Reel	Shilding Bag	
			Outside	Inside
Surface Conductivity	$1 \times 10^4 \sim 1 \times 10^6$	1×10^8	$1 \times 10^{10} \sim 1 \times 10^{12}$	$1 \times 10^{11} \sim 1 \times 10^{13}$

16. Label

◆ Label A



◆ Label B



17. Cautions

◆ Cautions in Usage

- Store and use where there is no exterior force that will cause change in shape.
- Store and use where there is no Hydrogen Sulfide gas, or any other corrosive gas.
- Once the package is opened, the products should be used within 3 days. Otherwise, they should be kept in a damp proof box with desiccating agent. Considering the tape life, we suggest our customers to use our products within a year(from production date)
- If opened more than 3 days in an atmosphere 5 °C ~35 °C, RH 60%, they should be treated at 60 °C ±5 °C for 15 hrs.
- Solder the lead pin under conditions of the absolute maximum rating chart and do not apply force on the solder pin after soldering.

◆ Guarantee Period and Scope

- Period
One year after delivery to the desired place.
- Scope
Replacement of products will be done if any problems lie in our company's products. However, we are not liable for your damage due to lack of caution.

◆ Others

- Any doubts concerning this specification should be discussed fully by both parties.