



Precision, Single-Supply, SPST Analog Switches

MAX323/MAX324/MAX325

General Description

Features

The MAX323/MAX324/MAX325 are precision, dual, SPST analog switches. They are single-supply devices designed to operate from +2.7V to +16V. The MAX323 has two normally open (NO) switches, and the MAX324 has two normally closed (NC) switches. The MAX325 has one NO and one NC switch. Low power consumption (5μW) makes these parts ideal for battery-powered equipment. These switches offer low leakage currents (100pA max) and fast switching speeds (t_{ON} = 150ns max, t_{OFF} = 100ns max).

- ◆ Low On-Resistance (R_{ON}), 60Ω max (33Ω typ)
- ◆ R_{ON} Matching Between Channels <2Ω
- ◆ R_{ON} Flatness <6Ω Max
- ◆ Guaranteed Charge Injection <5pC
- ◆ Single-Supply Operation (+2.7V to +16V)
- ◆ Low Power Consumption, <5μW
- ◆ Low Leakage Current Over Temperature, <2.5nA at +85°C
- ◆ Fast Switching: t_{ON} <150ns, t_{OFF} <100ns
- ◆ Guaranteed Break-Before-Make (MAX325 only)
- ◆ TTL/CMOS Logic Compatible

When powered from a 5V supply, the MAX323 series offers 2Ω max matching between channels, 60Ω max on-resistance, and 6Ω max R_{ON} flatness.

These switches also offer 5pC max charge injection, and a minimum of 2000V ESD per Method 3015.7.

For equivalent devices specified for dual-supply operation, see the MAX320/MAX321/MAX322 data sheet. For quad versions of the MAX320 series, see MAX391/MAX392/MAX393 data sheet.

Ordering Information

PART	TEMP. RANGE	PIN-PACKAGE
MAX323CPA	0°C to +70°C	8 Plastic DIP
MAX323CUA	0°C to +70°C	8 μMAX
MAX323CSA	0°C to +70°C	8 SO
MAX323C/D	0°C to +70°C	Dice*
MAX323EPA	-40°C to +85°C	8 Plastic DIP
MAX323ESA	-40°C to +85°C	8 SO
MAX323EJA	-40°C to +85°C	8 CERDIP**
MAX323MJA	-55°C to +125°C	8 CERDIP**

Ordering Information continued at end of data sheet.

* Contact factory for dice specifications.

** Contact factory for availability.

Applications

- | | |
|---------------------------|------------------------------|
| Battery-Operated Systems | Sample-and-Hold Circuits |
| Heads-Up Displays | Guidance and Control Systems |
| Audio and Video Switching | Military Radios |
| Test Equipment | Communications Systems |
| +3V, +5V DACs and ADCs | PBX, PABX |

Pin Configurations/Functional Diagrams/Truth Tables

TOP VIEW

MAX323
DIP/SO/μMAX

MAX323	
LOGIC	SWITCH
0	OFF
1	ON

MAX324
DIP/SO/μMAX

MAX324	
LOGIC	SWITCH
0	ON
1	OFF

MAX325
DIP/SO/μMAX

MAX325		
LOGIC	SWITCH 1	SWITCH 2
0	OFF	ON
1	ON	OFF

SWITCHES SHOWN FOR LOGIC "0" INPUT



Precision, Single-Supply, SPST Analog Switches

ABSOLUTE MAXIMUM RATINGS

Voltage Referenced to GND		CERDIP (derate 8.00mW/°C above +70° C)640mW
V+	-0.3V to +17V	μMAX (derate 4.10mW/°C above +70° C)330mW
IN_, COM_, NC_, NO_ (Note 1)	-0.3V to (V+ + 0.3V)	Operating Temperature Ranges
Continuous Current (any terminal)	30mA	MAX32_C_0°C to +70°C
Peak Current, COM_, NO_, NC_ (pulsed at 1ms, 10% duty cycle max)	100mA	MAX32_E_-40°C to +85°C
ESD per Method 3015.7	>2000V	MAX32_MJA-55°C to +125°C
Continuous Power Dissipation		Storage Temperature Range-65°C to +150°C
Plastic DIP (derate 9.09mW/°C above +70° C)	727mW	Lead Temperature (soldering, 10sec)+300°C
Narrow SO (derate 5.88mW/°C above +70° C)	471mW	

Note 1: Signals on NC, NO, COM, or IN exceeding V+ or V- are clamped by internal diodes. Limit forward diode current to maximum current rating.

Stresses beyond those listed under "Absolute Maximum Ratings" may cause permanent damage to the device. These are stress ratings only, and functional operation of the device at these or any other conditions beyond those indicated in the operational sections of the specifications is not implied. Exposure to absolute maximum rating conditions for extended periods may affect device reliability.

ELECTRICAL CHARACTERISTICS—Single +5V Supply

(V+ = 5V ±10%, GND = 0V, VINH = 2.4V, VINL = 0.8V, TA = TMIN to TMAX, unless otherwise noted.)

PARAMETER	SYMBOL	CONDITIONS		MIN	TYP (Note 2)	MAX	UNITS	
ANALOG SWITCH								
Analog Signal Range	VCOM, VNO, VNC	(Note 3)		0		V+	V	
On-Resistance	RON	V+ = 4.5V, ICOM = 1.0mA, VNO or VNC = 3.5V	TA = +25°C		33	60	Ω	
			TA = TMIN to TMAX			75		
On-Resistance Match Between Channels (Note 4)	ΔRON	V+ = 5V, ICOM = 1.0mA, VNO or VNC = 3V	TA = +25°C		0.8	2	Ω	
			TA = TMIN to TMAX			4		
On-Resistance Flatness (Notes 3, 5)	RFLAT(ON)	V+ = 5V, ICOM = 1.0mA, VNO or VNC = 1V, 2V, 3V	TA = +25°C		2	6	Ω	
			TA = TMIN to TMAX			8		
NO or NC Off Leakage Current (Note 6)	INO(OFF) or INC(OFF)	V+ = 5.5V, VCOM = 1V, VNO or VNC = 4.5V	TA = +25°C		-0.1	0.01	nA	
			TA = TMIN to TMAX	C, E		-5		5
				M		-40		40
COM Off Leakage Current (Note 6)	ICOM(OFF)	V+ = 5.5V, VCOM = 4.5V, VNO or VNC = 1V	TA = +25°C		-0.1	0.1	nA	
			TA = TMIN to TMAX	C, E		-5		5
				M		-40		40
COM On Leakage Current (Note 6)	ICOM(ON)	V+ = 5.5V, VCOM = 5V, or VNO or VNC = 5V	TA = +25°C		-0.2	0.2	nA	
			TA = TMIN to TMAX	C, E		-10		10
				M		-50		50

Precision, Single-Supply, SPST Analog Switches

MAX323/MAX324/MAX325

ELECTRICAL CHARACTERISTICS—Single +5V Supply (continued)

($V_+ = 5V \pm 10\%$, $GND = 0V$, $V_{INH} = 2.4V$, $V_{INL} = 0.8V$, $T_A = T_{MIN}$ to T_{MAX} , unless otherwise noted.)

PARAMETER	SYMBOL	CONDITIONS	MIN	TYP (Note 2)	MAX	UNITS
DYNAMIC						
Turn-On Time	t_{ON}	V_{NO} or $V_{NC} = 3V$	$T_A = +25^\circ C$	85	150	ns
			$T_A = T_{MIN}$ to T_{MAX}		240	
Turn-Off Time	t_{OFF}	V_{NO} or $V_{NC} = 3V$	$T_A = +25^\circ C$	25	100	ns
			$T_A = T_{MIN}$ to T_{MAX}		150	
Break-Before-Make Time Delay (Note 3)	t_D	MAX325 only, $R_L = 300\Omega$, $C_L = 35pF$	2			ns
Charge Injection (Note 3)	Q	$C_L = 1.0nF$, $V_{GEN} = 0V$, $R_{GEN} = 0V$, Figure 4		1	5	pC
Off Isolation (Note 7)	OIRR	$R_L = 50\Omega$, $C_L = 5pF$, $f = 1MHz$, Figure 5		72		dB
Crosstalk (Note 8)		$R_L = 50\Omega$, $C_L = 5pF$, $f = 1MHz$, Figure 6		85		dB
NC or NO Capacitance	C_{OFF}	$f = 1MHz$, Figure 7		9		pF
COM Off Capacitance	$C_{COM(OFF)}$	$f = 1MHz$, Figure 7		9		pF
COM On Capacitance	$C_{COM(ON)}$	$f = 1MHz$, Figure 8		22		pF
SUPPLY						
Power-Supply Range			2.7		16	V
Positive Supply Current	I+	$V_+ = 5.5V$, $V_{IN} = 0V$ or V_+ , all channels on or off	-1	0.0001	1	μA
LOGIC INPUT						
Input Voltage Low	V_{INL}				0.8	V
Input Voltage High	V_{INH}		2.4			V

Precision, Single-Supply, SPST Analog Switches

ELECTRICAL CHARACTERISTICS—Single +3.3V Supply

(V+ = 3.0V to 3.6V, GND = 0V, VINH = 2.4V, VINL = 0.6V, TA = TMIN to TMAX, unless otherwise noted.)

PARAMETER	SYMBOL	CONDITIONS		MIN	TYP (Note 2)	MAX	UNITS
ANALOG SWITCH							
Analog Signal Range	VCOM, VNO, VNC	(Note 3)		0		V+	V
Channel On-Resistance	RON	V+ = 3V, ICOM = 1.0mA, VNO or VNC = 1.5V	TA = +25°C	83	175		Ω
			TA = TMIN to TMAX			275	
DYNAMIC							
Turn-On Time (Note 3)	tON	VNO or VNC = 1.5V	TA = +25°C	160	400		ns
			TA = TMIN to TMAX			500	
Turn-Off Time (Note 3)	tOFF	VNO or VNC = 1.5V	TA = +25°C	40	125		ns
			TA = TMIN to TMAX			175	
Break-Before-Make Time Delay (Note 3)	tD	MAX325 only, RL = 300Ω, CL = 35pF	TA = +25°C	2	5		ns
Charge Injection (Note 3)	Q	CL = 1.0nF, VGEN = 0V, RGEN = 0V	TA = +25°C		1	5	pC
SUPPLY							
Positive Supply Current	I+	V+ = 3.6V, VIN = 0V or V+, all channels on or off		-1		1	μA

Note 2: The algebraic convention, where the most negative value is a minimum and the most positive value a maximum, is used in this data sheet.

Note 3: Guaranteed by design.

Note 4: $\Delta R_{ON} = \Delta R_{ON\ max} - \Delta R_{ON\ min}$.

Note 5: Flatness is defined as the difference between the maximum and minimum value of on-resistance as measured over the specified analog signal range.

Note 6: Leakage parameters are 100% tested at maximum rated hot temperature and guaranteed by correlation at +25°C.

Note 7: Off Isolation = $20 \log_{10} [V_{COM} / (V_{NC} \text{ or } V_{NO})]$, VCOM = output, VNC or VNO = input to off switch.

Note 8: Between any two switches.

Precision, Single-Supply, SPST Analog Switches

Typical Operating Characteristics

($T_A = +25^\circ\text{C}$, unless otherwise noted.)

MAX323/MAX324/MAX325

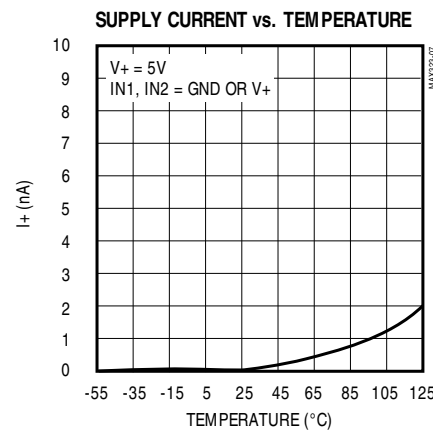
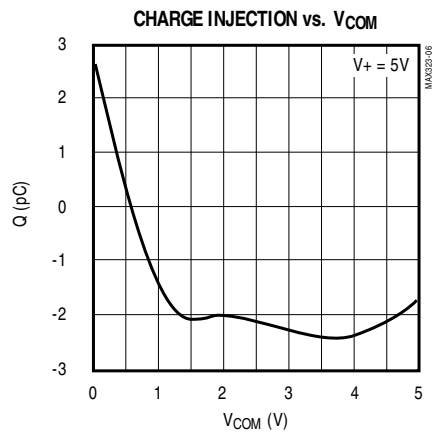
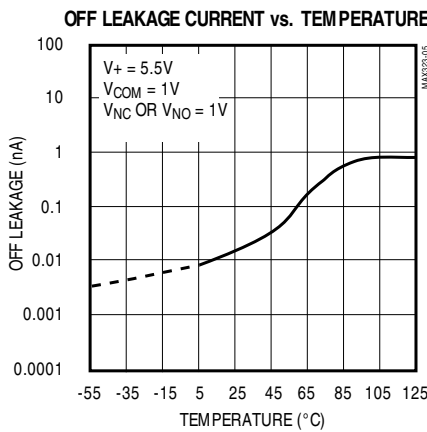
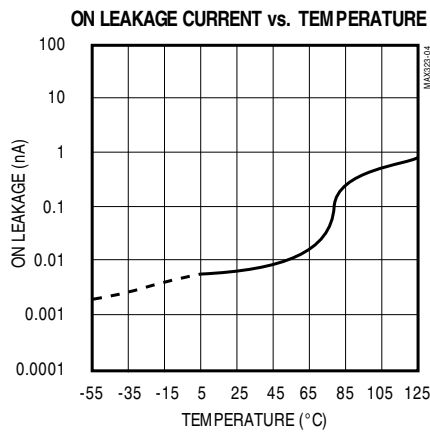
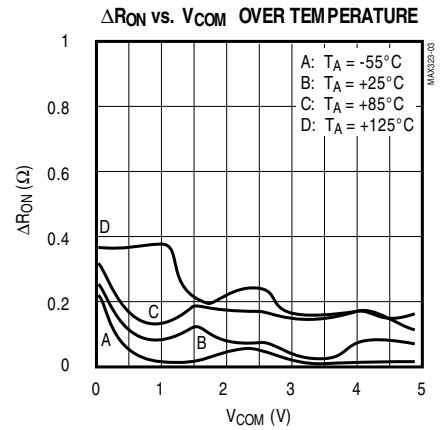
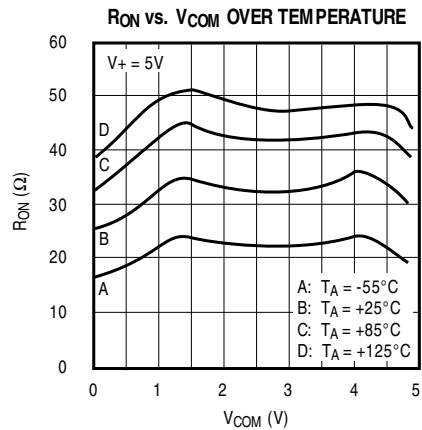
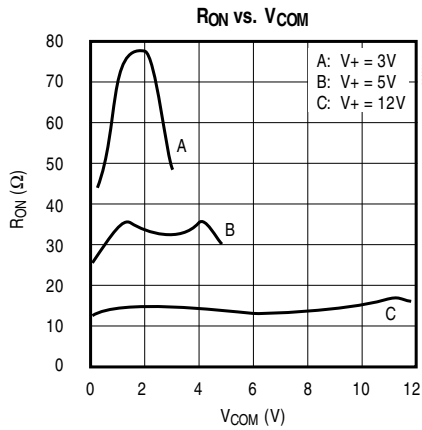

Precision, Single-Supply, SPST Analog Switches

Pin Description

PIN	NAME	FUNCTION
1	NO1	Normally Open Analog Switch Terminal (MAX323/MAX325)
	NC1	Normally Closed Analog Switch Terminal (MAX324 only)
2, 6	COM1, COM2	Analog Switch Common Terminal
3, 7	IN2, IN1	Logic Inputs
4	GND	Ground
5	NO2	Normally Open Analog Switch Terminal (MAX323 only)
	NC2	Normally Closed Analog Switch Terminal (MAX324/MAX325)
8	V+	Positive Supply

Applications Information

Logic Levels

The MAX323/MAX324/MAX325 are TTL compatible when powered from a single +5V supply. When powered from other supply voltages, TTL compatibility is not guaranteed, and the logic inputs should be driven from rail to rail. For example, with a 15V supply, IN1 and IN2 should be driven low to 0V and high to 15V. Similarly, with a 3.3V supply, IN1 and IN2 should be driven low to 0V and high to 3.3V.

Driving IN1 and IN2 rail-to-rail minimizes power consumption.

Analog Signal Levels

Analog signals that range over the entire supply voltage (V+ to GND) can be switched with very little change in on-resistance over the entire voltage range (see *Typical Operating Characteristics*). All the switches are bidirectional, so NO_, NC_, and COM_ pins can be used as either inputs or outputs.

Power-Supply Sequencing and Overvoltage Protection

Do not exceed the absolute maximum ratings, because stresses beyond the listed ratings may cause permanent damage to the devices.

Proper power-supply sequencing is recommended for all CMOS devices. Always apply V+ before applying analog signals or logic inputs, especially if the analog

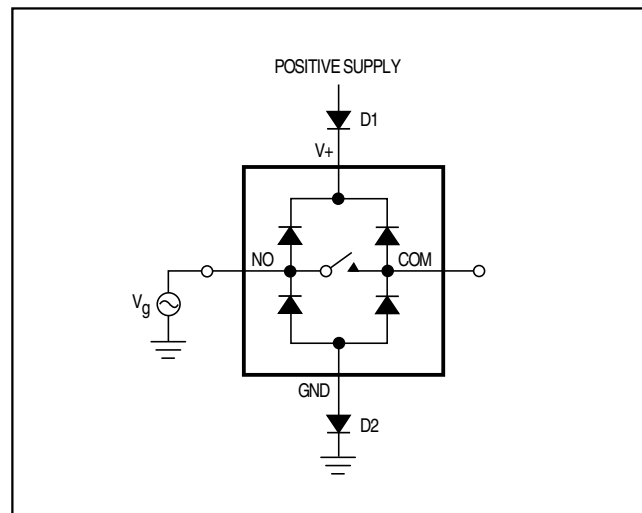

Figure 1. Overvoltage Protection Using Two External Blocking Diodes

or logic signals are not current-limited. If this sequencing is not possible, and if the analog or logic inputs are not current-limited to <30mA, add a small-signal diode (D1) as shown in Figure 1. If the analog signal can dip below GND, add D2. Adding protection diodes reduces the analog signal range to a diode-drop (about 0.7V) below V+ (for D1), and to a diode-drop above ground (for D2). Leakage is unaffected by adding the diodes. On-resistance increases by a small amount at low supply voltages. Maximum supply voltage (V+) must not exceed 17V.

Adding protection diodes causes the logic thresholds to be shifted relative to the power-supply rails. This can be significant when low supply voltages (5V or less) are used. With a 5V supply, TTL compatibility is not guaranteed when protection diodes are added. Driving IN1 and IN2 all the way to the supply rails (i.e. to a diode-drop higher than the V+ pin, or to a diode-drop lower than the GND pin) is always acceptable.

Protection diodes D1 and D2 also protect against some overvoltage situations. With Figure 1's circuit, if the supply voltage is below the absolute maximum rating, and if a fault voltage up to the absolute maximum rating is applied to an analog signal pin, no damage will result. For example, with a +5V supply, analog signals up to $\pm 8V$ will not damage the circuit of Figure 1. If only a single fault signal is present, the fault voltage can rise to +17V or to -12V without damage occurring.

Precision, Single-Supply, SPST Analog Switches

Test Circuits/Timing Diagrams

MAX323/MAX324/MAX325

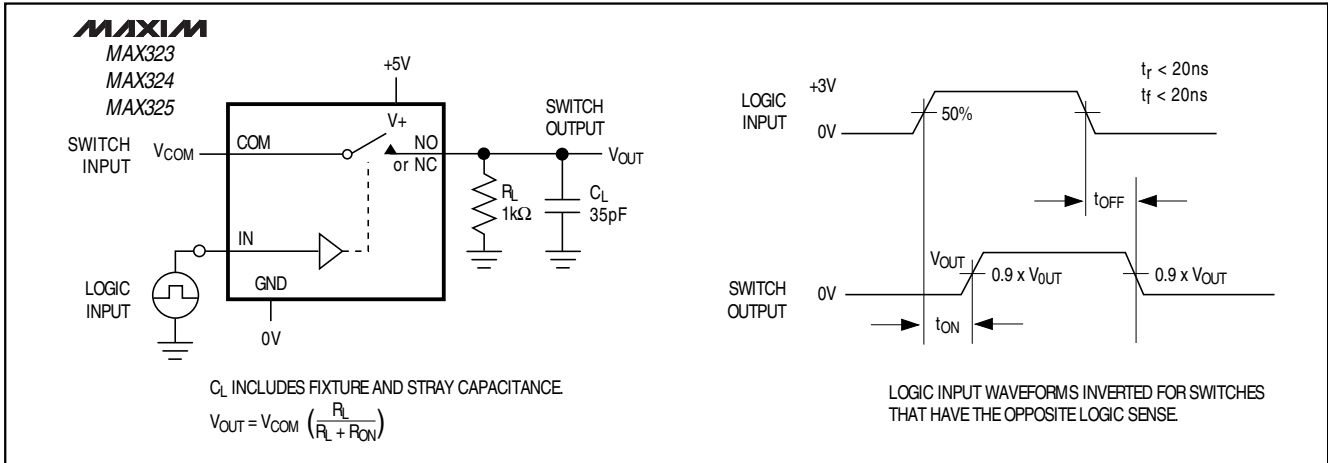

Figure 2. Switching Time

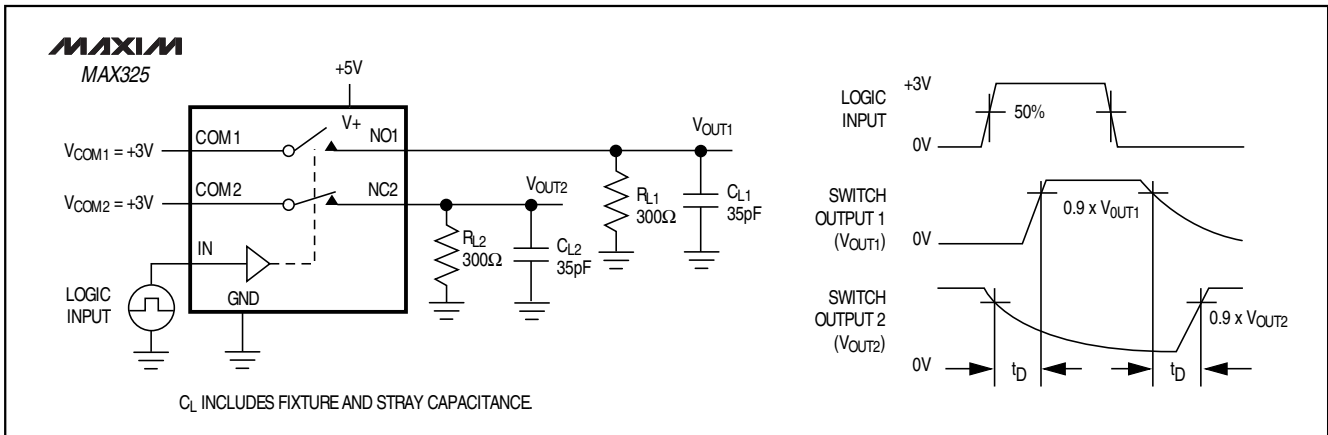

Figure 3. Break-Before-Make Interval (MAX325 only)

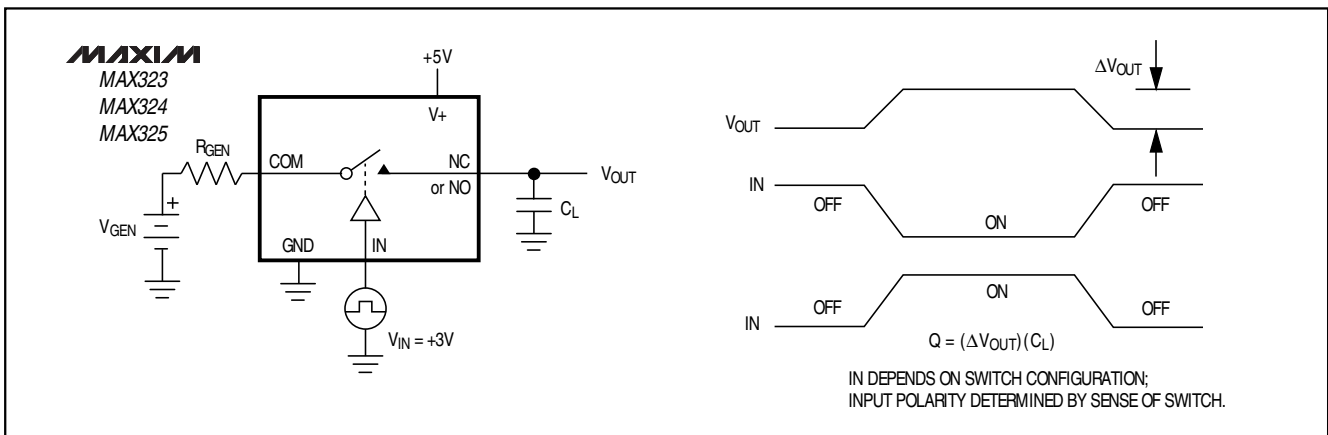

Figure 4. Charge Injection

Precision, Single-Supply, SPST Analog Switches

Test Circuits/Timing Diagrams (continued)

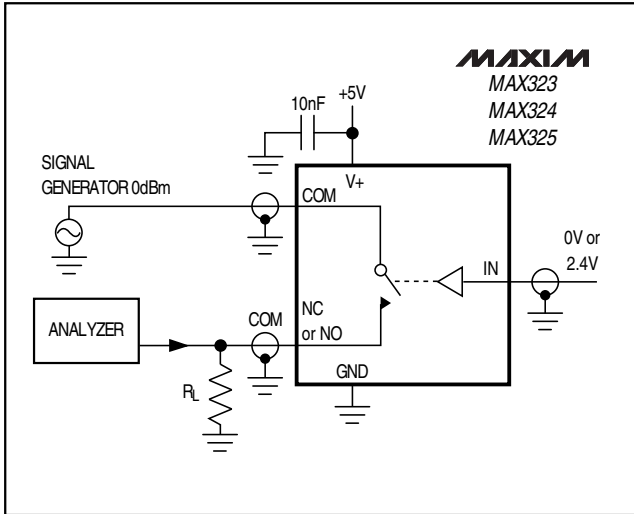

Figure 5. Off Isolation

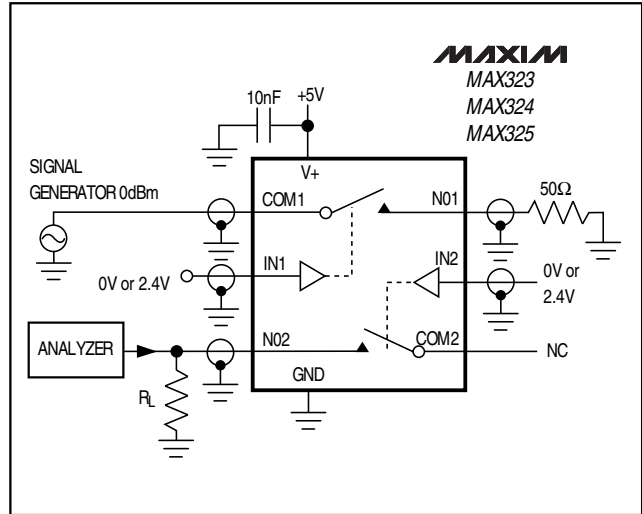

Figure 6. Crosstalk

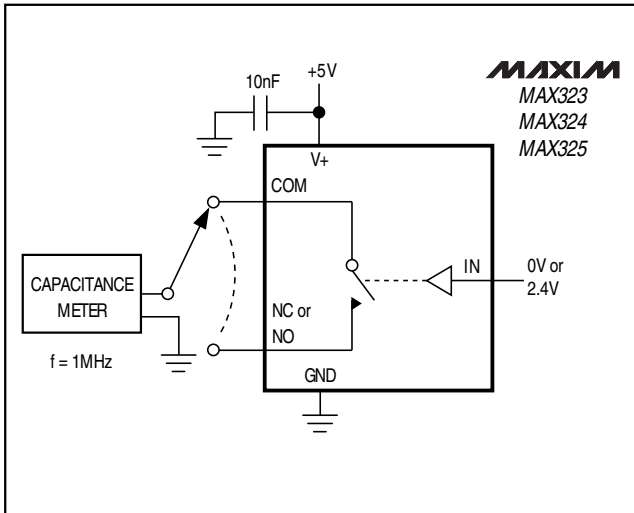

Figure 7. Channel-Off Capacitance

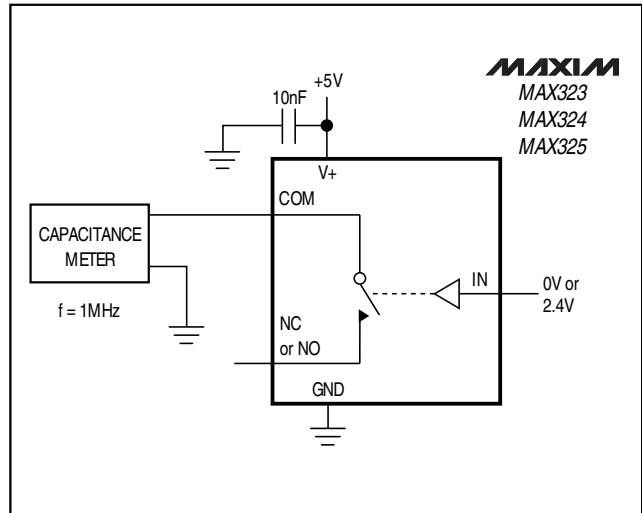

Figure 8. Channel-On Capacitance

Precision, Single-Supply, SPST Analog Switches

Ordering Information (continued)

PART	TEMP. RANGE	PIN-PACKAGE
MAX324CPA	0°C to +70°C	8 Plastic DIP
MAX324CUA	0°C to +70°C	8 μ MAX
MAX324CSA	0°C to +70°C	8 SO
MAX324C/D	0°C to +70°C	Dice*
MAX324EPA	-40°C to +85°C	8 Plastic DIP
MAX324ESA	-40°C to +85°C	8 SO
MAX324EJA	-40°C to +85°C	8 CERDIP**
MAX324MJA	-55°C to +125°C	8 CERDIP**
MAX325CPA	0°C to +70°C	8 Plastic DIP
MAX325CUA	0°C to +70°C	8 μ MAX
MAX325CSA	0°C to +70°C	8 SO
MAX325C/D	0°C to +70°C	Dice*
MAX325EPA	-40°C to +85°C	8 Plastic DIP
MAX325ESA	-40°C to +85°C	8 SO
MAX325EJA	-40°C to +85°C	8 CERDIP**
MAX325MJA	-55°C to +125°C	8 CERDIP**

* Contact factory for dice specifications.

** Contact factory for availability.

Chip Topography

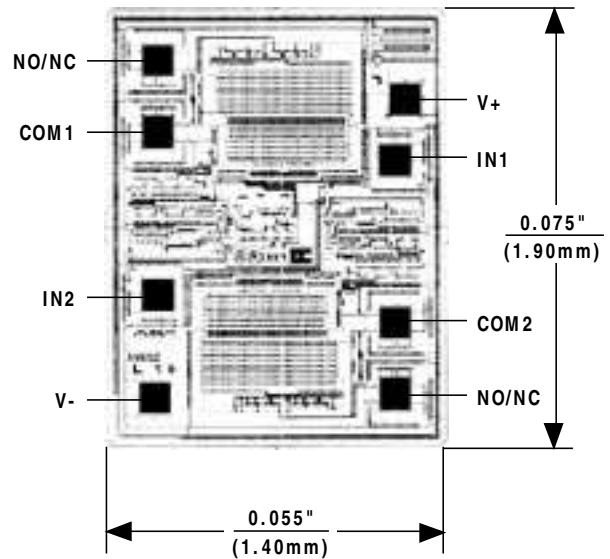

MAX323/MAX324/MAX325

TRANSISTOR COUNT: 91
SUBSTRATE IS CONNECTED TO V+

Precision, Single-Supply, SPST Analog Switches

Package Information

DIM	INCHES		MILLIMETERS	
	MIN	MAX	MIN	MAX
A	0.036	0.044	0.91	1.11
A1	0.004	0.008	0.10	0.20
B	0.010	0.014	0.25	0.36
C	0.005	0.007	0.13	0.18
D	0.116	0.120	2.95	3.05
E	0.116	0.120	2.95	3.05
e	0.0256		0.65	
H	0.188	0.198	4.78	5.03
L	0.016	0.026	0.41	0.66
α	0°	6°	0°	6°

**8-PIN μMAX
MICROMAX SMALL OUTLINE
PACKAGE**

DIM	INCHES		MILLIMETERS	
	MIN	MAX	MIN	MAX
A	–	0.200	–	5.08
A1	0.015	–	0.38	–
A2	0.125	0.175	3.18	4.45
A3	0.055	0.080	1.40	2.03
B	0.016	0.022	0.41	0.56
B1	0.045	0.065	1.14	1.65
C	0.008	0.012	0.20	0.30
D1	0.005	0.080	0.13	2.03
E	0.300	0.325	7.62	8.26
E1	0.240	0.310	6.10	7.87
e	0.100	–	2.54	–
eA	0.300	–	7.62	–
eB	–	0.400	–	10.16
L	0.115	0.150	2.92	3.81

DIM	PINS	INCHES		MILLIMETERS	
		MIN	MAX	MIN	MAX
D	8	0.348	0.390	8.84	9.91
D	14	0.735	0.765	18.67	19.43
D	16	0.745	0.765	18.92	19.43
D	18	0.885	0.915	22.48	23.24
D	20	1.015	1.045	25.78	26.54
D	24	1.14	1.265	28.96	32.13

**Plastic DIP
PLASTIC
DUAL-IN-LINE
PACKAGE
(0.300 in.)**

Precision, Single-Supply, SPST Analog Switches

Package Information (continued)

MAX323/MAX324/MAX325

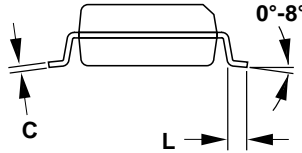
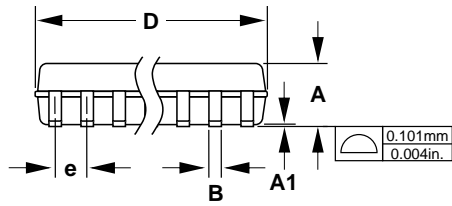

DIM	INCHES		MILLIMETERS	
	MIN	MAX	MIN	MAX
A	0.053	0.069	1.35	1.75
A1	0.004	0.010	0.10	0.25
B	0.014	0.019	0.35	0.49
C	0.007	0.010	0.19	0.25
E	0.150	0.157	3.80	4.00
e	0.050		1.27	
H	0.228	0.244	5.80	6.20
L	0.016	0.050	0.40	1.27

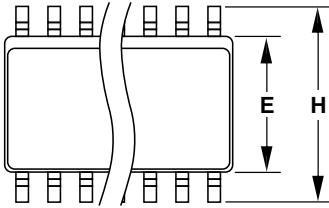

**SO
SMALL OUTLINE
PACKAGE
(0.150 in.)**

DIM	PINS	INCHES		MILLIMETERS	
		MIN	MAX	MIN	MAX
D	8	0.189	0.197	4.80	5.00
D	14	0.337	0.344	8.55	8.75
D	16	0.386	0.394	9.80	10.00

21-0041A

Precision, Single-Supply, SPST Analog Switches

Package Information (continued)

**Ceramic SB
CERAMIC SIDEBRAZE
PACKAGE
(0.300 in.)**

DIM	INCHES		MILLIMETERS	
	MIN	MAX	MIN	MAX
A	–	0.225	–	5.72
B	0.014	0.023	0.36	0.58
B2	0.038	0.065	0.97	1.65
C	0.008	0.015	0.20	0.38
E	0.220	0.310	5.59	7.87
eA	0.290	0.320	7.37	8.13
e	0.100		2.54	
L	0.125	0.200	3.18	5.08
Q	0.015	0.070	0.38	1.78
S1	0.005	–	0.13	–

DIM	PINS	INCHES		MILLIMETERS	
		MIN	MAX	MIN	MAX
D	8	–	0.550	–	13.97
D	14	–	0.785	–	19.94
D	16	–	0.840	–	21.34
D	18	–	0.960	–	24.38
D	20	–	1.060	–	26.92
D	24	–	1.280	–	32.51

Maxim cannot assume responsibility for use of any circuitry other than circuitry entirely embodied in a Maxim product. No circuit patent licenses are implied. Maxim reserves the right to change the circuitry and specifications without notice at any time.

12 Maxim Integrated Products, 120 San Gabriel Drive, Sunnyvale, CA 94086 408-737-7600