



# VOLTAGE CONTROLLED CRYSTAL OSCILLATORS HCMOS/TTL 5V

FULL SIZE D.I.L.  
M package  
M6306



## Thru-Hole

**Hi Reliability: -55° to +125°C**  
**TRISTATE, 1 MHz to 35 MHz**

*MF Electronics oscillators are not compliant with MIL-PRF-55310*

### GUARANTEED CAPTURE RANGE/ABSOLUTE PULL RANGE

Guaranteed Capture Range (GCR) and Absolute Pull Range (APR) are terms often used interchangeably. MF's Guaranteed Capture Range (GCR) is defined as the minimum guaranteed frequency deviation or "pull" (in ppm) around the nominal frequency, with all effects of temperature, variations in  $V_{DD}$  and load taken into account. This amount of absolute frequency deviation is available under all operating conditions for modulation or capturing other signals. No additional frequency capture allowances are necessary.

### FEATURES

- 168 hour Class B burn-in and extensive environmental testing for best performance in rugged field environments
- Crystal angle controlled to  $\pm 1$  minute for excellent temperature stability from -55 to +125°C
- Each unit is ATE-tested to guarantee full compliance with all electrical specifications
- Guaranteed Capture Range of  $\pm 50$  ppm
- Excellent incremental and best-straight-line linearity
- Start-up time is less than 10ms
- Over-control voltage up to 7V allows for 20% control voltage overshoot

### TYPICAL APPLICATIONS

- Aircraft and aerospace
- Transportation equipment
- Phase locked loops and data acquisition projects that may be exposed to the most severe environmental conditions, including:
  - xDSL customer premise equipment
  - Cable modems
  - ATM/SONET/SDH

MODEL	Control Voltage (Volts)	Frequency Deviation (ppm)	Guaranteed Capture Range (ppm)	Control Voltage at Center Frequency	Center Frequency Stability (ppm)
6306	0 to 5.0	$\pm 50$ min	$\pm 50$	2.5V	$\pm 50$ typ, $\pm 75$ max

### DESCRIPTION

M6306	$\pm 50$ ppm, min. deviation when using 0 to 5.0V control-voltage and 2.5v center with $\pm 75$ ppm stability
-------	---

### CONNECTIONS

Full Size	
Pin 1.	Not used
Pin 2.	Control Voltage, $V_C$
Pin 5.	Tristate
Pin 7.	Ground & Case
Pin 8.	Output
Pin 9.	Not used
Pin14.	+5V, $V_{DD}$

## Description

MF Electronics now offers VCXOs manufactured to Hi-Rel standards, for applications that are subjected to the most stringent environmental conditions. These VCXOs guarantee  $\pm 50$  ppm capture over -55° to +125°C. These thru-hole VCXOs generate a 5 volt HCMOS/TTL frequency output which is controlled ("pulled") by an input voltage. These VCXOs offer tristate operation, facilitating diagnostic ATE testing, or user's choice of clock speed under software control.

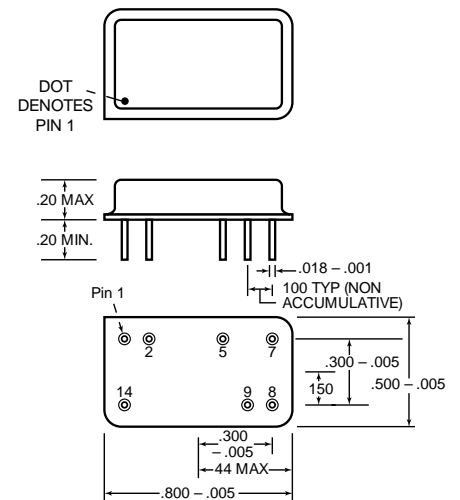

"M-1" Package





VOLTAGE CONTROLLED  
CRYSTAL OSCILLATORS  
HCMOS/TTL 5V

**Thru-Hole**

**Hi Reliability: -55° to +125°C**  
**TRISTATE, 1 MHz to 35 MHz**

FULL SIZE D.I.L.  
M package  
M6306

**ELECTRICAL SPECIFICATIONS**

**Frequency Range** 1 MHz to 35 MHz

**Frequency Stability** Includes calibration at 25°C, operating temperature, change of input voltage, change of load, shock and vibration.

	MIN	TYP	MAX	UNITS
<b>Input Voltage, V<sub>DD</sub></b>	4.5	5.0	5.5	volts
<b>Input Current</b>				
1 KHz to 10 MHz		8	14	mA
10.1 to 25 MHz		15	20	mA
25.1 to 50 MHz		20	30	mA
50.1 to 75 MHz		25	35	mA
75.1 to 125 MHz		30	40	mA
<b>Output Levels</b>				
"0" Level, sinking 16 mA			0.4	volts
"1" Level, sourcing 8 mA	V <sub>DD</sub> -4			volts
<b>Rise and Fall Times</b>				
CMOS, 15 pf, 20 to 80% (<60 MHz)		3.0	4	ns
CMOS, 30 pf, 20 to 80% (<60 MHz)		4.0	5	ns
CMOS, 50 pf, 20 to 80% (<60 MHz)		6.0	8	ns
CMOS, 15 pf, 20 to 80% (>60 MHz)		2.0	2.5	ns
CMOS, 30 pf, 20 to 80% (>60 MHz)		3.0	4.5	ns
<b>Symmetry</b>				
CMOS, @ 50% V <sub>DD</sub>		48/52	45/55	percent
<b>Aging</b>				
First year		3		ppm
After first year		1		ppm/yr
<b>Control Voltage</b>	0		7.0	volts
<b>Modulation Bandwidth</b>	15			KHz
<b>Jitter</b>				
From positive edge to positive edge		40	80	ps pk-pk
		10	15	ps RMS

**ENVIRONMENTAL SPECIFICATIONS**

**Temperature**

Operating -55° to +125°C  
Storage -55° to +125°C

**Shock** – 1000 Gs, 0.35 ms, 1/2 sine wave, 3 shocks in each plane

**Vibration** – 10-2000 Hz of .06" d.a. or 20 Gs, whichever is less

**Humidity** – Resistant to 85° R.H. at 85°C

**MECHANICAL SPECIFICATIONS**

**Gross Leak** – Each unit checked in 125°C fluorocarbon

**Case** – Stainless Steel

**Marking** – MF part number, date code, serial number and description  
Marking will withstand MIL-STD 202, Method 215

**Optional Marking** – Customer part number if required

**Leads** – Kovar, nickel plated, gold flash

**Shock** – MIL-STD 883, Method 2002, Test Condition B

**Vibration** – MIL-STD 883, Method 2007, Test Condition A

**TRISTATE FUNCTION**

Pin 5	Pin 8
Floating or 4.0V min.	Clock Output
0.4V max.	Output is tristated

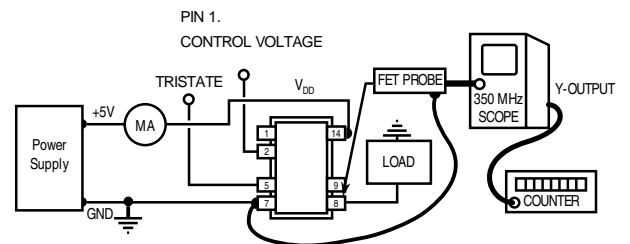

To adapt Fet probe to receptacle  
use Tektronix Part #103-0164-00

To connect output to scope use  
use Tektronix Part #131-0258-00 (receptacle)

**TEST CIRCUIT**





VOLTAGE CONTROLLED  
CRYSTAL OSCILLATORS  
HCMOS/TTL 5V

**Thru-Hole**

**Hi Reliability: -55° to +125°C**  
**TRISTATE, 1 MHz to 35 MHz**

FULL SIZE D.I.L  
M package  
M6306

**TABLE 1**

Each unit undergoes the following:

1. Stabilization Bake MIL-STD-883 Method 1008, Cond. B
2. Temperature Cycling MIL-STD-883 Method 1010, Cond. B
3. Centrifuge MIL-STD-883 Method 2001, Cond. A
4. Burn-in MIL-STD-883 Method 1015, Cond. B  
(125°C for 168 hours with bias)
5. Fine Leak MIL-STD-883 Method 1014, Cond. A1
6. Gross Leak MIL-STD-883 Method 1014, Cond. C
7. Electrical Test at 25°C and temperature extremes, as follows:

- |  |                       |
|--|-----------------------|
| A. Frequency at specified control voltages | H. Duty Cycle (FL)    |
| B. Current                                 | I. Frequency at 5.5V  |
| C. Rise Time (NL)                          | J. Frequency at 4.5V  |
| D. Fall Time (NL)                          | K. "Zero" logic level |
| E. Rise Time (FL)                          | L. "One" logic level  |
| F. Fall Time (FL)                          | M. Pullability        |
| G. Duty Cycle (NL)                         | N. Pull Linearity     |

Test data on each unit is available for additional cost

**TABLE 2 — RELIABILITY TEST PROCEDURE AND CONDITIONS FOR QUARTZ CRYSTAL OSCILLATORS**

**I. Group A**

- Electrical Characteristics at -55°, 25° and 125°C
- Frequency @ 4.5, 5.0 and 5.5 volts (for 5 volts units)
- Symmetry (Duty Cycle)
- Input current
- Zero/One levels
- Rise/Fall times
- Physical Dimensions
- Length/width
- Height
- Package finish (Corrosion, discoloration, etc.)
- Marking placement/legibility

**II. Group B – Life Test**

1000 hrs at 125°C with bias and load

**III. Group C – All units have passed Group A testing**

**A. Subgroup 1 – 8 pcs.**

Standard	Condition	Description	End point measurement
MIL-STD-883	METHOD 2002 COND. B	Mechanical shock 1500 g's, 5ms 5 drops, 6 axis	Frequency Output waveform
MIL-STD-883	METHOD 2007 COND. A	Vibration, var. freq. 20 g's, .06" disp., 20- 20,000-20 Hz	Frequency Output waveform
MIL-STD-883	METHOD 2003	Solderability	Visual 95% coverage
<b>B. Subgroup 2 - 4 pcs (One-half of Subgroup 1)</b>			
MIL-STD-883	METHOD 1011 COND. B	Thermal Shock Liq. to liq. -55 to 125°C, 15 cycles	Frequency Output waveform
MIL-STD-202	METHOD 105 COND. B.	Altitude, 3.44 inch Hg, 12 hrs	Frequency Output waveform
MIL-STD-883	METHOD 1004	Moisture resist. with 5V applied 25-65°C, 90 to 100% RH, 10 cycles	Frequency Output waveform
MIL-STD-202	METHOD 210 COND. A.	Resistance to Solder Heat Immersion @350°C 3.5 sec	Frequency Output waveform

**C. Subgroup 3 - 4 pcs. (One half of Subgroup 1)**

Standard	Condition	Description	End point measurement
	Storage Temp. No. Oper.	24 hrs. @ -55°C 24 hrs. @ 125°C	Frequency Output waveform
MIL-STD-883	METHOD 1009 COND. A	Salt Atmosphere 24 hrs. @ 35°C .5-3.0% Solution	Frequency Output waveform Visual
MIL-STD-883	METHOD 1014 COND. B	Fine Leak	Qs <5 x 10 <sup>-8</sup>
MIL-STD-883	METHOD 1014 COND. C	Gross Leak	Visual in 125°C Detector fluid

**PROCESSING FLOW CHART**

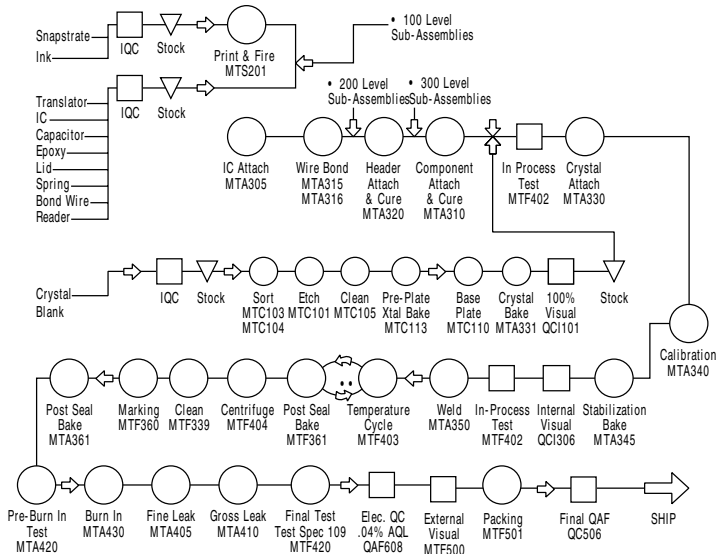

**NOTE:** • Indicates where Sub-Contracted Assemblies and Sub-Assemblies enter the Manufacturing line.  
All Sub-Contracted Assemblies and Sub-Assemblies are inspected to QCI307 and stored in stock until needed.  
•• Indicates Post Seal Bake and Temperature Cycle Processes may be performed in reverse order.



