

M5500 Series
Crystal Oscillators HCMOS 5V Thru-Hole
High Reliability 1 Hz to 125 MHz



Extended Temperature Hi-Rel Product Specification **XO**

Features

- Hermetically sealed half size or full size DIL package
- Crystal angle controlled to +/- 1 minute for excellent temperature stability
- 168 hour Class B burn-in and extensive environmental testing for best performance in rugged field environments
- Start-up time less than 10 ms, typical
- Serialized test data available

Typical Applications

Thru-hole PCB projects requiring high reliability HCMOS clock waveforms

Description

These high reliability oscillators provide HCMOS clock waveforms for applications subjected to the most stringent environmental conditions. They are through-hole mechanically robust oscillators. The "M-2" package has 14 pins which provides greater holdability onto the pc board. Each oscillator is burned-in at 125°C for 168 hours, temperature cycled and centrifuged and fully tested in accordance with Table 1. Reliability tests are performed per Table 2. The calculated MTBF is 1.4×10^6 hours at 125°C.

Full Size		Half Size		Operating Temperature	Frequency Stability
Model	Package	Model	Package		
M5500, M5516	M-2			-55 to +125°C	+/-75 ppm
M5515	M-2			0 to 70°C	+/-50 ppm
M5622	M	H5622	H	-55 to +85°C	+/-50 ppm
M5623	M	H5623	H	-55 to +125°C	+/-75 ppm

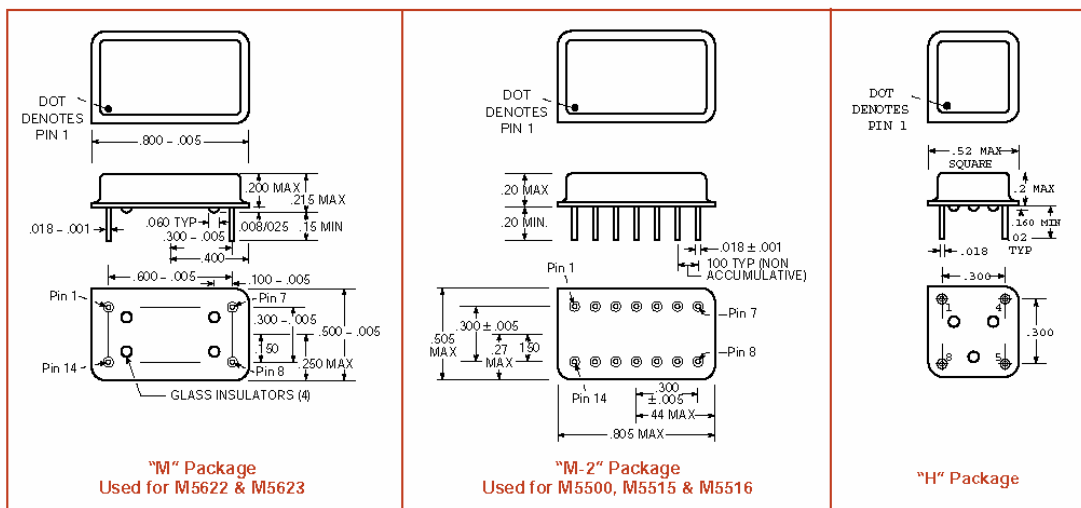

M5500 Series
Crystal Oscillators HCMOS 5V Thru-Hole
High Reliability 1 Hz to 125 MHz



ELECTRICAL SPECIFICATIONS

Frequency Range

M5500, M5515, M5516, M5622, M5623- 1 Hz to 125 MHz
H5622, H5623-1KHz to 125 MHz

Frequency Stability

Includes calibration at 25°C, operating temperature, change of input voltage, change of load, shock and vibration.

	MIN	TYP	MAX	UNITS
Input Voltage,	4.5	5.0	5.5	volts
Input Current				
Frequency at 1 KHz or above		30	55	mA
Frequency below 1 KHz		35	60	mA
Frequency Accuracy	See Preceding Table			
Waveform Symmetry				
Measured at 1.5V	40/60		60/40	percent
Rise and Fall Times				
Below 10 MHz				
0.8 to 2.4volts		5	15	ns
10 MHz and above,				
0.8 to 2.4 volts		2	5	ns
"Zero" Level,				
Sinking 16 mA			0.5	volts
"One" Level				
Sourcing 400 microAmps	4.5			volts
Sourcing to 10 TTL loads	2.5			volts
Frequency Change				
From +5.5 to +5.0V		+/-5	+/-10	ppm
From +4.5 to +5.0V		+/-5	+/-10	ppm
Aging				
First year		3		ppm
After first year		1		ppm/yr

ENVIRONMENTAL SPECIFICATIONS

Shock- MIL-STD 883, Method 2002, Test Condition B (1500 peak g, 0.5 ms duration, ½ sine wave, 5 shocks in 6 planes)

Vibration- MIL-STD 883, Method 2007, Test Condition A (20-2000 Hz of .06" d.a. or 20 Gs, whichever is less)

Humidity- Resistant to 85° R.H. at 85°C

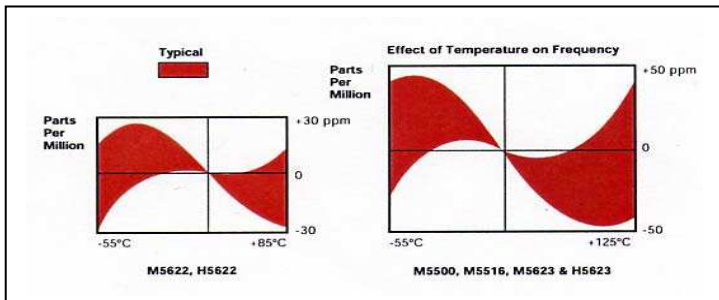

Pin	M5500	M5515, M5516	M5622, M5623
1.	Case	N.C	Case & Electrical Ground
2.	N.C.	N.C.	Pins 2 thru 6 are not present
3.	N.C.	N.C.	
4.	N.C.	N.C.	
5.	N.C.	N.C.	
6.	N.C.	N.C.	
7.	Electrical Ground	Case & Electrical Ground	Case & Electrical Ground
8.	Output	Output	Output
9.	N.C.	N.C.	Pins 9 thru 13 are not present
10.	N.C.	N.C.	
11.	N.C.	N.C.	
12.	N.C.	N.C.	
13.	N.C.	N.C.	
14.	+5V, V _{DD}	+5V, V _{DD}	+5V, V _{DD}

CONNECTIONS

	Half Size
Pin 1.	Not Used
Pin 4.	Ground and Case
Pin 5.	Output
Pin 8.	+5V, V _{DD}

PROCESSING FLOW CHART

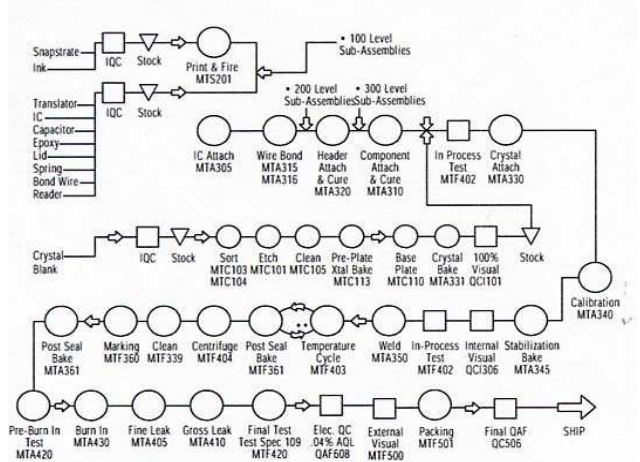

NOTE: • Indicates where Sub-Contracted Assemblies and Sub-Assemblies enter the Manufacturing Line.
All Sub-Contracted Assemblies and Sub-Assemblies are inspected to QC1307 and stored in stock until needed.
•• Indicates Post Seal Bake and Temperature Cycle Processes may be performed in reverse order.

M5500 Series
Crystal Oscillators HCMOS 5V Thru-Hole
High Reliability 1 Hz to 125 MHz

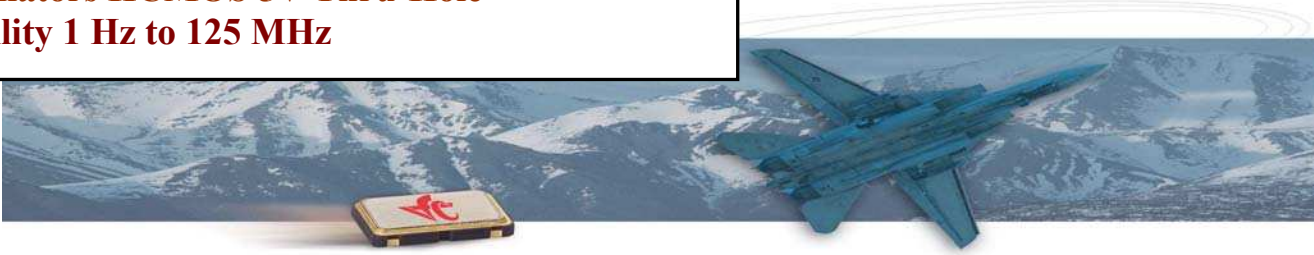

MECHANICAL DESCRIPTION

- Case-** Stainless Steel
Marking- Valpey part number, date code, serial number and description. Markings will withstand MIL-STD 202, Method 215.
Optional Marking- Customer part number if required
Leads- Kovar, nickel plated, gold flash
Shock- MIL-STD 883, Method 2002, Test Condition B
Vibration- MIL-STD 883, Method 2007, Test Condition A

TABLE 1

Each unit undergoes the following:

- | | |
|--|---|
| 1. Stabilization Bake | MIL-STD-883 Method 1008, Cond. B |
| 2. Temperature Cycling | MIL-STD-883 Method 1010, Cond. B |
| 3. Centrifuge | MIL-STD-883 Method 2001, Cond. A |
| 4. Burn-in | MIL-STD-1015 1015, Cond. B
(125°C for 168 hours with bias) |
| 5. Fine Leak | MIL-STD-883 Method 1014, Cond. A1 |
| 6. Gross Leak | MIL-STD-883, Method 1014, Cond. C |
| 7. Electrical Test at 25°C and temperature extremes, as follows: | |

- | | |
|--------------------|-----------------------|
| A. Frequency* | F. Duty Cycle (FL) |
| B. Current | G. Frequency at 5.5V |
| C. Rise Time (FL) | H. Frequency at 4.5V |
| D. Fall Time (FL) | I. "Zero" logic level |
| E. Duty Cycle (NL) | J. "One" logic level |

*Within 75 ppm from -55 to +125°C (M5500, M5516 and M5623)
 Within 50 ppm from 0 to +70°C (M5515)
 Within 50 ppm from -55 to +85°C (M5622)

HOW TO ORDER

For Part Number, put package type before mode number, and add frequency in MHz, for example:

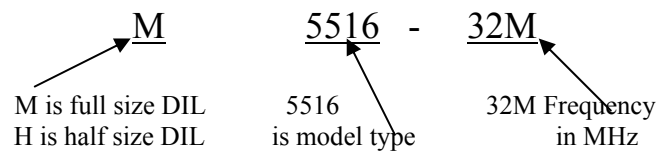

TABLE 2- RELIABILITY TEST PROCEDURE AND CONDITIONS FOR QUARTZ CRYSTAL OSCILLATORS

Standard	Condition	Description	End point measurement
I. Group A			
Electrical Characteristics at -55°, (0° for '5515), 25° and 125° (70° for M5515 and 85° for M5622)			
Frequency @ 4.5, 5.0 and 5.5 volts (for 5 volts units)			
Symmetry (Duty Cycle)			
Input current			
Zero/One levels			
Rise/Fall times			
Physical Dimensions			
Length/width			
Height			
Package finish (Corrosion, discoloration, etc.)			
Marking placement/legibility			
II. Group B- Life Test			
1000 hrs at 125°C with bias and load			
III. Group C- All units have passed Group A testing			
A. Subgroup 1-8 pcs.			
MIL-STD-883	Method 2002 COND.B	Mechanical Shock 1500 g's, 5ms 5 drops, 6 axis	Frequency Output Waveform
MIL-STD-883	Method 2007 COND. A.	Vibration, var. freq. 20 g's, .06" disp., 20- 20, 000-20 Hz	Frequency Output waveform
MIL-STD-883	Method 2003	Solderability	Visual 95% coverage
B. Subgroup 2-4 pcs (One-half of Subgroup 1)			
MIL-STD-883	Method 1011 COND. B	Thermal Shock Liq. To liq. 15 cycles	Frequency Output waveform
MIL-STD-202	Method 105 COND. B	Altitude, 3.44 inch Hg. 12 hrs	Frequency Output waveform
MIL-STD-883	Method 1004	Moisture resist. With 5V applied 25-65°C, 90 to 100% RH, 10 cycles	Frequency Output waveform
MIL-STD-202	Method 210 COND.A	Resistance to Solder Heat Immersion @350°C 3.5 sec	Frequency Output waveform
C.Subgroups 3-4 pcs. (One half of Subgroup 1)			
Standard	Condition	Description	End point measurement
	Storage Temp.	24 hrs. @ -55°C	Frequency
	No. Oper	24 hrs. @ 125°C	Output waveform
MIL-STD-883	Method 1009 COND. A	Salt Atmosphere 24 hrs. @ 35°C	Frequency Output waveform
MIL-STD-883	Method 1014 COND. B	.5-3.0% Solution Fine Leak	Visual Qs <5 X10 ⁸
MIL-STD-883	Method 1014 COND. C	Gross Leak	Visual in 125°C Detector fluid