

Helping Customers Innovate, Improve & Grow



Features

- Ultra-High Stability
- Excellent Temperature Stability
- SC-Cut Crystal
- Previous Model: C4700, 4895, OC-050, CO-330
- Frequency Range: 4 MHz to 15 MHz

Applications

- CDMA2000 and UMTS Base Stations
- Test and Measurement Equipment

Performance Specifications

Frequency Stabilities ¹					
Parameter	Min	Typ	Max	Units	Condition
vs. operating temperature range (referenced to +25°C)	-0.4		+0.4	ppb	-0... +70°C
	-0.2		+0.2	ppb	-0... +70°C
	-0.4		+0.4	ppb	-20... +70°C
Warm-up Time			5	minutes	to ± 10 ppb of final frequency (1 hour) @25°C
Initial Tolerance	-50		+50	ppb	at time of shipment, nominal EFC VS ± 5% Load ± 5% after 72 hours of operation after 72 hours of operation
vs. supply voltage change	-0.1		+0.1	ppb	
vs. load change	-0.1		+0.1	ppb	
vs. aging / day	-0.5		+0.5	ppb	
vs. aging / 1 year	-20		+20	ppb	
vs. aging / year (following years)	-10		+10	ppb	
Supply Voltage (Vs)					
Supply voltage (Standard)	11.4	12.0	12.6	VDC	
Supply voltage (Option)	4.75	5.0	5.25	VDC	
Power consumption @+12V			12	Watts	during warm-up
			4	Watts	steady state @ +25°C
Power consumption @+5V			12	Watts	during warm-up
			4	Watts	steady state @ +25°C

Performance Specifications

Frequency Stabilities ¹					
Parameter	Min	Typ	Max	Units	Condition
RF Output					
Signal [Standard]	HCMOS				
Load		15		pF	
Signal Level (Vol)			0.5	VDC	with 15pF load, 12 V supply
Signal Level (Vol)			0.3	VDC	with 15pF load, 5 V supply
Signal Level (Voh)	4.5			VDC	with 15pF load, 12 V supply
Signal Level (Voh)	2.8			VDC	with 15pF load, 5 V supply
Duty cycle	45		55	%	(Voh-Vol)/2
Signal [Option]	Sinewave				
Load		50		ohm	
Output Power	+5.0	+7.0	+9.0	dBm	50 Ohm load
Harmonics			-30	dBc	50 Ohm load
Sub-Harmonics			-40	dBc	50 Ohm load
Frequency Tuning (EFC)					
Tuning Range	±0.25	±0.5	±0.75	ppm	
Linearity			20	%	
Control Voltage Range	0	+2.5	+5.0	VDC	
Tuning Slope	Positive				
Additional Parameters					
Phase Noise @ 10 MHz			-90	dBc/Hz	1 Hz
			-120	dBc/Hz	10 Hz
			-135	dBc/Hz	100 Hz
			-140	dBc/Hz	1 KHz
			-140	dBc/Hz	>10 KHz
Weight			140	g	
Processing & Packing	Handling & processing note				
Absolute Maximum Ratings					
Supply Voltage			28	VDC	
Output Load			50 25	pF ohm	with HCMOS signal with Sinewave signal
Operable temperature range	-55		+85	°C	
Storage temperature range	-55		+125	°C	

Outline Drawing / Enclosure

Dimensions in mm

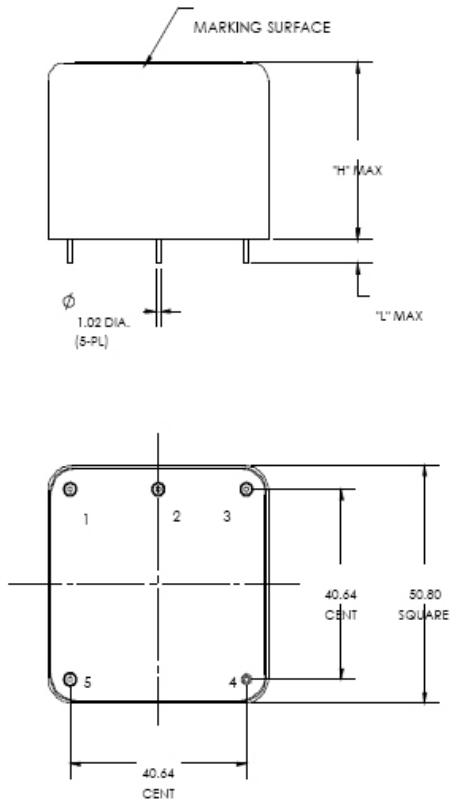

Type A		
Code	Height "H"	Pin Length "L"
0	25.40	6.35
1	19.00	6.35
2	38.07	6.35
3	17.27	6.35

Pin Connections	
1	Electronic Frequency Control (EFC)
2	Reference Voltage Output
3	RF Output
4	Ground (Case)
5	Supply Voltage Input (Vs)

Ordering Information

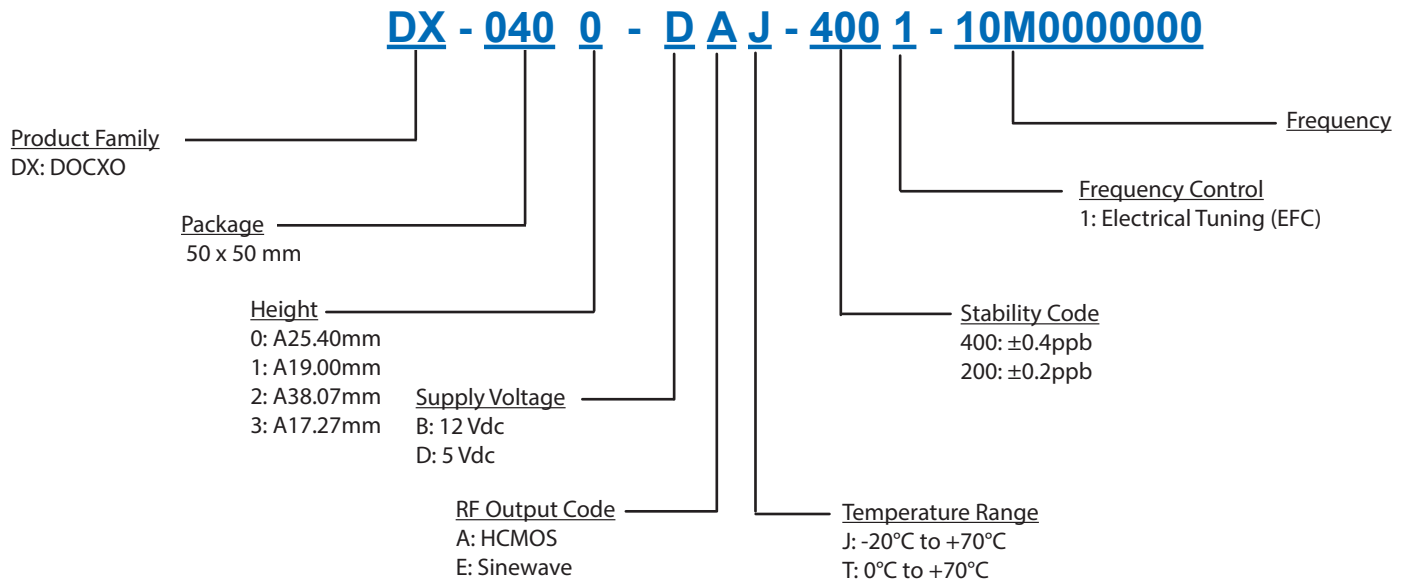

Notes:

1. Contact factory for improved stabilities or additional product options. Not all options and codes are available at all frequencies.
2. Unless other stated all values are valid after warm-up time and refer to typical conditions for supply voltage, frequency control voltage, load, temperature (25°C).
3. Phase noise degrades with increasing output frequency.
4. Subject to technical modification.
5. Contact factory for availability.

For Additional Information, Please Contact

USA:

Vectron International
267 Lowell Road, Suite 102
Hudson, NH 03051
Tel: 1.888.328.7661
Fax: 1.888.329.8328

Europe:

Vectron International
Landstrasse, D-74924
Neckarbischofsheim, Germany
Tel: +49 (0) 3328.4784.17
Fax: +49 (0) 3328.4784.30

Asia:

Vectron International
68 Yin Cheng Road(C), 22nd Floor
One LuJiaZui
Pudong, Shanghai 200120, China
Tel: +86 21 6194 6886
Fax: +86 21 6194 6699

Disclaimer

Vectron International reserves the right to make changes to the product(s) and or information contained herein without notice. No liability is assumed as a result of their use or application. No rights under any patent accompany the sale of any such product(s) or information.

Rev: 2-13-14 jar